

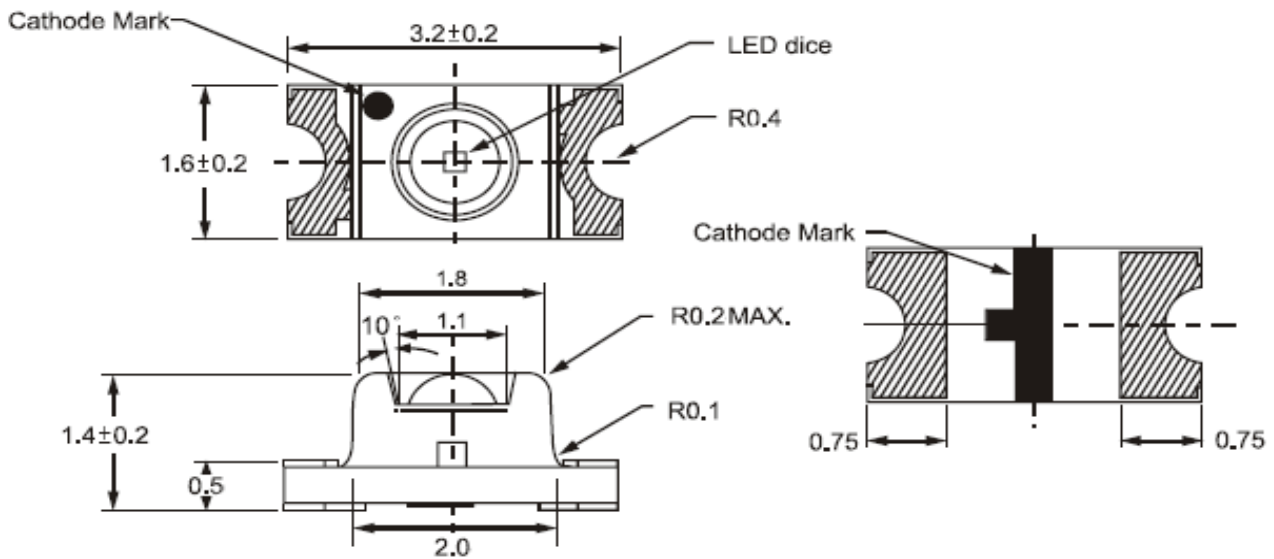

Applications

- Interior automotive lighting
- Optical indicators
- Communication Products
- Backlighting
- Toys

Technical Drawing



Recommended Soldering Pattern

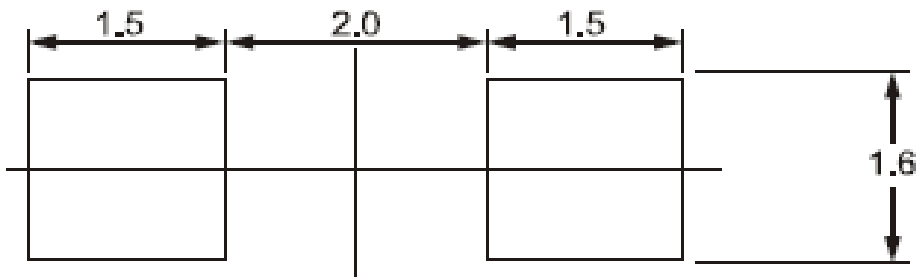

Notes :

All dimensions in mm tolerance is $\pm 0.1\text{mm}$ unless otherwise noted.

SMT Chip LED Yellow	
Part No.:	M11G5011
Customer:	

DRW:	Dong	CHKD	Chang	MATL:	Chui	DATE	05.12.2009
APPD:	Ping			FINISH	Hui	Sheet	1 from 9



Absolute Maximum Ratings

Ta=25°C

Item	Symbol	AlGaInP	Unit
Power Dissipation	P _D	---	mW
DC Forward Current	I _F	30	mA
Pulsed Forward Current	I _{FP} *	100	mA
Reverse Voltage	V _R	5	V
Operating Temperature	T _{OP}	-25 to 80	°C
Storage Temperature	T _{ST}	-40 to 85	°C

* 0.1 msec pulse, 10% duty cycle

Electrical / Optical Characteristics

I_F=20mA Ta=25°C

Emitting Color	Yellow		
Material	AlGaInP		
Forward Voltage	typ.	2.1	V _F
	max.	2.6	V _F
Wavelength typ.	λ _D	587	nm
	λ _P	590	nm
	Δλ	---	nm
Color Temperature	min.	---	K
	max.	---	K
Luminous Intensity *	min.	63	mcd
	typ.	130	mcd
Reverse Current	max.	---	μA
Viewing Angle	2θ _{1/2}	60	

* Per NIST standards

SMT Chip LED
Yellow

Part No.: **M11G5011**

Customer:

DRW:	Dong	CHKD	Chang	MATL:	Chui	DATE	05.12.2009
APPD:	Ping			FINISH	Hui	Sheet	2 from 9



Directive Characteristics

**SMT Chip LED
Yellow**

Part No.: **M11G5011**

Customer:

DRW:	Dong	CHKD	Chang	MATL:	Chui	DATE	05.12.2009
APPD:	Ping			FINISH	Hui	Sheet	3 from 9

Copyright by EDCON-COMPONENTS



Curvs

SMT Chip LED Yellow	
Part No.:	M11G5011
Customer:	

DRW:	Dong	CHKD	Chang	MATL:	Chui	DATE	05.12.2009
APPD:	Ping			FINISH	Hui	Sheet	4 from 9



Solder Condition

Lead Free Solder



SMT Chip LED Yellow	
Part No.:	M11G5011
Customer:	

DRW:	Dong	CHKD	Chang	MATL:	Chui	DATE	05.12.2009
APPD:	Ping			FINISH	Hui	Sheet	5 from 9



Packing Specifications



Reel Specifications



**SMT Chip LED
Yellow**

Part No.: **M11G5011**

Customer:

DRW:	Dong	CHKD	Chang	MATL:	Chui	DATE	05.12.2009
APPD:	Ping			FINISH	Hui	Sheet	6 from 9



Handling Precautions

Compare to epoxy encapsulant that is hard and brittle, silicone is softer and flexible. Although its characteristic significantly reduces thermal stress, it is more susceptible to damage by external mechanical force. As a result, special handling precautions need to be observed during assembly using silicone encapsulated LED products. Failure to comply might lead to damage and premature failure of the LED.

1. Handle the component along the side surfaces by using forceps or appropriate tools



2. Do not directly touch or handle the silicone lens surface. It may damage the internal circuitry.



3. Do not stack together assembled PCBs containing exposed LEDs. Outside impact may scratch the silicone lens or damage the internal circuitry.



SMT Chip LED Yellow	
Part No.:	M11G5011
Customer:	

DRW:	Dong	CHKD	Chang	MATL:	Chui	DATE	05.12.2009
APPD:	Ping			FINISH	Hui	Sheet	7 from 9



4. The outer diameter of the TOP LED pickup nozzle should not exceed the size of the LED to prevent air leaks. The inner diameter of the nozzle should be as large as possible.
5. A pliable material is suggested for the nozzle tip to avoid scratching or damaging the LED surface during pickup.
6. The dimensions of the component must be accurately programmed in the pick-and-place machine to insure precise pickup and avoid damage during production.



SMT Chip LED Yellow	
Part No.:	M11G5011
Customer:	

DRW:	Dong	CHKD	Chang	MATL:	Chui	DATE	05.12.2009
APPD:	Ping			FINISH	Hui	Sheet	8 from 9



Color table curve



SMT Chip LED Yellow	
Part No.:	M11G5011
Customer:	

DRW:	Dong	CHKD	Chang	MATL:	Chui	DATE	05.12.2009
APPD:	Ping			FINISH	Hui	Sheet	9 from 9

Copyright by EDCON-COMPONENTS