

EDCON-COMPONENTS

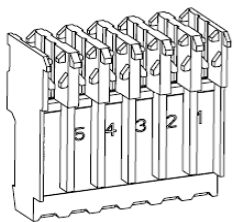

Specifications

Voltage Rating: 250VAC /DC
Current Rating 2,0AC / DC
Operating Temperature . -40°C ~ +130°C
Contact Resistance 20m Ω Max.
Withstanding Voltage 1000V AC/minute
Insulation Resistance 1000M Ω Min.

Material Insulator: Nylon 66 UL94V-0 White
 Nylon 66 UL94V-2 Red R/LF
 Nylon 66 UL94V-2 Natural LF
Material Pin Brass
Pin Plating: Brass; Tin Plated

Drawing (dimensions all into mm)

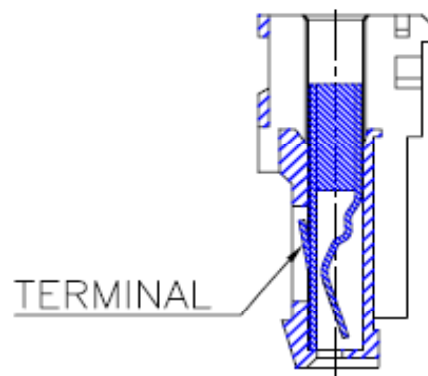
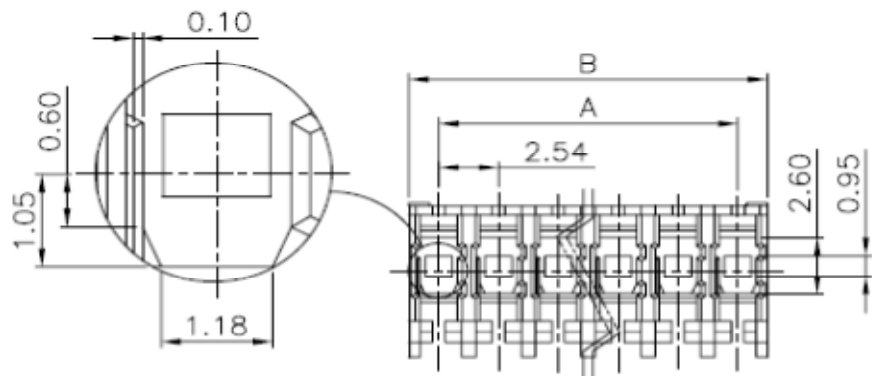
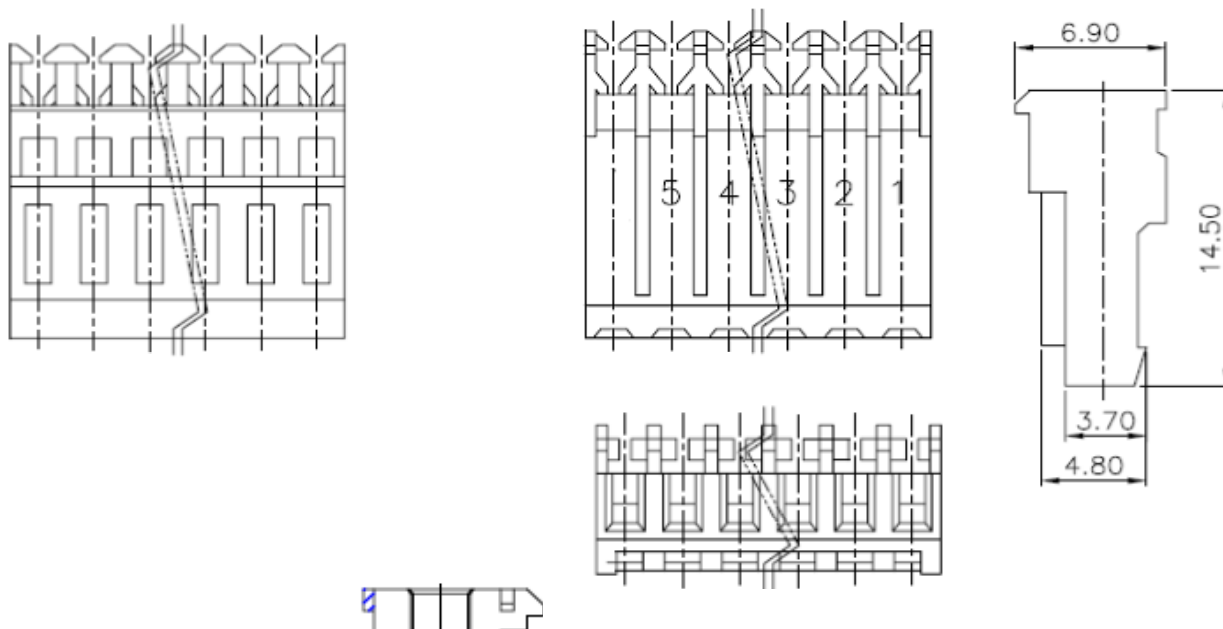

Wire to Board Pitch 2,54mm	
Alternative to Serie MASCONN	
Part No.:	T68N014-
Customer:	

DRW:	Jason	CHKD	Wilson	MATL:	Wilson	TOLERANCE	Mason	DATE	18.06.2020
APPD:	Schumi			FINISH	Jamy		Sheet No.		1 from 4

EDCON-COMPONENTS

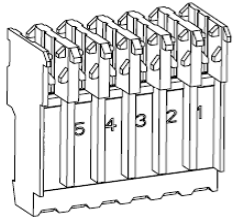

Dimension Informations about Wafer

Pos.	Dimension (mm)					
	A	B	C	D	E	F
02	2,54	5,08				
03	5,08	7,62				
04	7,62	10,16				
05	10,16	12,70				
06	12,70	15,24				
07	15,24	17,78				
08	17,78	20,32				
09	20,32	22,86				
10	22,86	25,40				
11	25,40	27,94				
12	27,94	30,48				
13	30,48	33,02				
14	33,02	35,56				
15	35,56	38,10				
16	38,10	40,64				
17	40,64	43,18				
18	43,18	45,72				
19	45,72	48,26				
20	48,26	50,80				
21	50,80	53,34				
22	53,34	55,88				
23	55,88	58,42				
24	58,42	60,96				
25	60,96	63,50				

Pos.	Dimension (mm)					
	A	B	C	D	E	F
26	63,50	66,04				
27	66,04	68,58				
28	68,58	71,12				

Wire to Board Pitch 2,54mm	
Alternative to Serie MASCONN	
Part No.:	T68N014-
Customer:	

DRW:	Jason	CHKD	Wilson	MATL:	Wilson	TOLERANCE	Mason	DATE	18.06.2020
APPD:	Schumi			FINISH	Jamy		Sheet No.		2 from 4

EDCON-COMPONENTS

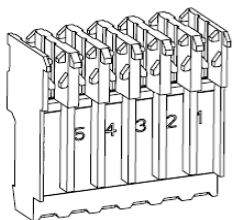

Ordering Informations

Serie	Positions	Body Color	Special	C- Plating	ROHS	Packing				
T68N014-	02	22	V2	TN	R	BU				

Look Table	28 =AWG28	V2= LF UL94 V2	TN= Tin Plated	R= ROHS Conform	BU= Bulk (Standard)
	26 =AWG26	VR= ROHS /LF UL94 V2	GF= Gold Flash	N= NON ROHS Conform	
	24 =AWG24	V0= LF UL94 V0			
	22 =AWG22				

**Wire to Board Pitch 2,54mm
Alternative to Serie MASCONN**

Part No.: **T68N014-**

Customer:

DRW:	Jason	CHKD	Wilson	MATL:	Wilson	TOLERANCE	Mason	DATE	18.06.2020
APPD:	Schumi			FINISH	Jamy		Sheet No.		3 from 4

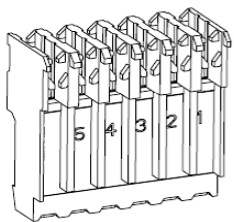

Soldering Profile

Lead Free Curve

Classification Reflow Profile (JEDEC J-STD-020C)

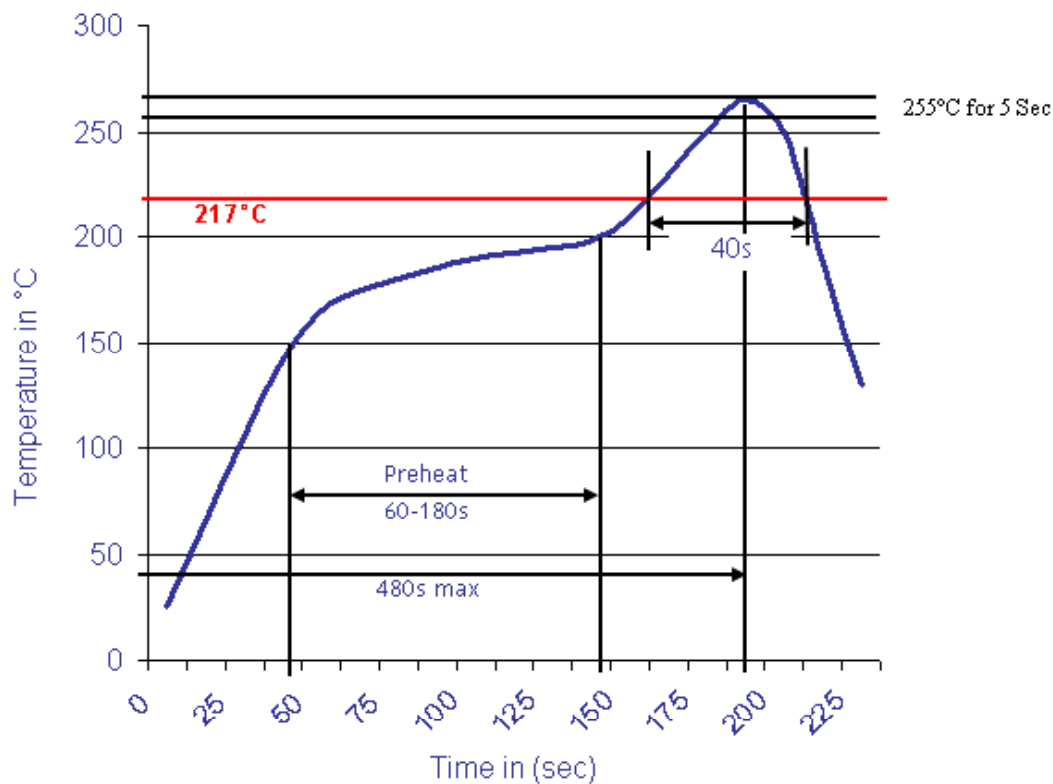

Wire to Board Pitch 2,54mm Alternative to Serie MASCONN
Part No.: T68N014-
Customer:

DRW:	Jason	CHKD	Wilson	MATL:	Wilson	TOLERANCE	Mason	DATE	18.06.2020
APPD:	Schumi			FINISH	Jamy		Sheet No.	4 from 4	