

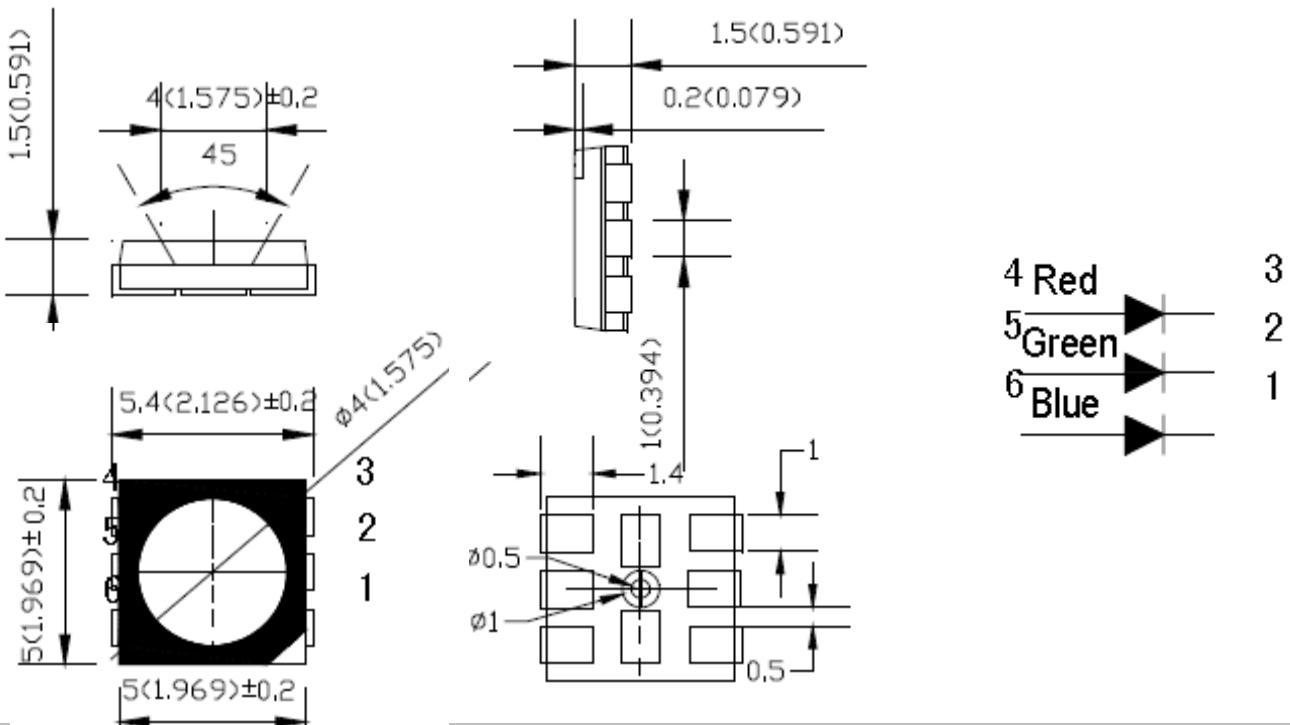

Applications

- Interior automotive lighting(dashboard backlight etc...)
- Optical indicators
- High Tech Lightning
- Security Parts
- Automotive Products

Package Dimensions (Tol. +/- 0,10mm)



Recommend Soldering Pad Dimensions (Tol. +/- 0,10mm)

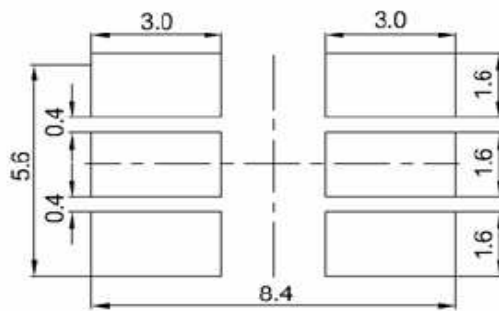

Notes:					CHIP LED FOR REVERSE PCB MOUNTING		
All dimensions in mm tolerance is ±0.1mm unless otherwise noted.					Part.No.	M11A6005	
					Customer		
DRW:	Harry	CHKD	Dustin	Tolerance	Tolerance:	Date:	08.07.2011
APPD:	Jason	MATL	Wilson	John	MASON	Sheet No.	1 from 6



Absolute Maximum Ratings (Ta = 25°C)

Item-Disription	Symbol	Value	Unit
DC Forward Current	PD	60	mW
Pulse Forward Current	IFP	100	mA
Forward Current:	IFP	25	mA
Reverse Voltage:	VR	5	V
Electrostatic Discharge:	ESD	2000	V
Operating Voltage	Topr	.-30 ~ +80	°C
Storage Temperature	Tstg	.-40 ~ +100	°C
Lead Soldering Temp.	Tsol	260°C/5Sec.	---

Typical Electrical & Optical Characteristics (IF=20mA and Ta = 25°C)

Item	Symbol	Condition	Min.	Typ.	Max.	Unit
Luminious Intensity: Red	Iv	IF=20mA		600		mcd
Luminious Intensity: Green	Iv	IF=20mA		1300		mcd
Luminious Intensity: Blue	Iv	IF=20mA		400		mcd
Viewing Angle:	20 1/2	IF=20mA		130		Deg.
Domi. Wavelength: Red	λ_d	IF=20mA	620		630	nm
Domi. Wavelength: Green	λ_d	IF=20mA	520		525	nm
Domi. Wavelength: Blue	λ_d	IF=20mA	465		470	nm
DC Forward Voltage: Red	Vf	IF=20mA		2,20		V
DC Forward Voltage:Green	Vf	IF=20mA		3,20		V
DC Forward Voltage: Blue	Vf	IF=20mA		3,20		V
DC Reverse Voltage:	Ir	Vr=5V			5	μ A

Notes:

1. Tolerance of measurement of luminous intensity	: $\pm 10\%$
2. Tolerance of measurement of chromatic coordinates	: $\pm 1\text{nm}$
3. Tolerance of measurement of forward voltage	: $\pm 0.1\text{V}$

CHIP LED LED FOR REVERSE PCB MOUNTING

					Part.No.	M11A6005	
					Customer		
DRW:	Harry	CHKD	Dustin	Tolerance	Tolerance:	Date:	08.07.2011
APPD:	Jason	MATL	Wilson	John	MASON	Sheet No.	2 from 6



Diagramm of viewing angle



Diagramm of LED

Relative Intensity vs. Forward Current



Forward Voltage V's. Forward Current

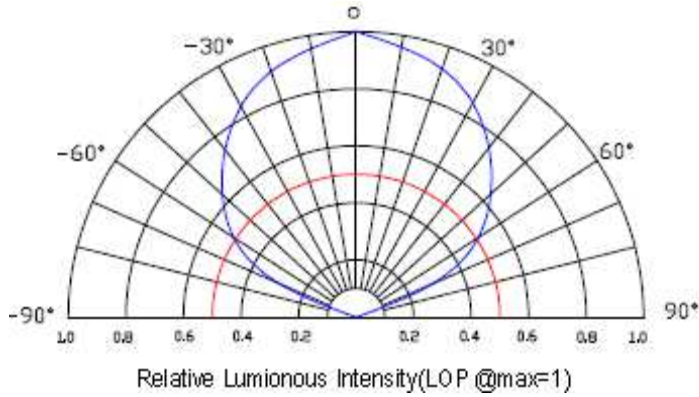
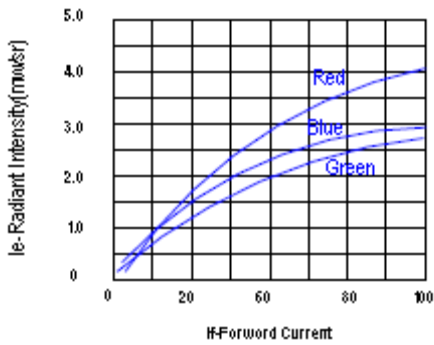
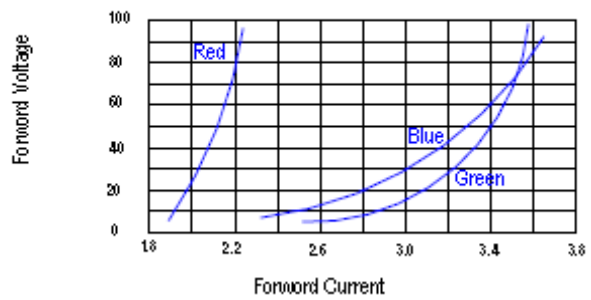

Relative Intensity V's. Ambient Temperature °C

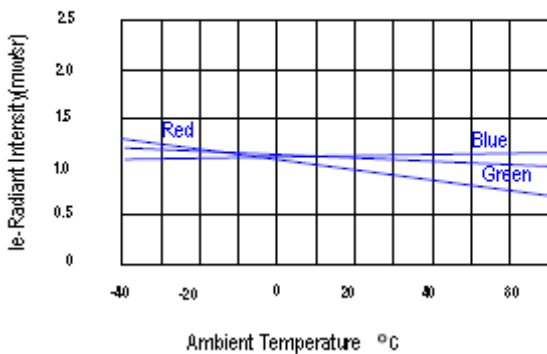

Forward Current Derating Curve

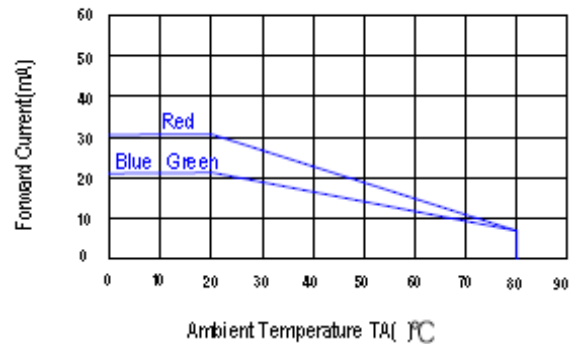

CHIP LED LED FOR REVERSE PCB MOUNTING

Part.No.	M11A6005
Customer	

DRW:	Harry	CHKD	Dustin	Tolerance	Tolerance:	Date:	08.07.2011
APPD:	Jason	MATL	Wilson	John	MASON	Sheet No.	3 from 6



Soldering condition for Lead solder

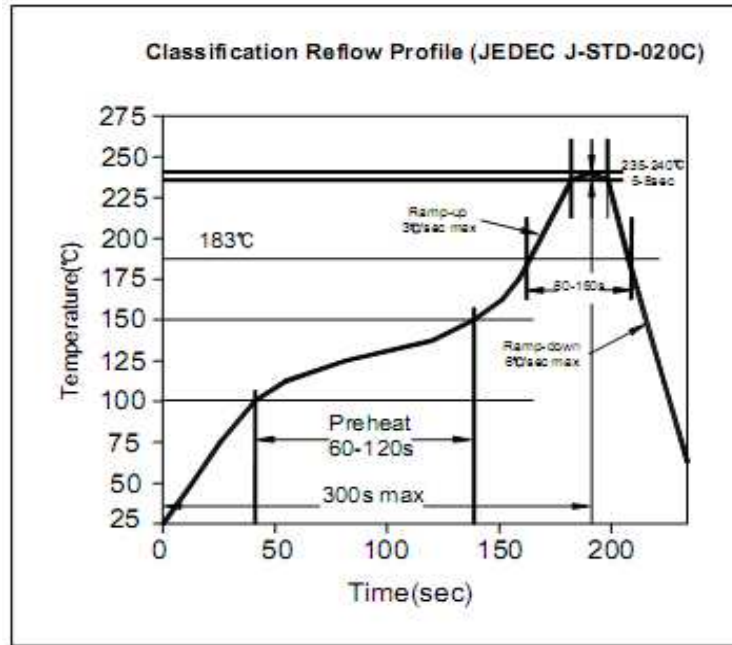

Soldering condition for Lead free solder

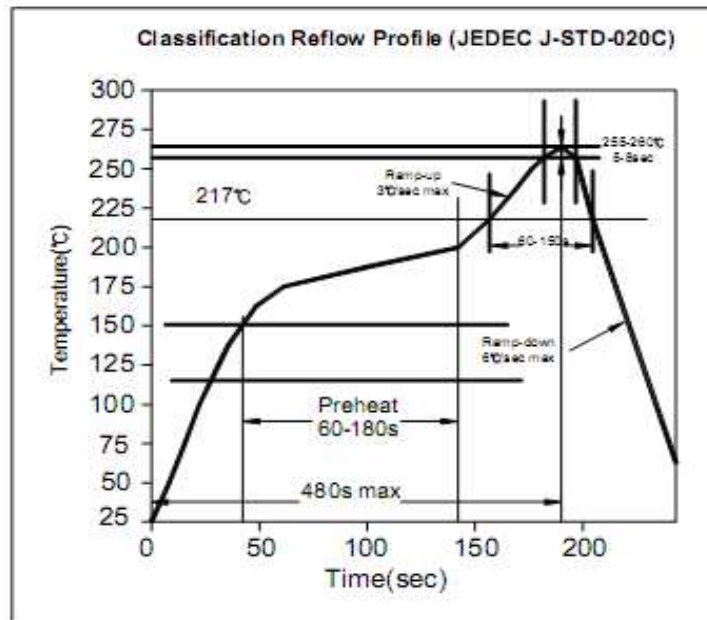

CHIP LED FOR REVERSE PCB MOUNTING

Part.No.	M11A6005
Customer	

DRW:	Harry	CHKD	Dustin	Tolerance	Tolerance:	Date:	08.07.2011
APPD:	Jason	MATL	Wilson	John	MASON	Sheet No.	4 from 6



Packing specification (Antistatic Poly Bag)

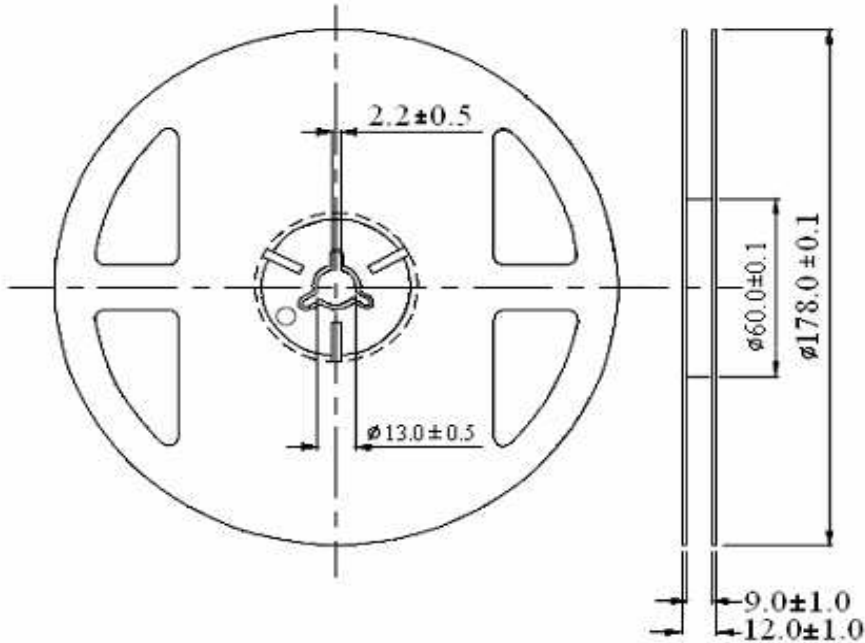

Unit: mm
Tolerance: ± 0.25mm

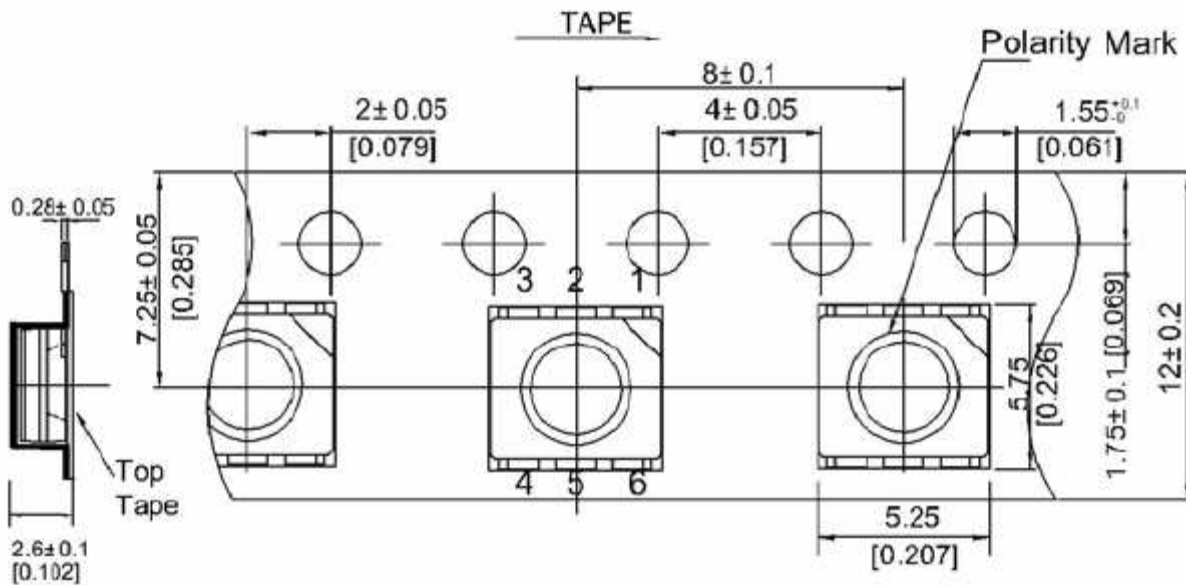

Quantity of Reel (2000PCS Normal) other Packing Specifications available	CHIP LED FOR REVERSE PCB MOUNTING	
	Part.No.	M11A6005
	Customer	

DRW:	Harry	CHKD	Dustin	Tolerance	Tolerance:	Date:	08.07.2011
APPD:	Jason	MATL	Wilson	John	MASON	Sheet No.	5 from 6



Color table curve

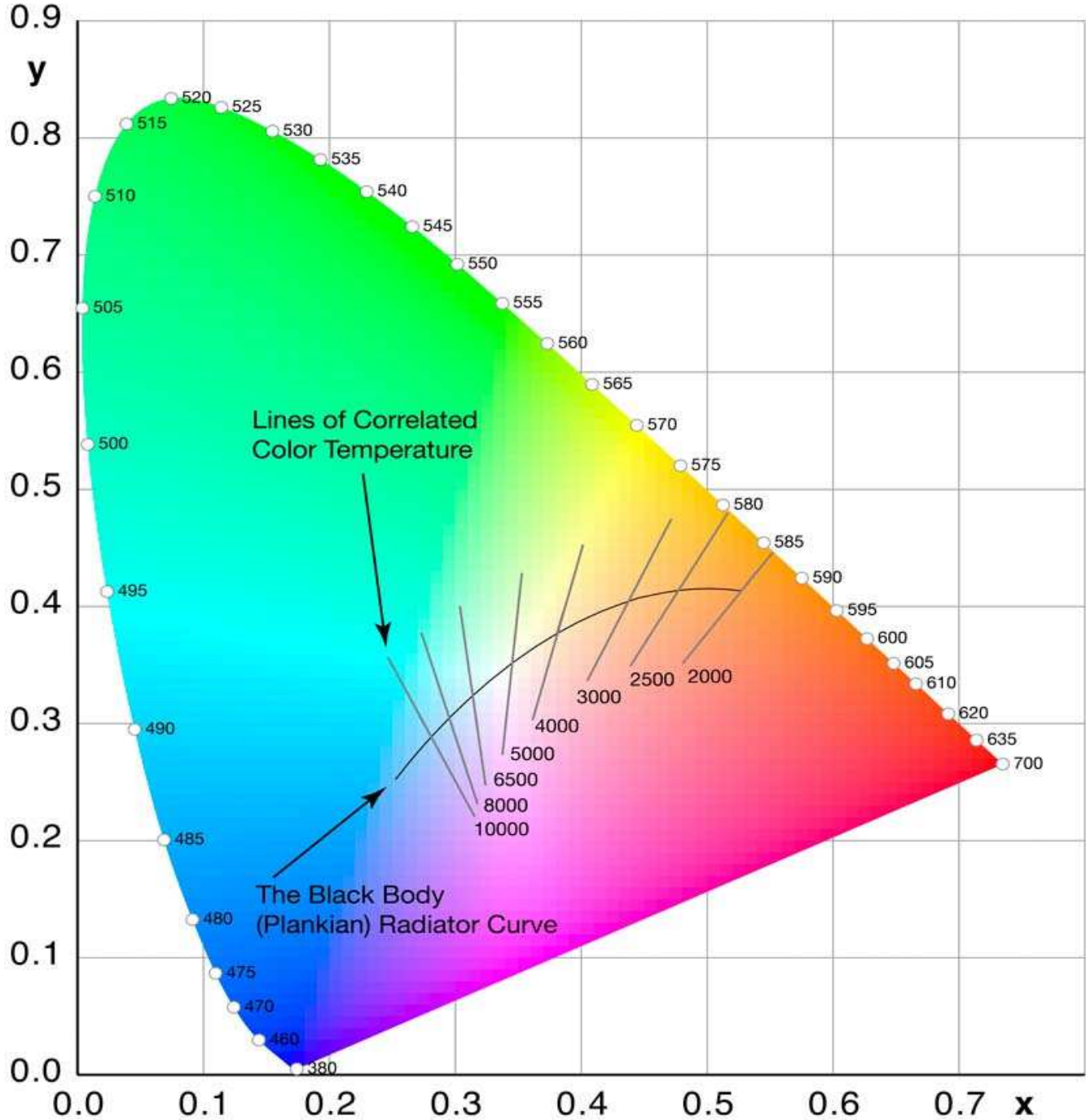

CHIP LED FOR REVERSE PCB MOUNTING

Part.No.	M11A6005
Customer	

DRW:	Harry	CHKD	Dustin	Tolerance	Tolerance:	Date:	08.07.2011
APPD:	Jason	MATL	Wilson	John	MASON	Sheet No.	6 from 6