

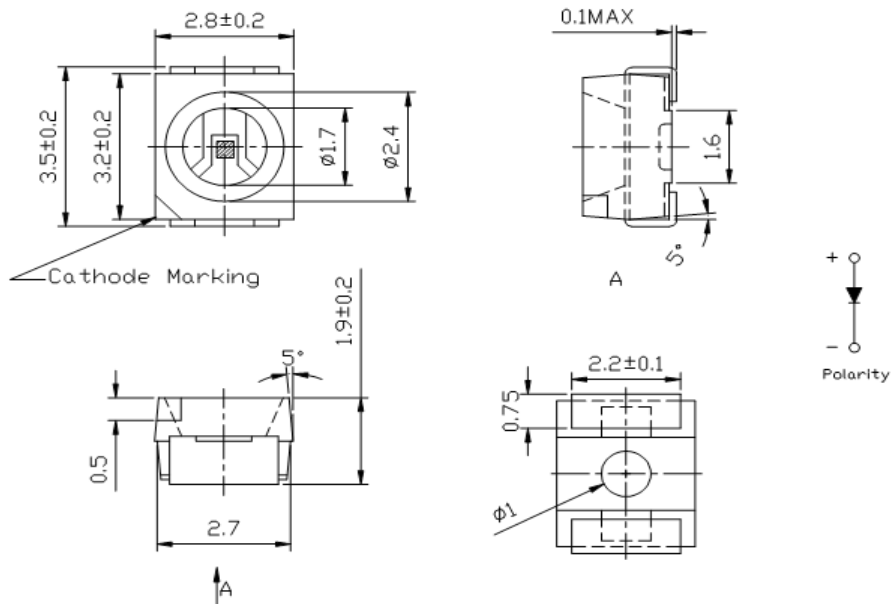

Applications

- Interior automotive lighting
- Optical indicators
- Communication Products
- Backlighting
- Toys

Technical Drawing



Recommended Soldering Pattern

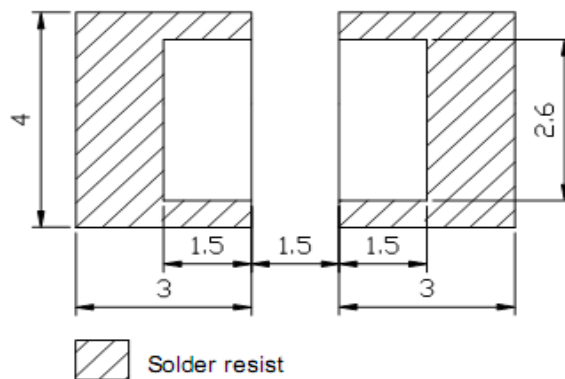

Notes :

All dimensions in mm tolerance is $\pm 0.1 \text{ mm}$ unless otherwise noted.

PLCC2 White	
Part No.:	M11A1328
Customer:	

DRW:	Dong	CHKD	Chang	MATL:	Chui	DATE	04.12.2009
APPD:	Ping			FINISH	Hui	Sheet	1 from 9



Absolute Maximum Ratings

<i>Item</i>	<i>Symbol</i>	<i>---</i>	<i>Unit</i>
Power Dissipation	P _D	---	mW
DC Forward Current	I _F	---	mA
Pulsed Forward Current	I _{FP} *	---	mA
Reverse Voltage	V _R	---	V
Operating Temperature	T _{OP}	---	°C
Storage Temperature	T _{ST}	---	°C

* 0.1 msec pulse, 10% duty cycle

Electrical / Optical Characteristics

Emitting Color	White		
Material	---		
Forward Voltage	typ.	3.0	V _F
	max.	3.2	V _F
Wavelength typ.	λ _D	x = 0.38 y = 0.40	nm
	λ _P	---	nm
	Δλ	---	nm
Color Temperature	min.	4000	K
	max.	4200	K
Luminous Intensity *	min.	2100	mcd
	typ.	2300	mcd
Reverse Current	max.	---	μA
Viewing Angle	2Θ _{1/2}	120	

* Per NIST standards

PLCC2 White	
Part No.:	M11A1328
Customer:	

DRW:	Dong	CHKD	Chang	MATL:	Chui	DATE	04.12.2009
APPD:	Ping			FINISH	Hui	Sheet	2 from 9



Directive Characteristics

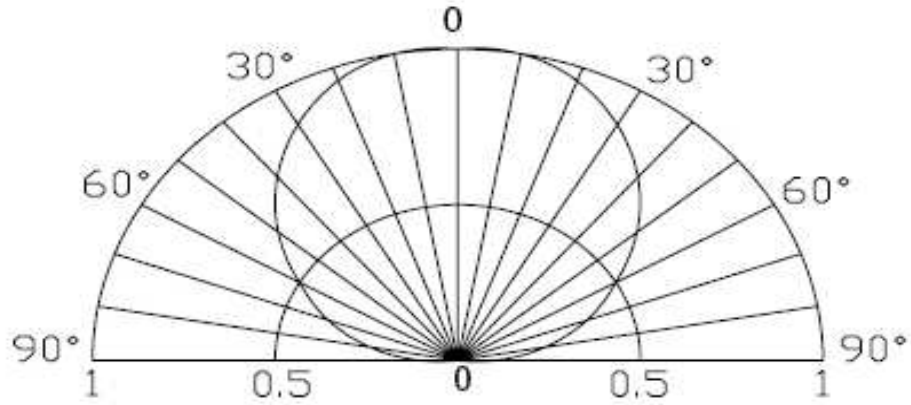

PLCC2
White

Part No.: **M11A1328**

Customer:

DRW:	Dong	CHKD	Chang	MATL:	Chui	DATE	04.12.2009
APPD:	Ping			FINISH	Hui	Sheet	3 from 9



Curve

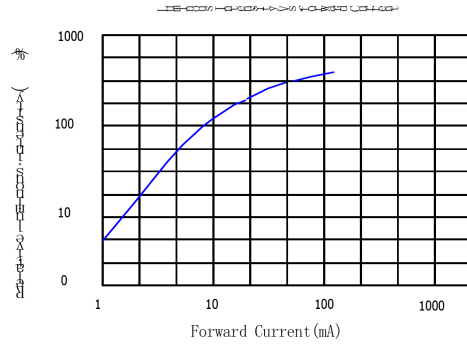
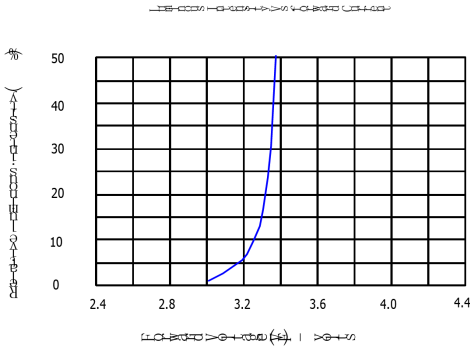

Forward Current Derating Curve

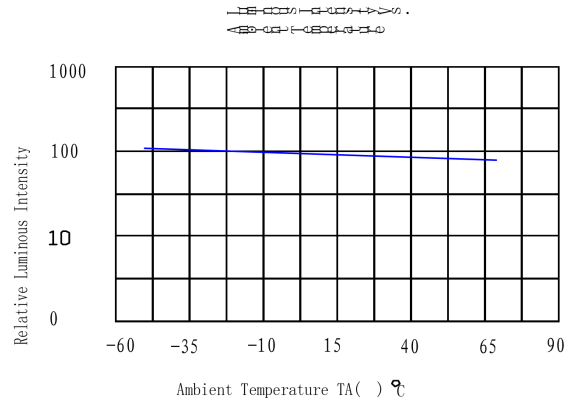
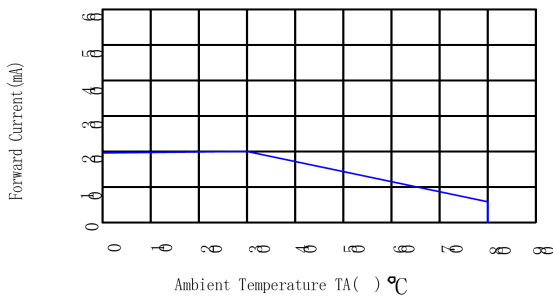

Spectral Reduance

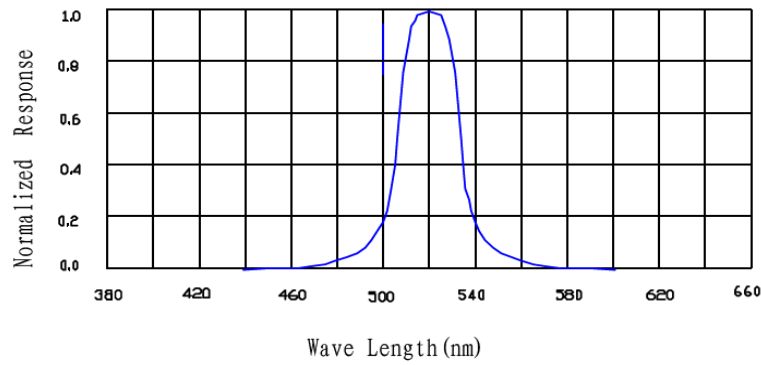

PLCC2 White	
Part No.:	M11A1328
Customer:	

DRW:	Dong	CHKD	Chang	MATL:	Chui	DATE	04.12.2009
APPD:	Ping			FINISH	Hui	Sheet	4 from 9



Solder Condition

Lead Free Solder

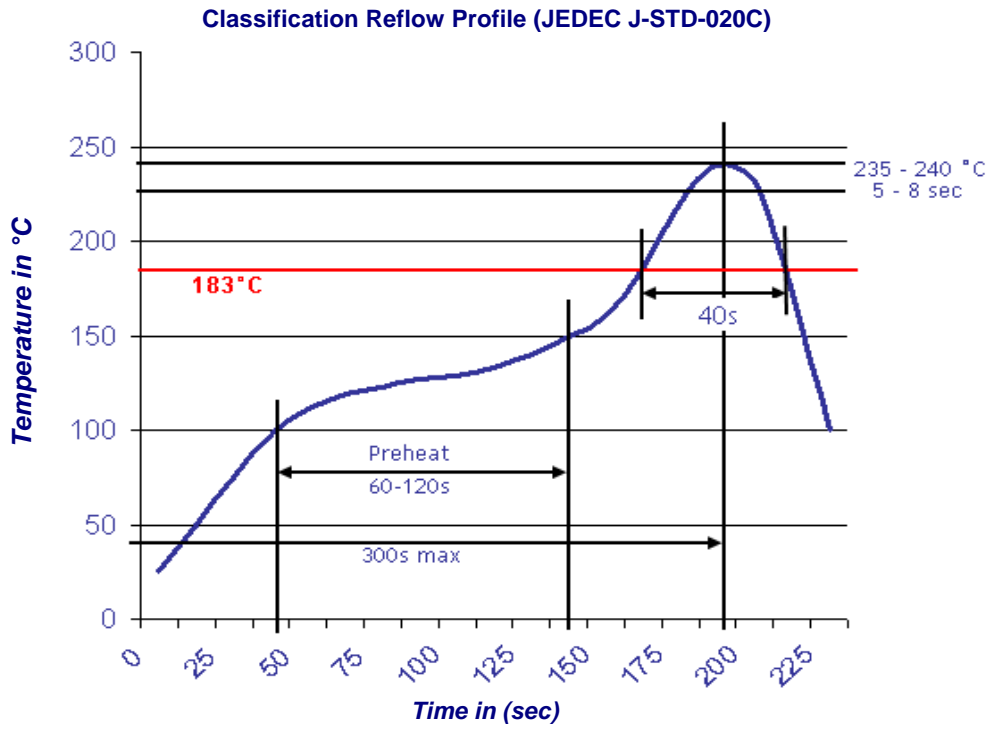

PLCC2 White	
Part No.:	M11A1328
Customer:	

DRW:	Dong	CHKD	Chang	MATL:	Chui	DATE	04.12.2009
APPD:	Ping			FINISH	Hui	Sheet	5 from 9



Packing Specifications

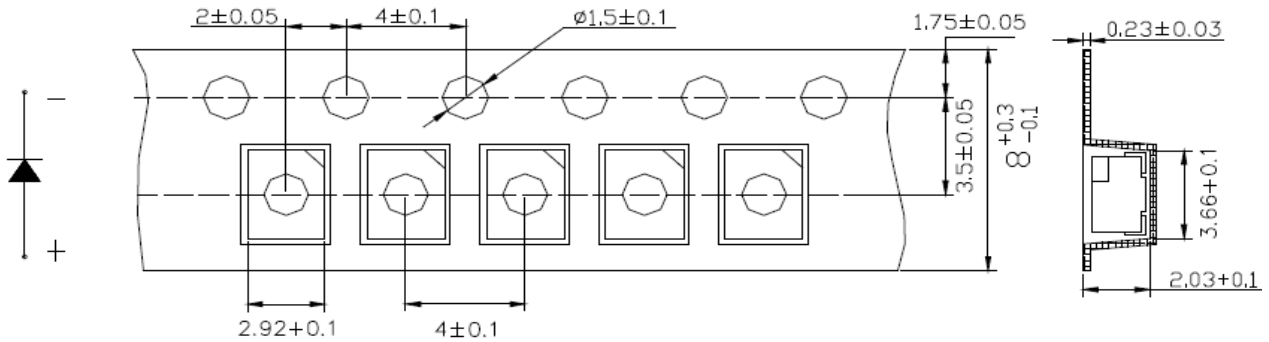

Reel Specifications

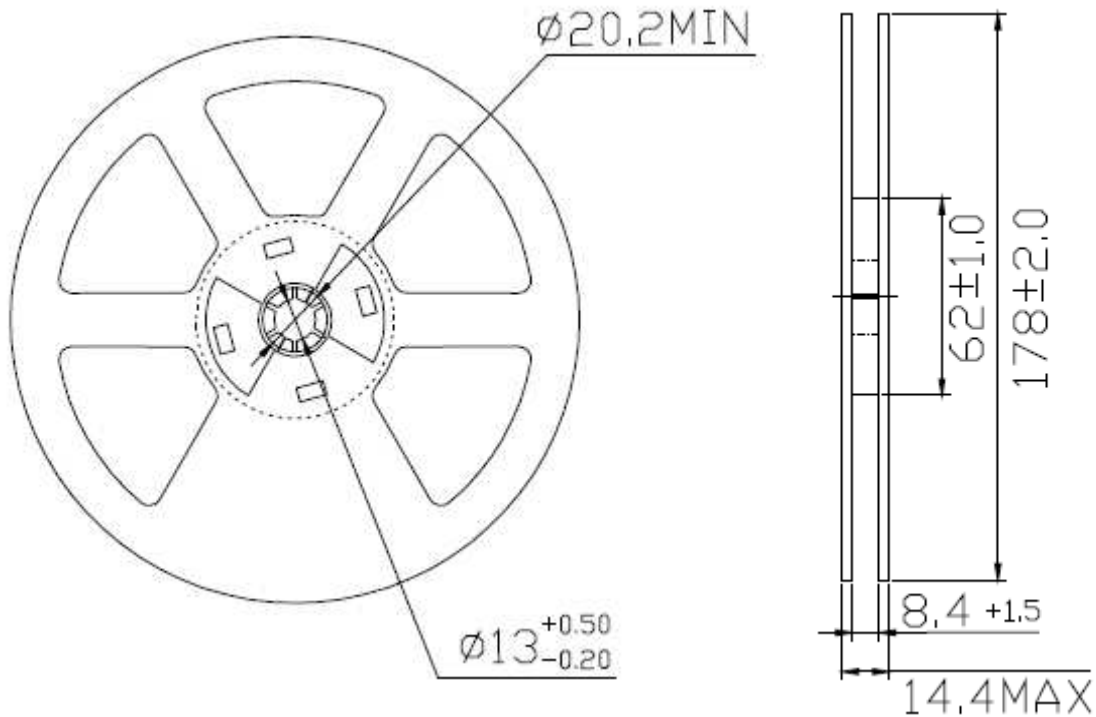

PLCC2
White

Part No.: **M11A1328**

Customer:

DRW:	Dong	CHKD	Chang	MATL:	Chui	DATE	04.12.2009
APPD:	Ping			FINISH	Hui	Sheet	6 from 9



Handling Precautions

Compare to epoxy encapsulant that is hard and brittle, silicone is softer and flexible. Although its characteristic significantly reduces thermal stress, it is more susceptible to damage by external mechanical force. As a result, special handling precautions need to be observed during assembly using silicone encapsulated LED products. Failure to comply might lead to damage and premature failure of the LED.

1. Handle the component along the side surfaces by using forceps or appropriate tools

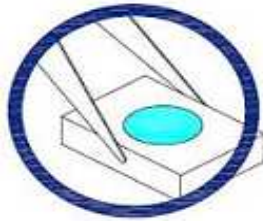

2. Do not directly touch or handle the silicone lens surface. It may damage the internal circuitry.

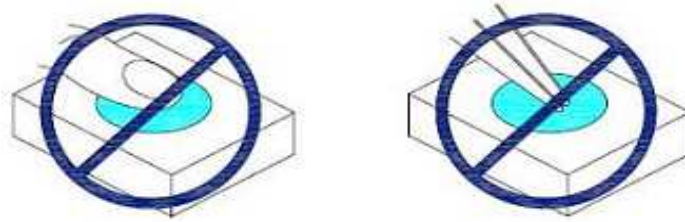

3. Do not stack together assembled PCBs containing exposed LEDs. Outside impact may scratch the silicone lens or damage the internal circuitry.



PLCC2
White

Part No.: **M11A1328**

Customer:

DRW:	Dong	CHKD	Chang	MATL:	Chui	DATE	04.12.2009
APPD:	Ping			FINISH	Hui	Sheet	7 from 9



4. The outer diameter of the TOP LED pickup nozzle should not exceed the size of the LED to prevent air leaks. The inner diameter of the nozzle should be as large as possible.
5. A pliable material is suggested for the nozzle tip to avoid scratching or damaging the LED surface during pickup.
6. The dimensions of the component must be accurately programmed in the pick-and-place machine to insure precise pickup and avoid damage during production.

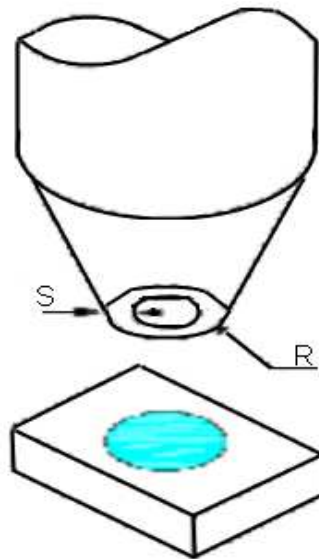

PLCC2 White	
Part No.:	M11A1328
Customer:	

DRW:	Dong	CHKD	Chang	MATL:	Chui	DATE	04.12.2009
APPD:	Ping			FINISH	Hui	Sheet	8 from 9



Color table curve

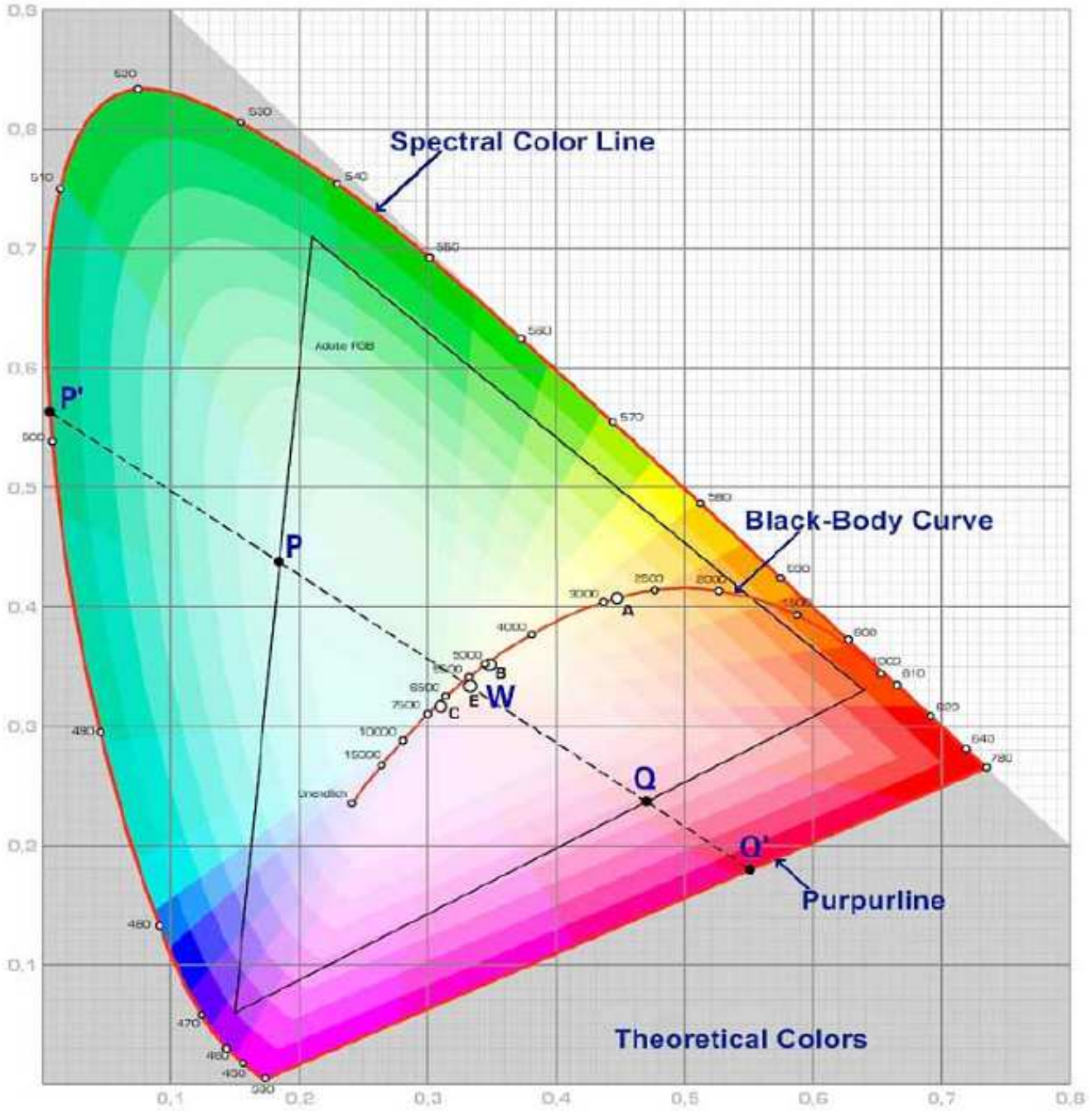

PLCC2 White	
Part No.:	M11A1328
Customer:	

DRW:	Dong	CHKD	Chang	MATL:	Chui	DATE	04.12.2009
APPD:	Ping			FINISH	Hui	Sheet	9 from 9

Copyright by EDCON-COMPONENTS