

Data Sheet

Elevated Terminal Block Closed Bottem

Pitch: 7,62 mm

Serie: A13R009

Customer Information for special Item

EDCON Customer : 0

Customer Version No. : 0

EDCON-COMPONENTS



Technical Discription

Drawing (Dimension in mm)

Electrical

	UL	IEC
Rated Voltage	300V	450V
Rated Current	20A	20A
Wire Range	AWG 26~2	0,5~2,5mm ²
Withstanding Voltage	AC 2500V/1Min.	
Torque	0,5Nm (4.4Lb-In.)	
Ambient Temperature	-40°C ~ +105°C	
Wire Strip Length	7mm	

Dimensions

Pitch (mm)	7,62mm
Poles	2P, 3P ~ 24P

Materials

Terminal Housing	PA66, UL94V-0
Screw	M3, Steel, Cr3+ Zn plated
Pin Header	Brass, Tin plated
Cage	Brass, Ni plated

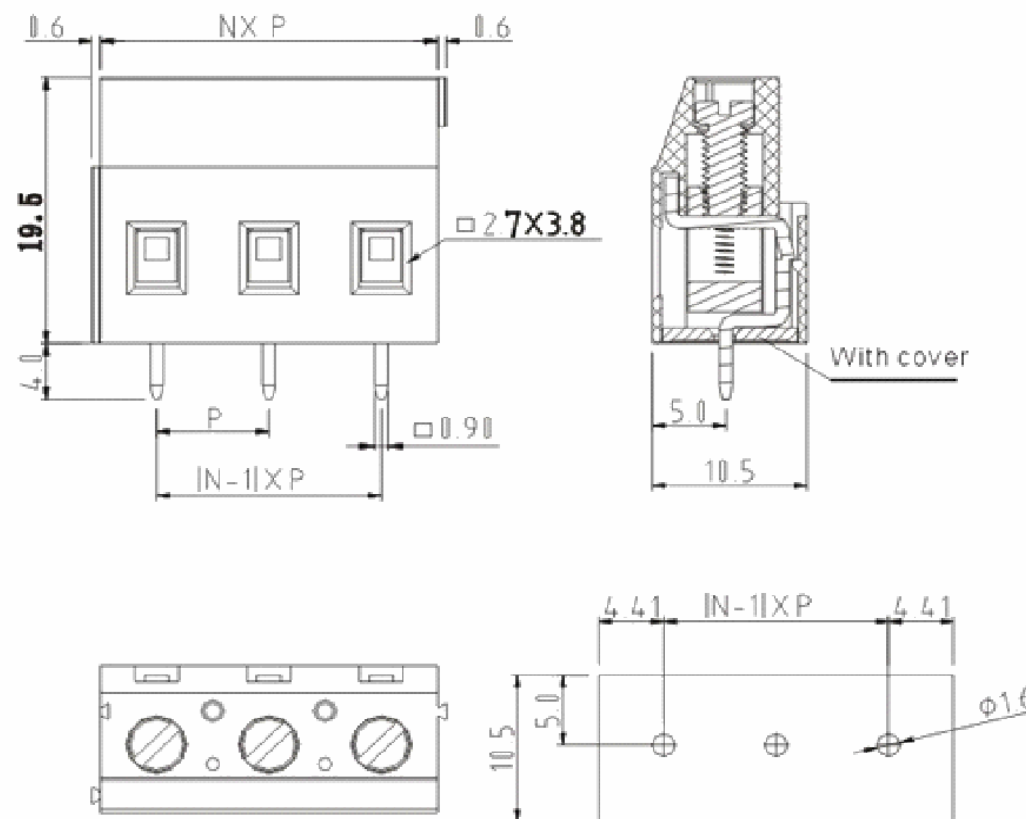

Elevated Terminal Block Closed Bottom

Part No.: **A13R009**

Customer:

DRW:	Jason	CHKD	Wilson	MATL:	Wilson	TOLERANCE	Mason	DATE	27.10.2011
APPD:	Schumi			FINISH	Jamy		Sheet No.		1 from 3

www.edcon-components.com

email: info@edcon-components.com



EDCON-COMPONENTS



Ordering Informations

Serie	No. of Pos.	Body Color	Screw	Approval Code	ROHS	Packing	EDCON Cust. No.	Customer Version		
-------	-------------	------------	-------	---------------	------	---------	-----------------	------------------	--	--

A13R009	02	PG	S	N	R	B				
----------------	-----------	-----------	----------	----------	----------	----------	--	--	--	--

Pitch 7,62	02 = Number of Pos. Standard 2 ~ 24Pos.	PG = Phoenix Green (Standard) WH = White GN = Green GY = Gray LG = Light Gray OR = Orange BL = Blue BK = Black	S = Slit Screw Type (Standard)  C = Cross Slit Screw Type (on request) 	N = NON Approval A = UL /UR Approval Please consult EDCON for available B = VDE Approval Please consult EDCON for available C = TÜV Approval Please consult EDCON for available	R = ROHS Conform N = NON ROHS Conform	B = Bulk-Ware I = Individual Package	xxxxxx = Customer Number	xxx = Customer Version ??(Printing)		
---------------	---	---	--	--	--	---	---------------------------------	--	--	--

**Elevated Terminal Block
Closed Bottem**
Part No.: **A13R009**

DRW:	Jason	CHKD	Wilson	MATL:	Wilson	TOLERANCE	Mason	DATE	27.10.2011
APPD:	Schumi			FINISH	Jamy			Sheet No.	2 from 3

Customer:



Soldering Profile Curve

Classification Reflow Profile (JEDEC J-STD-020C)

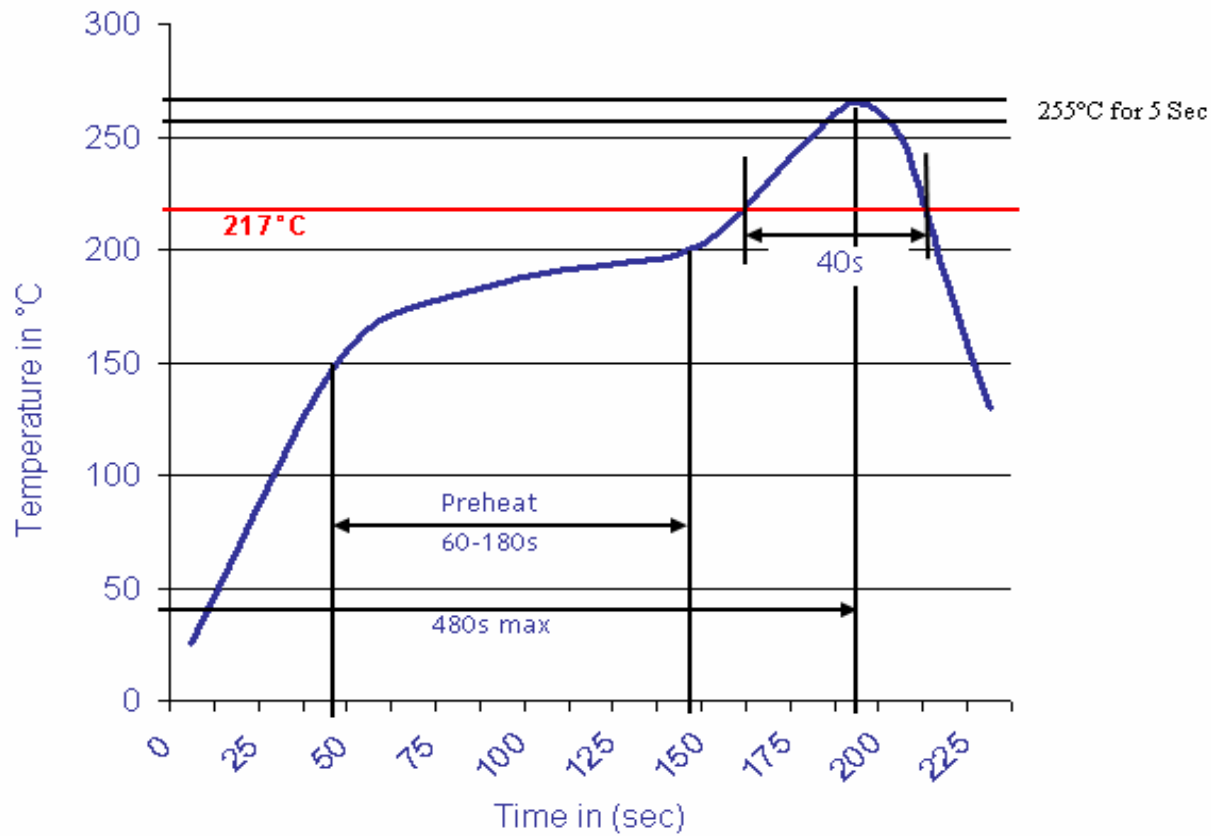

Elevated Terminal Block Closed Bottem	
Part No.:	A13R009
Customer:	

DRW:	Jason	CHKD	Wilson	MATL:	Wilson	TOLERANCE	Mason	DATE	27.10.2011
APPD:	Schumi			FINISH	Jamy		Sheet No.	3 from 3	