

Data Sheet

Elevated Terminal Block

Pitch: 7,50 mm

Serie: A13Q010

Customer Information for special Item

EDCON Customer : 0

Customer Version No. : 0

EDCON-COMPONENTS



Technical Discription

Drawing (Dimension in mm)

Electrical

Rated Voltage	250 Volt
Rated Current	18A
Wire Range	
Solid Wire	AWG 14~24
Stranged Wire	AWG 14~24
Withstanding Voltage	2,5KV
Insulation Resistance	5000MΩ / 1000V

Mechanical

Operating Temperature	. -40°C ~ +105°C
Wire Strip Length	7mm

Dimensions

Pitch (mm)	7,50
Poles	2 + 3Pos. ~ 24 Pos.

Materials

1 Terminal Housing	Thermoplastic (UL94V-0)
2 Clamp	Brass Ni, plated
3 Wire guard	Wire guard solder Pin
4 Terminal screw	Steel Zinc plating
5 Terminal Housing Cover	Thermoplastic (UL94V-0)

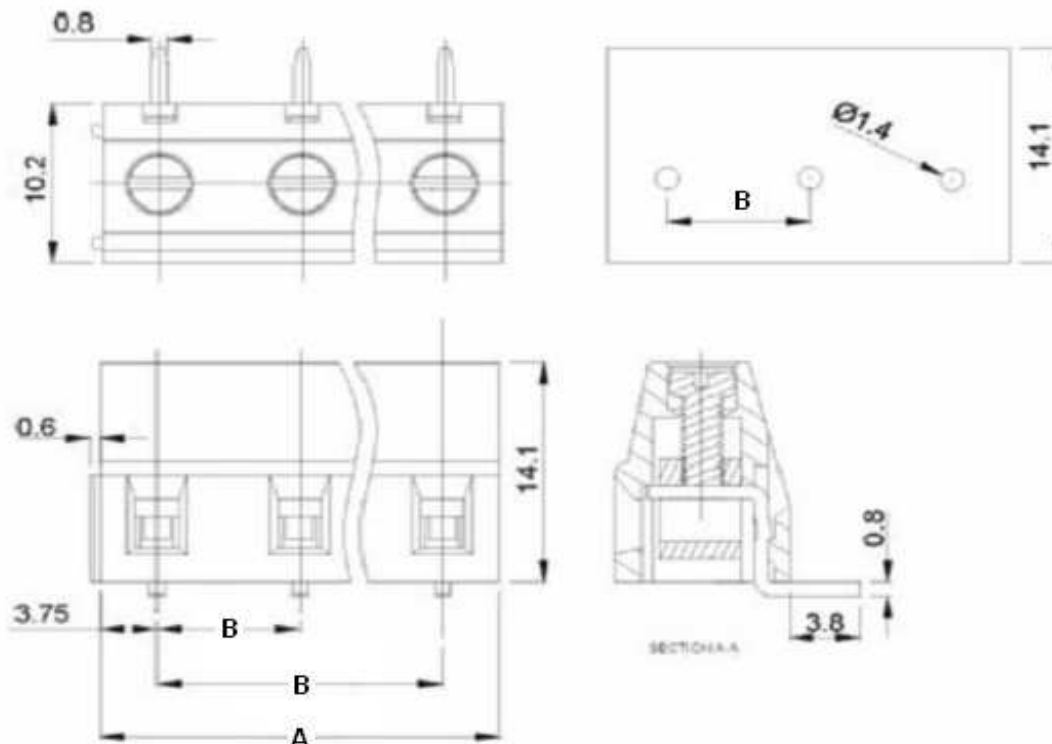

Elevated Terminal Block

Part No.: **A13Q010**

Customer:

DRW:	Jason	CHKD	Wilson	MATL:	Wilson	TOLERANCE	Mason	DATE	11.02.2011
APPD:	Schumi			FINISH	Jamy		Sheet No.		1 from 4

EDCON-COMPONENTS



Dimensions (mm)

No. of Pos.	A	Tol. A	B	Tol. B
02	15,00	± 0,15	7,50	± 0,15
03	22,50	± 0,15	15,00	± 0,15
04	30,00	± 0,15	22,50	± 0,15
05	37,50	± 0,15	30,00	± 0,15
06	45,00	± 0,15	37,50	± 0,15
07	52,50	± 0,25	45,00	± 0,25
08	60,00	± 0,25	52,50	± 0,25
09	67,50	± 0,25	60,00	± 0,25
10	75,00	± 0,25	67,50	± 0,25
11	82,50	± 0,25	75,00	± 0,25
12	90,00	± 0,25	82,50	± 0,25
13	97,50	± 0,35	90,00	± 0,35
14	105,00	± 0,35	97,50	± 0,35
15	112,50	± 0,35	105,00	± 0,35
16	120,00	± 0,35	112,50	± 0,35
17	127,50	± 0,35	120,00	± 0,35
18	135,00	± 0,35	127,50	± 0,35
19	142,50	± 0,35	135,00	± 0,35
20	150,00	± 0,40	142,50	± 0,40
21	157,50	± 0,40	150,00	± 0,40
22	165,00	± 0,40	157,50	± 0,40
23	172,50	± 0,40	165,00	± 0,40
24	180,00	± 0,40	172,50	± 0,40

Elevated Terminal Block

Part No.: **A13Q010**

Customer:

DRW:	Jason	CHKD	Wilson	MATL:	Wilson	TOLERANCE	Mason	DATE	11.02.2011
APPD:	Schumi			FINISH	Jamy		Sheet No.		2 from 4



EDCON-COMPONENTS



Ordering Informations

Serie	No. of Pos.	Body Color	No Function	Approval Code	ROHS	Packing	EDCON Cust. No.	Customer Version		
-------	-------------	------------	-------------	---------------	------	---------	-----------------	------------------	--	--

A13Q010	02	PG	A	N	R	B				
----------------	-----------	-----------	----------	----------	----------	----------	--	--	--	--

Pitch 7,50	02 = Number of Pos. Standard 2 + 3Pos- ~ 24Pos.	PG = Phoenix Green (Standard) WH = White GN = Green GY = Gray LG = Light Gray OR = Orange BL = Blue BK = Black	A = Slotted Screw Type (Standard)  B = Cross Slotted Screw Type 	N = NON Approval A = UL /UR Approval Please consult EDCON for available B = VDE Approval Please consult EDCON for available C = TÜV Approval Please consult EDCON for available	R = ROHS Conform N = NON ROHS Conform	B = Bulk-Ware I = Individual Package	xxxxxx = Customer Number	xxx = Customer Version ??(Printing)		
---------------	-----------------------------------------------------------	---------------------------------------------------------------------------------------------------------------------------------------------------------------------------------------------	-----------------------------------------------------------------------------------------------------------------------------------------------------------------------------------------------------------------------------------------------------------	----------------------------------------------------------------------------------------------------------------------------------------------------------------------------------------------------------------------	--------------------------------------------------------	-------------------------------------------------------	---------------------------------	--------------------------------------------	--	--

Elevated Terminal Block	
Part No.:	A13Q010
Customer:	

DRW:	Jason	CHKD	Wilson	MATL:	Wilson	TOLERANCE	Mason	DATE	11.02.2011
APPD:	Schumi			FINISH	Jamy		Sheet No.	3 from 4	



Soldering Profile Curve

Classification Reflow Profile (JEDEC J-STD-020C)

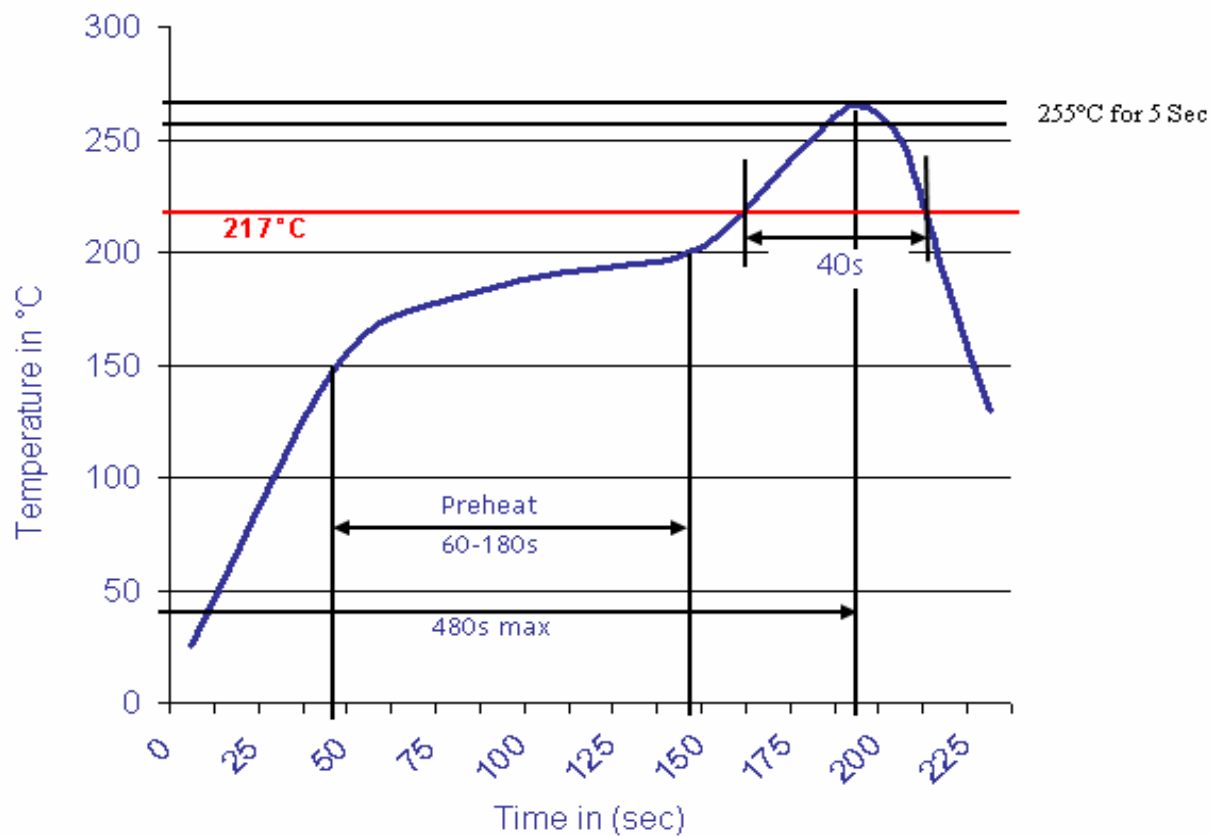

Elevated Terminal Block	
Part No.:	A13Q010
Customer:	

DRW:	Jason	CHKD	Wilson	MATL:	Wilson	TOLERANCE	Mason	DATE	11.02.2011
APPD:	Schumi			FINISH	Jamy		Sheet No.	4 from 4	