

Data Sheet

Elevated Terminal Block

Pitch: 5,00 mm

Serie: A13L036

Customer Information for special Item

EDCON Customer : 0

Customer Version No. : 0

EDCON-COMPONENTS



Technical Discription

Drawing (Dimension in mm)

Electrical

| | |
|-----------------------|----------------|
| Rated Voltage | 400 Volt |
| Rated Current | 24A |
| Wire Range | |
| Solid Wire | AWG 12~26 |
| Stranged Wire | AWG 12~26 |
| Withstanding Voltage | 2,5KV |
| Insulation Resistance | 5000MΩ / 1000V |

Mechanical

| | |
|-----------------------|----------------|
| Operating Temperature | -40°C ~ +115°C |
| Wire Strip Length | 7mm |

Dimensions

| | |
|------------|---------------------|
| Pitch (mm) | 5,00 |
| Poles | 2 + 3Pos. ~ 24 Pos. |

Materials

| | |
|--------------------------|--------------------------|
| 1 Terminal Housing | Thermoplastic (UL94V-0) |
| 2 Clamp | Brass Ni, plated |
| 3 Wire guard | Wire guard solder Pin |
| 4 Terminal screw | Steel Zinc plating |
| 5 Terminal Housing Cover | Thermoplastic (UL94V-0) |

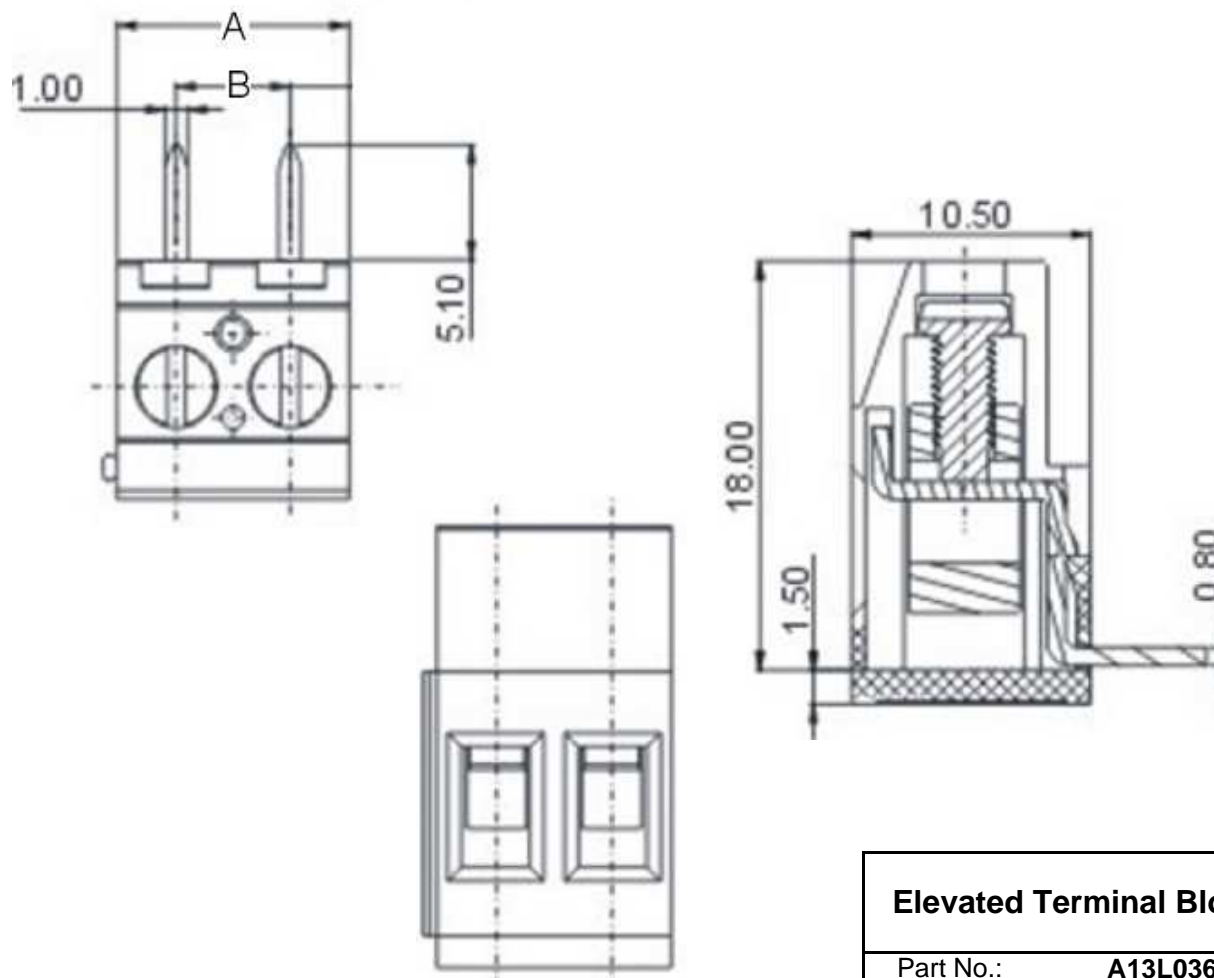

Elevated Terminal Block

Part No.: **A13L036**

Customer:

| | | | | | | | | | |
|-------|--------|------|--------|--------|--------|-----------|-----------|------|------------|
| DRW: | Jason | CHKD | Wilson | MATL: | Wilson | TOLERANCE | Mason | DATE | 12.02.2011 |
| APPD: | Schumi | | | FINISH | Jamy | | Sheet No. | | 1 from 4 |

EDCON-COMPONENTS



PCB Layout

Dimensions (mm)

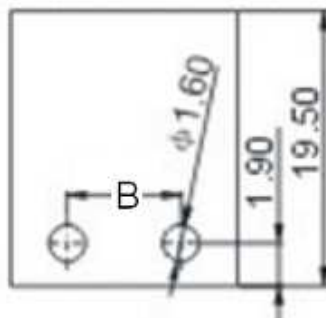

Customer Special Information (Picture, Drawing)

| No. of Pos. | A | Tol. A | B | Tol. B |
|-------------|--------|--------|--------|--------|
| 02 | 10,00 | ± 0,15 | 5,00 | ± 0,15 |
| 03 | 15,00 | ± 0,15 | 10,00 | ± 0,15 |
| 04 | 20,00 | ± 0,15 | 15,00 | ± 0,15 |
| 05 | 25,00 | ± 0,15 | 20,00 | ± 0,15 |
| 06 | 30,00 | ± 0,15 | 25,00 | ± 0,15 |
| 07 | 35,00 | ± 0,25 | 30,00 | ± 0,25 |
| 08 | 40,00 | ± 0,25 | 35,00 | ± 0,25 |
| 09 | 45,00 | ± 0,25 | 40,00 | ± 0,25 |
| 10 | 50,00 | ± 0,25 | 45,00 | ± 0,25 |
| 11 | 55,00 | ± 0,25 | 50,00 | ± 0,25 |
| 12 | 60,00 | ± 0,25 | 55,00 | ± 0,25 |
| 13 | 65,00 | ± 0,35 | 60,00 | ± 0,35 |
| 14 | 70,00 | ± 0,35 | 65,00 | ± 0,35 |
| 15 | 75,00 | ± 0,35 | 70,00 | ± 0,35 |
| 16 | 80,00 | ± 0,35 | 75,00 | ± 0,35 |
| 17 | 85,00 | ± 0,35 | 80,00 | ± 0,35 |
| 18 | 90,00 | ± 0,35 | 85,00 | ± 0,35 |
| 19 | 95,00 | ± 0,35 | 90,00 | ± 0,35 |
| 20 | 100,00 | ± 0,40 | 95,00 | ± 0,40 |
| 21 | 105,00 | ± 0,40 | 100,00 | ± 0,40 |
| 22 | 110,00 | ± 0,40 | 105,00 | ± 0,40 |
| 23 | 115,00 | ± 0,40 | 110,00 | ± 0,40 |
| 24 | 120,00 | ± 0,40 | 115,00 | ± 0,40 |

Elevated Terminal Block

Part No.: **A13L036**

| | | | | | | | | | |
|-------|--------|------|--------|--------|--------|-----------|-----------|----------|------------|
| DRW: | Jason | CHKD | Wilson | MATL: | Wilson | TOLERANCE | Mason | DATE | 12.02.2011 |
| APPD: | Schumi | | | FINISH | Jamy | | Sheet No. | 2 from 4 | |

Customer:



EDCON-COMPONENTS



Ordering Informations

| Serie | No. of Pos. | Body Color | No Function | Approval Code | ROHS | Packing | EDCON Cust. No. | Customer Version | | |
|-------|-------------|------------|-------------|---------------|------|---------|-----------------|------------------|--|--|
|-------|-------------|------------|-------------|---------------|------|---------|-----------------|------------------|--|--|

| | | | | | | | | | | |
|----------------|-----------|-----------|----------|----------|----------|----------|--|--|--|--|
| A13L036 | 02 | PG | A | N | R | B | | | | |
|----------------|-----------|-----------|----------|----------|----------|----------|--|--|--|--|

| | | | | | | | | | | |
|---------------|--|---|---|---|--|---|--------------------------------|--|--|--|
| Pitch 5,00 | 02= Number of Pos. Standard 2 + 3Pos- ~ 24Pos. | PG= Phoenix Green (Standard) WH= White GN= Green GY= Gray LG= Light Gray OR= Orange BL= Blue BK= Black | A= Slotted Screw Type (Standard)  B= Cross Slotted Screw Type  | N= NON Approval A= UL /UR Approval Please consult EDCON for available B= VDE Approval Please consult EDCON for available C= TÜV Approval Please consult EDCON for available | R= ROHS Conform N= NON ROHS Conform | B= Bulk-Ware I= Individual Package | xxxxxx= Customer Number | xxx= Customer Version ??(Printing) | | |
|---------------|--|---|---|---|--|---|--------------------------------|--|--|--|

| Elevated Terminal Block | |
|-------------------------|----------------|
| Part No.: | A13L036 |
| Customer: | |

| | | | | | | | | | |
|-------|--------|------|--------|--------|--------|-----------|-----------|----------|------------|
| DRW: | Jason | CHKD | Wilson | MATL: | Wilson | TOLERANCE | Mason | DATE | 12.02.2011 |
| APPD: | Schumi | | | FINISH | Jamy | | Sheet No. | 3 from 4 | |



Soldering Profile Curve

Classification Reflow Profile (JEDEC J-STD-020C)

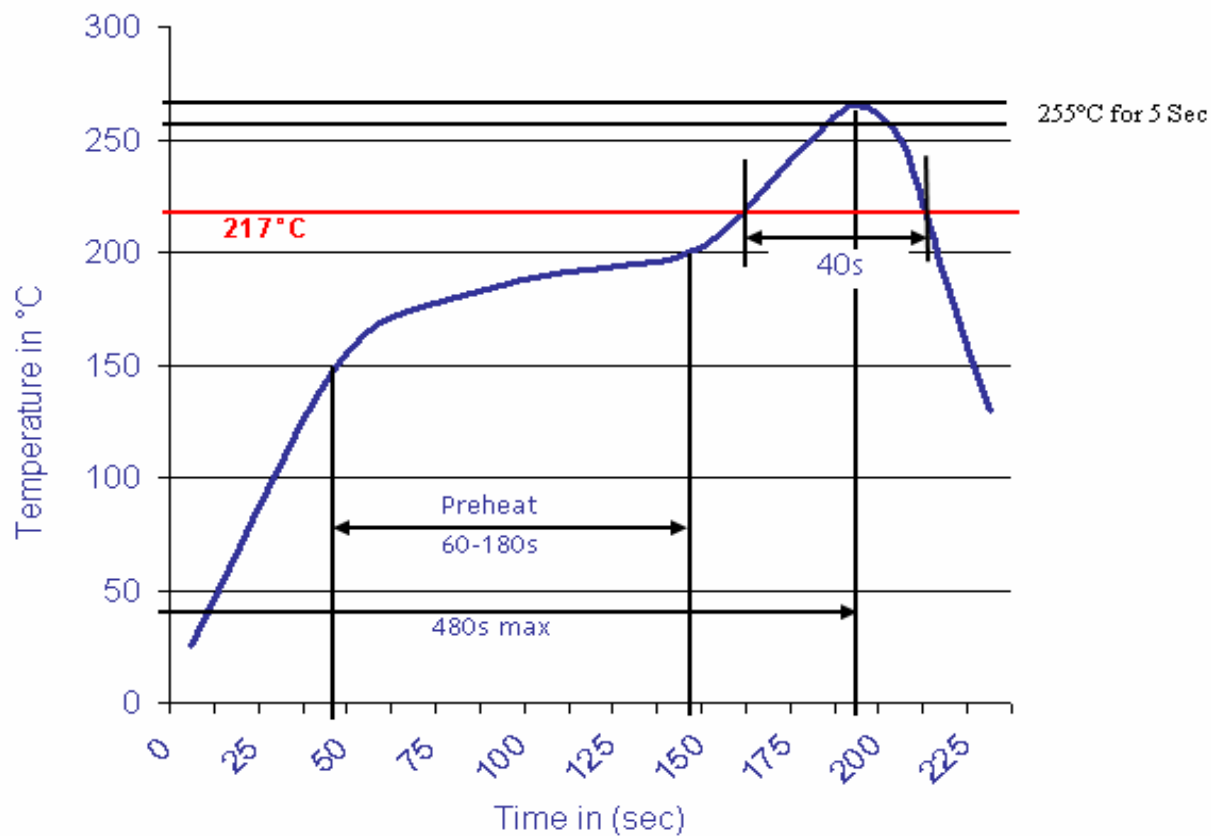

| | |
|--------------------------------|----------------|
| Elevated Terminal Block | |
| Part No.: | A13L036 |
| Customer: | |

| | | | | | | | | | |
|-------|--------|------|--------|--------|--------|-----------|-----------|----------|------------|
| DRW: | Jason | CHKD | Wilson | MATL: | Wilson | TOLERANCE | Mason | DATE | 12.02.2011 |
| APPD: | Schumi | | | FINISH | Jamy | | Sheet No. | 4 from 4 | |