

Data Sheet

Elevated Terminal Block

Pitch: 5,00 mm

Serie: A13L015

Customer Information for special Item

EDCON Customer : 0

Customer Version No. : 0

EDCON-COMPONENTS



Technical Description

Drawing (Dimension in mm)

Electrical

Rated Voltage	250 Volt
Rated Current	24A
Wire Range	
Solid Wire	AWG 12~24
Stranded Wire	AWG 12~24
Withstanding Voltage	2,0KV
Insulation Resistance	5000MΩ / 1000V

Mechanical

Operating Temperature	-40°C ~ +115°C
Wire Strip Length	7mm

Dimensions

Pitch (mm)	5,00
Poles	2 + 3Pos. ~ 24 Pos.

Materials

1 Terminal Housing	Thermoplastic (UL94V-0)
2 Clamp	Brass Ni, plated
3 Wire guard	Wire guard solder Pin
4 Terminal screw	Steel Zinc plating
5 Terminal Housing Cover	Thermoplastic (UL94V-0)

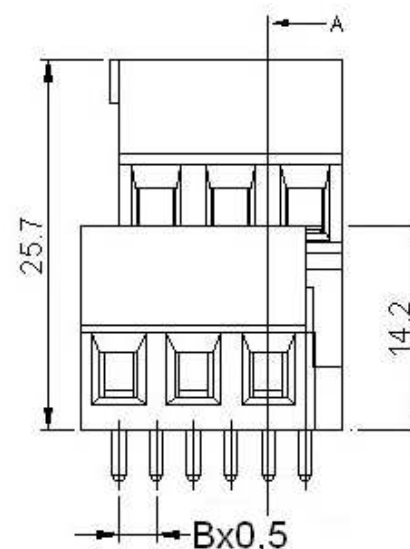
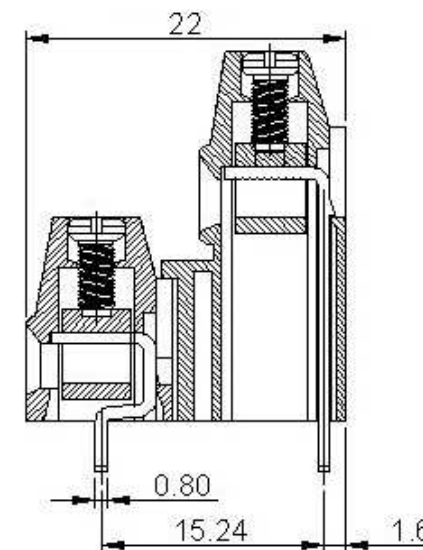
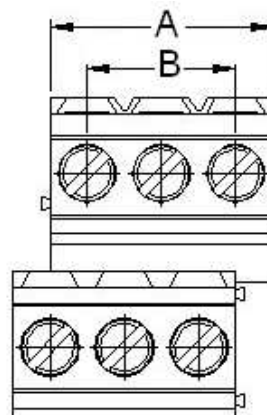

Elevated Terminal Block

Part No.: **A13L015**

Customer:

DRW:	Jason	CHKD	Wilson	MATL:	Wilson	TOLERANCE	Mason	DATE	11.02.2011
APPD:	Schumi			FINISH	Jamy		Sheet No.		1 from 4

EDCON-COMPONENTS



PCB Layout

Dimensions (mm)

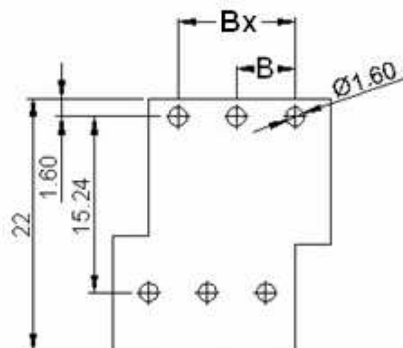

Customer Special Information (Picture, Drawing)

No. of Pos.	A	Tol. A	B	Tol. B
02	10,00	± 0,15	5,00	± 0,15
03	15,00	± 0,15	10,00	± 0,15
04	20,00	± 0,15	15,00	± 0,15
05	25,00	± 0,15	20,00	± 0,15
06	30,00	± 0,15	25,00	± 0,15
07	35,00	± 0,25	30,00	± 0,25
08	40,00	± 0,25	35,00	± 0,25
09	45,00	± 0,25	40,00	± 0,25
10	50,00	± 0,25	45,00	± 0,25
11	55,00	± 0,25	50,00	± 0,25
12	60,00	± 0,25	55,00	± 0,25
13	65,00	± 0,35	60,00	± 0,35
14	70,00	± 0,35	65,00	± 0,35
15	75,00	± 0,35	70,00	± 0,35
16	80,00	± 0,35	75,00	± 0,35
17	85,00	± 0,35	80,00	± 0,35
18	90,00	± 0,35	85,00	± 0,35
19	95,00	± 0,35	90,00	± 0,35
20	100,00	± 0,40	95,00	± 0,40
21	105,00	± 0,40	100,00	± 0,40
22	110,00	± 0,40	105,00	± 0,40
23	115,00	± 0,40	110,00	± 0,40
24	120,00	± 0,40	115,00	± 0,40

Elevated Terminal Block

Part No.: **A13L015**

Customer:

DRW:	Jason	CHKD	Wilson	MATL:	Wilson	TOLERANCE	Mason	DATE	11.02.2011
APPD:	Schumi			FINISH	Jamy		Sheet No.		2 from 4



EDCON-COMPONENTS



Ordering Informations

Serie	No. of Pos.	Body Color	No Function	Approval Code	ROHS	Packing	EDCON Cust. No.	Customer Version		
-------	-------------	------------	-------------	---------------	------	---------	-----------------	------------------	--	--

A13L015	02	PG	A	N	R	B				
----------------	-----------	-----------	----------	----------	----------	----------	--	--	--	--

Pitch 5,00	02 = Number of Pos. Standard 2x2 + 2x3Pos- ~ 2x24Pos.	PG = Phoenix Green (Standard) WH = White GN = Green GY = Gray LG = Light Gray OR = Orange BL = Blue BK = Black	A = Slotted Screw Type (Standard)  B = Cross Slotted Screw Type 	N = NON Approval A = UL /UR Approval Please consult EDCON for available B = VDE Approval Please consult EDCON for available C = TÜV Approval Please consult EDCON for available	R = ROHS Conform N = NON ROHS Conform	B = Bulk-Ware I = Individual Package	xxxxxx = Customer Number	xxx = Customer Version ??(Printing)		
---------------	---	---	---	---	--	---	---------------------------------	---	--	--

Elevated Terminal Block	
Part No.:	A13L015
Customer:	

DRW:	Jason	CHKD	Wilson	MATL:	Wilson	TOLERANCE	Mason	DATE	11.02.2011
APPD:	Schumi			FINISH	Jamy		Sheet No.		3 from 4



Soldering Profile Curve

Classification Reflow Profile (JEDEC J-STD-020C)

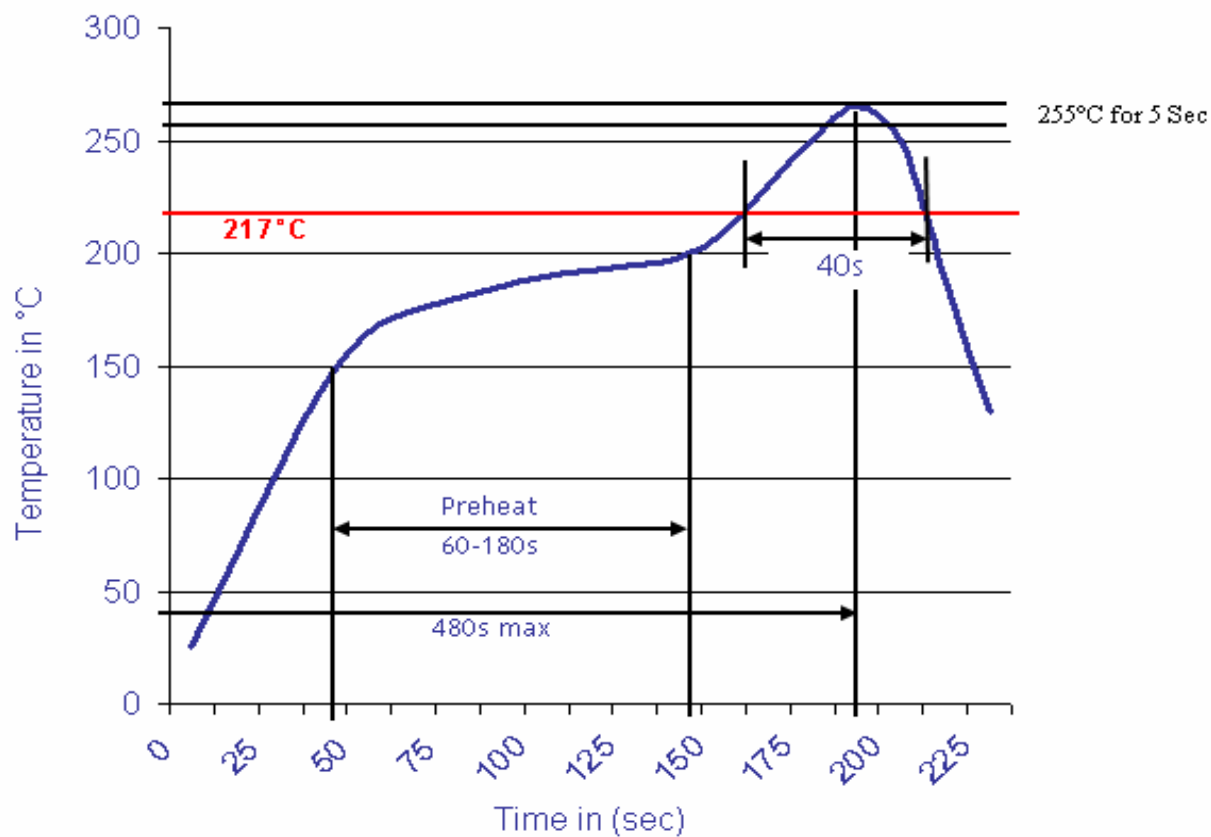

Elevated Terminal Block	
Part No.:	A13L015
Customer:	

DRW:	Jason	CHKD	Wilson	MATL:	Wilson	TOLERANCE	Mason	DATE	11.02.2011
APPD:	Schumi			FINISH	Jamy		Sheet No.	4 from 4	