

EDCON-COMPONENTS



Technical Description

Drawing (Dimension in mm)

Electrical

Rated Voltage	300 Volt
Rated Current	10A
Contact Resistance	20m Ω
Withstanding Voltage	1,6KV
Insulation Resistance	5000MmΩ / 1000V

Mechanical

Operating Temperature	. -40°C ~ +105°C
Wire Strip Length	5-6mm
Screw Torque	1,7
Screw Size	M 2
Wire Range	1,0 ~ 2,5mm ²
Solid Wire	16 ~ 30
Stranged Wire	16 ~ 30

Dimensions

Pitch	3,50mm
Poles	2 + 3 max 24P.

Materials

Housing	Therrmoplastic, UL94V-0
Pin Heder	Brass Tin Plated
Screw	Fe Ni-plated
Cage	Brass Ni Plated

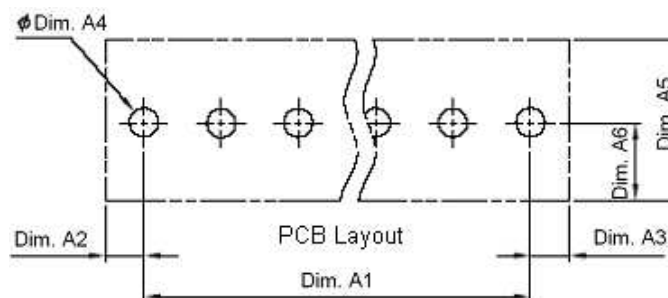

Dimension (mm)

A1=		A5=	
A2=		A6=	
A3=			
A4=			

Terminal Block Pitch 3,50mm Elevated Type

Part No.: **A13G006**

Customer:



DRW:	Jason	CHKD	Wilson	MATL:	Wilson	TOLERANCE	Mason	DATE	05.02.2011
APPD:	Schumi			FINISH	Jamy		Sheet No.	1 from 3	

EDCON-COMPONENTS



Ordering Informations

Serie	No. of Pos.	Body Color	Screw Type	Approval Code	ROHS	Packing	EDCON Cust. No.	Customer Version		
A13G006	02	PG	A	N	R	B	xxxxxx	xxx		

02= Number of Pos.	PG= Phoenix Green (Standard)	A= Slotted Screw Type (Standard)	N= NON Approval	R= ROHS Conform	B= Bulk-Ware	xxxxxx= Customer Number	xxx= Customer Version ??(Printing)
Standard 2 + 3 Pos.	WH= White	B= Cross Slotted Screw Type	A= UL /UR Approval	N= NON ROHS Conform			
Other Position on Request	GN= Green	Screw Type A 					
	GN= Gray						
	LG= Light Gray						
	OR= Orange	Screw Type B 					
	BL= Blue						
	BK= Black						

**Terminal Block Pitch
3,50mm Elevated Type**

Part No.: **A13G006**

DRW:	Jason	CHKD	Wilson	MATL:	Wilson	TOLERANCE	Mason	DATE	05.02.2011
APPD:	Schumi			FINISH	Jamy			Sheet No.	2 from 3

Customer:



Soldering Profile Curve

Classification Reflow Profile (JEDEC J-STD-020C)

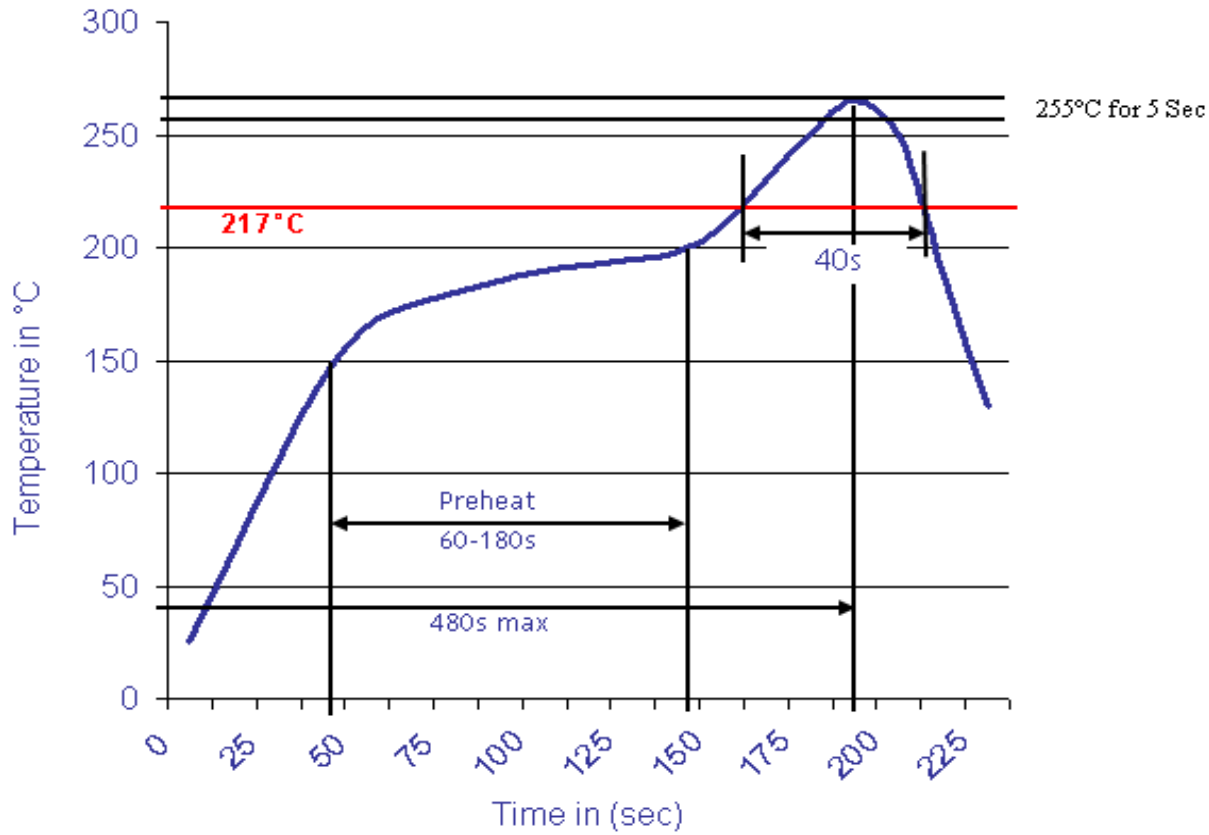

Terminal Block Pitch 3,50mm Elevated Type	
Part No.:	A13G006
Customer:	

DRW:	Jason	CHKD	Wilson	MATL:	Wilson	TOLERANCE	Mason	DATE	05.02.2011
APPD:	Schumi			FINISH	Jamy		Sheet No.	3 from 3	