

# EDCON-COMPONENTS



## Technical Discription

## Drawing (Dimension in mm)

### Electrical

Rated Voltage	300 Volt
Rated Current	10A
Contact Resistance	20m Ω
Withstanding Voltage	1,6KV
Insulation Resistance	5000MmΩ / 1000V

### Mechanical

Operating Temperature	-40°C ~ +105°C
Wire Strip Length	5-6mm
Screw Torque	1,7
Screw Size	M 2
Wire Range	1,0 ~ 2,5mm <sup>2</sup>
Solid Wire	16 ~ 24
Stranged Wire	16 ~ 24

### Dimensions

Pitch	3,50mm
Poles	2 + 3 max 24P.

### Materials

Housing	PA66, UL94V-0
Pin Heder	Brass Tin Plated
Screw	Fe Ni-plated
Cage	Brass Ni Plated

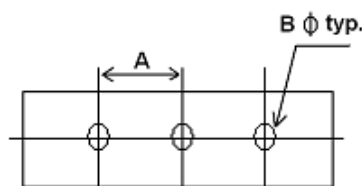
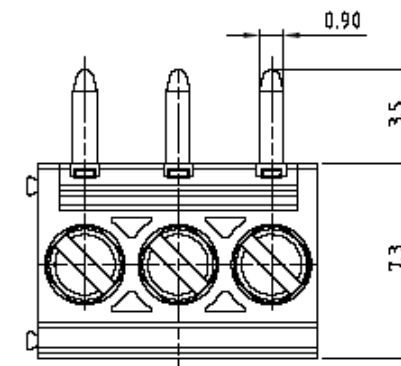
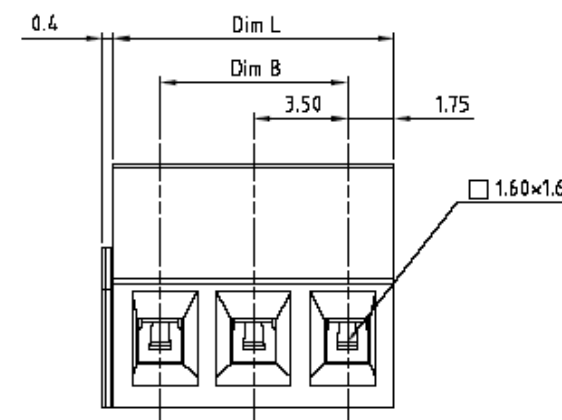
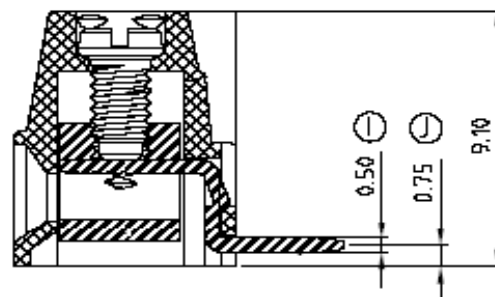

PCB Layout

A= 3,50mm

B= 1,3mm

**Terminal Block Pitch  
3,50mm Elevated Type**

Part No.: **A13G003**

Customer:



DRW:	Jason	CHKD	Wilson	MATL:	Wilson	TOLERANCE	Mason	DATE	05.02.2011
APPD:	Schumi			FINISH	Jamy		Sheet No.	1 from 3	

# EDCON-COMPONENTS



## Ordering Informations

Serie	No. of Pos.	Body Color	Screw Type	Approval Code	ROHS	Packing	EDCON Cust. No.	Customer Version		
<b>A13G003</b>	<b>02</b>	<b>PG</b>	<b>A</b>	<b>N</b>	<b>R</b>	<b>B</b>	<b>xxxxxx</b>	<b>xxx</b>		

<b>02=</b> Number of Pos.	<b>PG=</b> Phoenix Green (Standard)	<b>A=</b> Slotted Screw Type (Standard)	<b>N=</b> NON Approval	<b>R=</b> ROHS Conform	<b>B=</b> Bulk-Ware	<b>xxxxxx=</b> Customer Number	<b>xxx=</b> Customer Version ??(Printing)
Standard 2 + 3 Pos.	<b>WH=</b> White	<b>B=</b> Cross Slotted Screw Type	<b>A=</b> UL /UR Approval	<b>N=</b> NON ROHS Conform			
Other Position on Request	<b>GN=</b> Green	<b>Screw Type A</b> 					
	<b>GN=</b> Gray						
	<b>LG=</b> Light Gray						
	<b>OR=</b> Orange	<b>Screw Type B</b> 					
	<b>BL=</b> Blue						
	<b>BK=</b> Black						

**Terminal Block Pitch  
3,50mm Elevated Type**

Part No.: **A13G003**

DRW:	Jason	CHKD	Wilson	MATL:	Wilson	TOLERANCE	Mason	DATE	05.02.2011
APPD:	Schumi			FINISH	Jamy			Sheet No.	2 from 3

Customer:



Soldering Profile Curve

Classification Reflow Profile (JEDEC J-STD-020C)

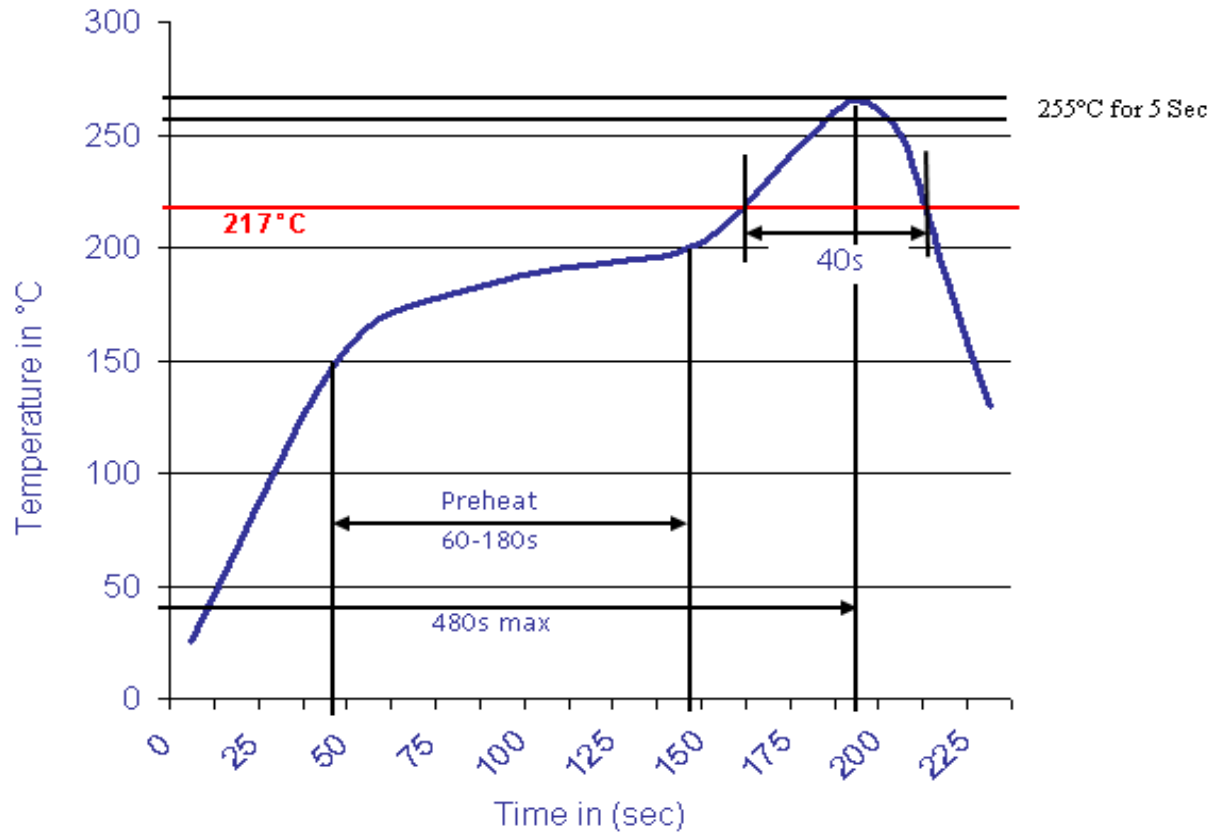

<b>Terminal Block Pitch 3,50mm Elevated Type</b>	
Part No.:	<b>A13G003</b>
Customer:	

DRW:	Jason	CHKD	Wilson	MATL:	Wilson	TOLERANCE	Mason	DATE	05.02.2011
APPD:	Schumi			FINISH	Jamy		Sheet No.	3 from 3	