

# EDCON-COMPONENTS

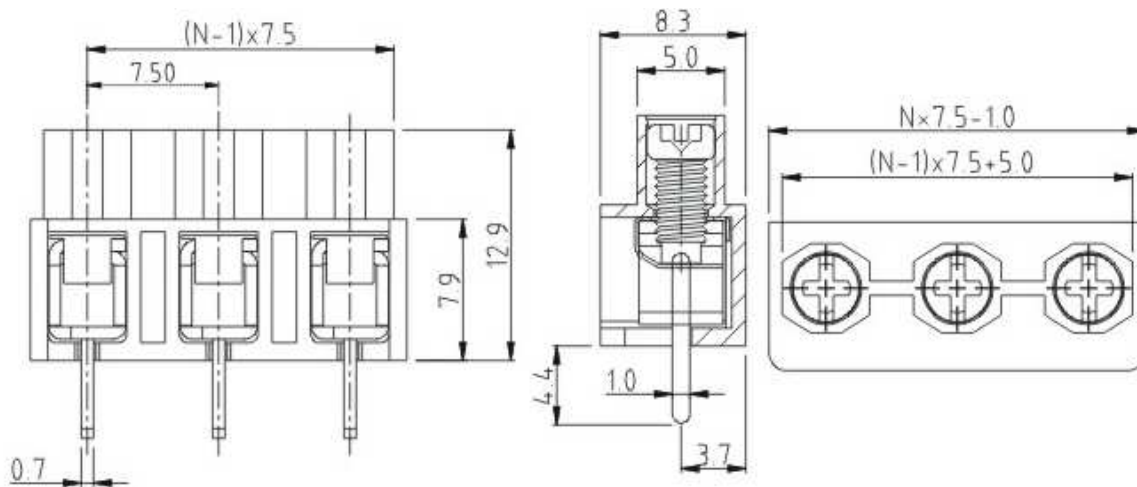

## Drawing



## P.C.B. Layout

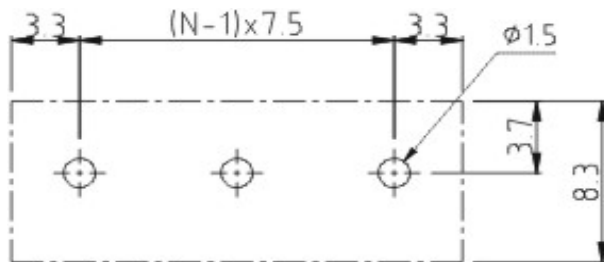

## Specification

### APPROVAL



#### Electrical

Standard  
Rated voltage  
Rated current  
Wire range  
Withstanding voltage

cULus  
300V  
10A  
20-12 AWG  
1.6KV

#### Mechanical

Ambient temperature  
Soldering temperature  
Strip length  
Screw, Torque

-40°C ~ +115°C  
250°C ± 10°C/5 sec  
6 ~ 7mm  
M3, 0.4Nm (3.5Lb-In.)

#### Dimensions

Pitch  
Poles

7.50mm  
2P - 16P

#### Material

Housing  
Surface of solder tail  
Wire guard  
Terminal screw  
Metal housing

Thermoplastic (UL94V-0)  
Tin plated  
Stainless steel  
Steel Zinc plated  
Brass stamped



Wire Protector Terminal Block /  
Pitch 7.50mm

Part No.: A12Q007

DRW:	Bill	CHKD	Lord	MATL:	Jimmy	TOLERANCE	Sam	DATE	14.03.2009	Customer:
APPD:	Louis			FINISH	Georg			Sheet No.	1 from 3	

[www.edcon-components.com](http://www.edcon-components.com)

email: [info@edcon-components.com](mailto:info@edcon-components.com)

# EDCON-COMPONENTS



## Ordering Informations

Serie	-	No. of Pole	Body-Color	wire protector	Screw	-	Customer Request
A12Q007	-	XX	XX	X	X	-	X

XX = total	WH - white	1 - with wire protector	A - Slotted screw
02	GN - green	2 - without wire protector	B - Cross-slotted screw (standard)
...	GR - gray		
16	LG - light gray		



PG - Phoenix Green
OR - orange
BL - blue
BK - black



wire protector

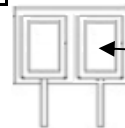

without wire protector



**Certification**



Wire Protector Terminal Block /  
Pitch 7.50mm

Part No.: A12Q007

Customer:

DRW:	Bill	CHKD	Lord	MATL:	Jimmy	TOLERANCE	Sam	DATE	14.03.2009
APPD:	Louis			FINISH	Georg		Sheet No.	2 from 3	

[www.edcon-components.com](http://www.edcon-components.com)

email: [info@edcon-components.com](mailto:info@edcon-components.com)

# EDCON-COMPONENTS



## Soldering - Profil

### Classification Reflow Profile (JEDEC J-STD-020C)



Wire Protector Terminal Block /  
Pitch 7.50mm

Part No.: A12Q007

Customer:

DRW:	Bill	CHKD	Lord	MATL:	Jimmy	TOLERANCE	Sam	DATE	14.03.2009
APPD:	Louis			FINISH	Georg		Sheet No.	3 from 3	

[www.edcon-components.com](http://www.edcon-components.com)

email: [info@edcon-components.com](mailto:info@edcon-components.com)