

# EDCON-COMPONENTS

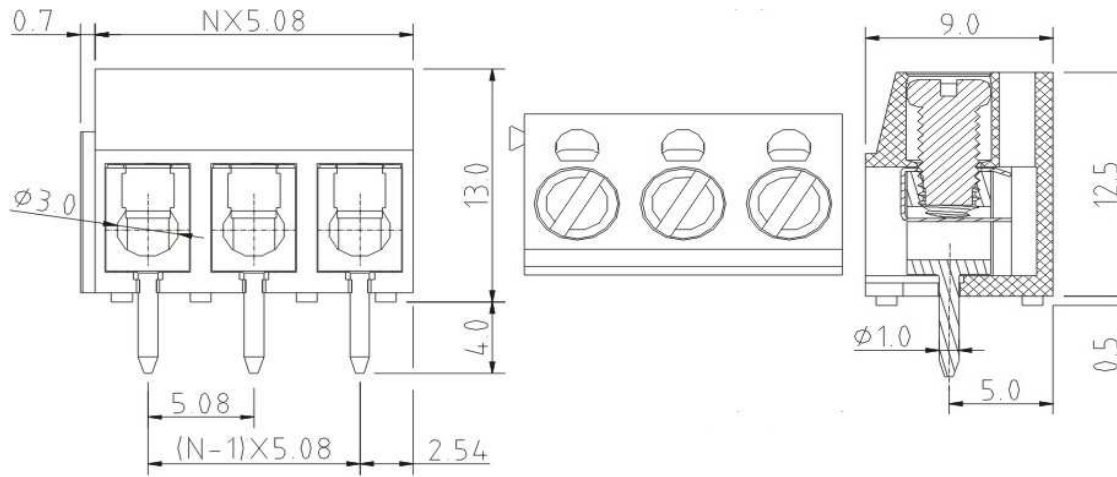

## Drawing



## P.C.B. Layout

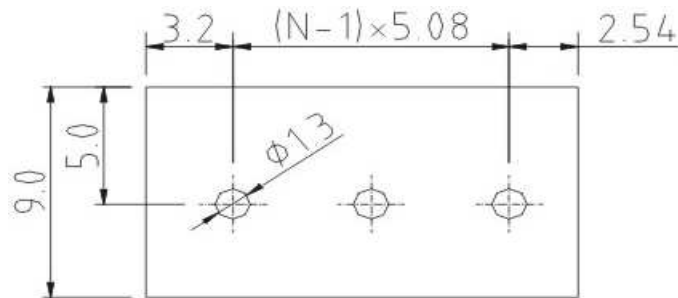

## Specification

### APPROVAL



#### Electrical

Standard  
Rated voltage  
Rated current  
Wire range  
Withstanding voltage

UL  
300V  
15A  
22-14 AWG  
1.6KV

#### Mechanical

Ambient temperature  
Soldering temperature  
Strip length  
Screw, Torque

-40°C ~ +115°C  
250°C ± 10°C/5 sec  
6 ~ 7mm  
M3, 0.4 Nm (3.5Lb-In.)

#### Dimensions

Pitch  
Poles

5.08mm  
2P, 3P

#### Material

Housing  
Surface of solder tail  
Wire guard  
Terminal screw  
Metal housing

Thermoplastic (UL94V-0)  
Tin plated  
Stainless steel  
Steel Zinc plated  
Brass (CuZn)



Wire Protector Terminal Block /  
Pitch 5.08mm

Part No.: A12M001

Customer:

DRW:	Bill	CHKD	Lord	MATL:	Jimmy	TOLERANCE	Sam	DATE	14.03.2009
APPD:	Louis			FINISH	Georg			Sheet No.	1 from 3

[www.edcon-components.com](http://www.edcon-components.com)

email: [info@edcon-components.com](mailto:info@edcon-components.com)

Copyright by EDCON-COMPONENTS

# EDCON-COMPONENTS



## Ordering Informations

Serie	-	No. of Pole	Body-Color	wire protector	Screw	-	Customer Request
<b>A12M001</b>	-	<b>XX</b>	<b>XX</b>	<b>X</b>	<b>X</b>	-	<b>X</b>

XX = total	<b>WH</b> - white	<b>1</b> - with wire protector	<b>A</b> - Slotted screw ( <i>standard</i> )
02	<b>GN</b> - green	<b>2</b> - without wire protector	<b>B</b> - Cross-slotted screw
03	<b>GR</b> - gray		

<b>LG</b> - light gray
<b>PG</b> - Phoenix Green
<b>OR</b> - orange
<b>BL</b> - blue
<b>BK</b> - black

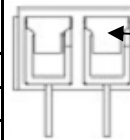

wire protector

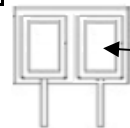

without wire protector



Certification



Wire Protector Terminal Block /  
Pitch 5.08mm

Part No.: A12M001

Customer:

DRW:	Bill	CHKD	Lord	MATL:	Jimmy	TOLERANCE	Sam	DATE	14.03.2009
APPD:	Louis			FINISH	Georg		Sheet No.		2 from 3

[www.edcon-components.com](http://www.edcon-components.com)

email: [info@edcon-components.com](mailto:info@edcon-components.com)

# EDCON-COMPONENTS



## Soldering - Profil

### Classification Reflow Profile (JEDEC J-STD-020C)

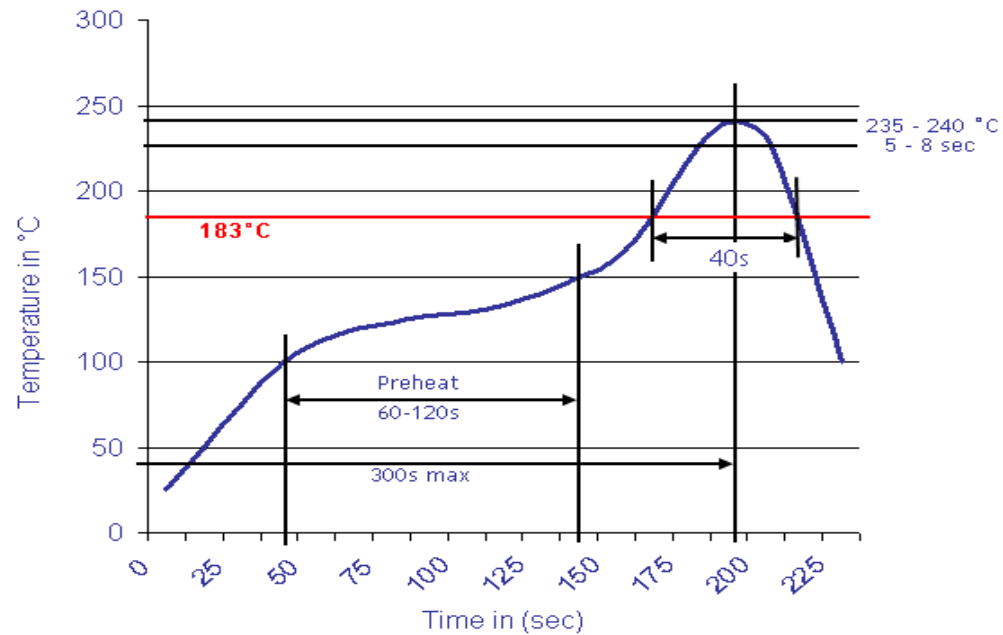

Wire Protector Terminal Block /  
Pitch 5.08mm

Part No.: A12M001

Customer:

DRW:	Bill	CHKD	Lord	MATL:	Jimmy	TOLERANCE	Sam	DATE	14.03.2009
APPD:	Louis			FINISH	Georg		Sheet No.	3 from 3	

[www.edcon-components.com](http://www.edcon-components.com)

email: [info@edcon-components.com](mailto:info@edcon-components.com)



