

# EDCON-COMPONENTS

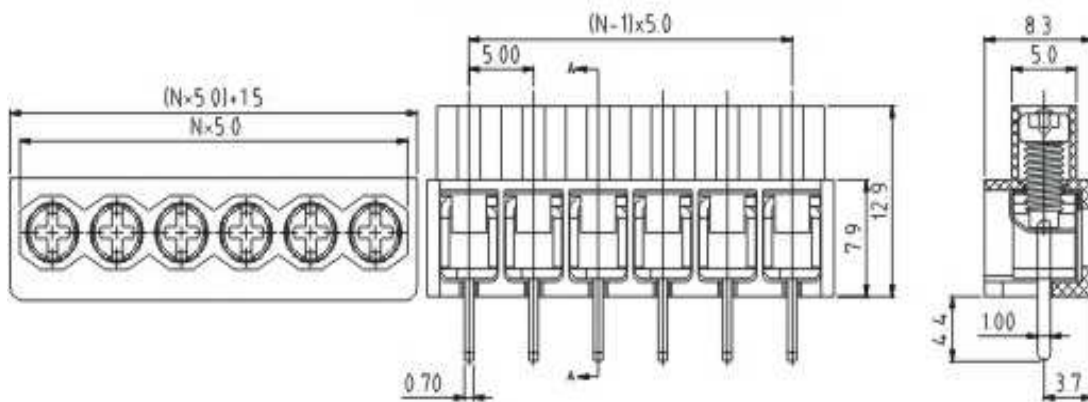

## Drawing



## P.C.B. Layout

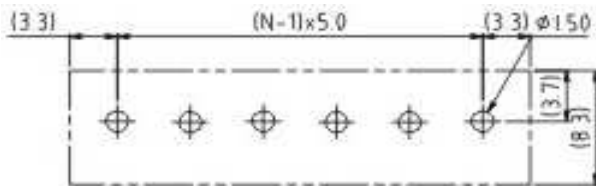

## Specification

### APPLYING APPROVAL

(cULus) pending

#### Electrical

Standard	cULus
Rated voltage	300V
Rated current	10A
Wire range	20-12 AWG
Withstanding voltage	1.6KV

#### Mechanical

Ambient temperature	-40°C ~ +115°C
Soldering temperature	250°C $\pm$ 10°C/5 sec
Strip length	6 ~ 7mm
Screw, Torque	M3, 0.4Nm (3.5Lb-In)

#### Dimensions

Pitch	5.00mm
Poles	2P - 24P

#### Material

Housing	Thermoplastic (UL94V-0)
Surface of solder tail	Tin plated
Wire guard	Stainless steel
Terminal screw	Steel Zinc plated
Metal housing	Brass stamped



Wire Protector Terminal Block /  
Pitch 5.00mm

Part No.: A12L051

Customer:

DRW:	Bill	CHKD	Lord	MATL:	Jimmy	TOLERANCE	Sam	DATE	14.03.2009
APPD:	Louis			FINISH	Georg			Sheet No.	1 from 3

[www.edcon-components.com](http://www.edcon-components.com)

email: [info@edcon-components.com](mailto:info@edcon-components.com)

# EDCON-COMPONENTS



## Ordering Informations

Serie	-	No. of Pole	Body-Color	wire protector	Screw	-	Customer Request
A12L051	-	XX	XX	X	X	-	X

XX = total	WH - white	1 - with wire protector	A - Slotted screw
02	GN - green	2 - without wire protector	B - Cross-slotted screw (standard)
...	GR - gray		
24	LG - light gray		

PG - Phoenix Green
OR - orange
BL - blue
BK - black

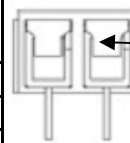

wire protector

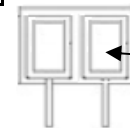

without wire protector



Certification



Wire Protector Terminal Block /  
Pitch 5.00mm

Part No.: A12L051

Customer:

DRW:	Bill	CHKD	Lord	MATL:	Jimmy	TOLERANCE	Sam	DATE	14.03.2009
APPD:	Louis			FINISH	Georg		Sheet No.		2 from 3

[www.edcon-components.com](http://www.edcon-components.com)

email: [info@edcon-components.com](mailto:info@edcon-components.com)



## Soldering - Profil

### Classification Reflow Profile (JEDEC J-STD-020C)

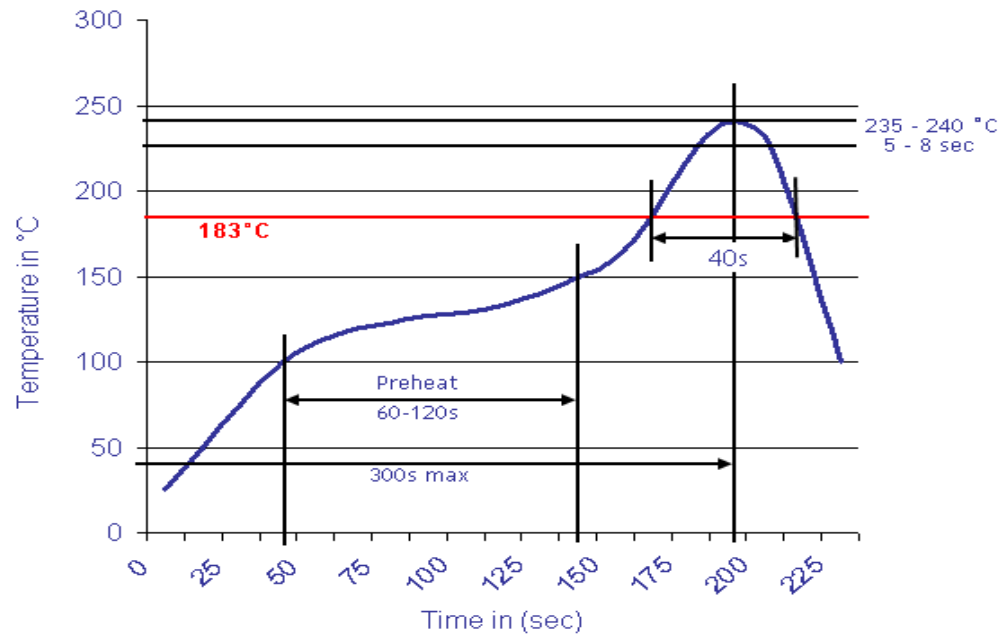

Wire Protector Terminal Block /  
Pitch 5.00mm

Part No.: A12L051

Customer:

DRW:	Bill	CHKD	Lord	MATL:	Jimmy	TOLERANCE	Sam	DATE	14.03.2009
APPD:	Louis			FINISH	Georg		Sheet No.	3 from 3	