

EDCON-COMPONENTS

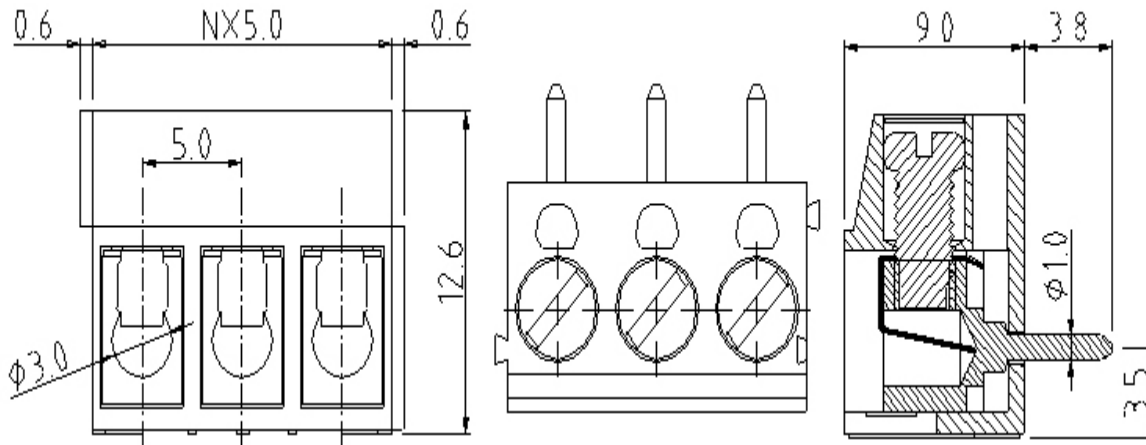

Drawing



P.C.B. Layout

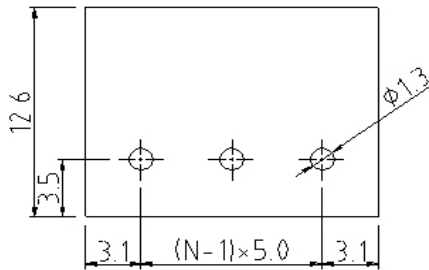

Specification

APPROVAL



Electrical

Standard	UL
Rated voltage	250V
Rated current	16A
Wire range	14AWG
Withstanding voltage	1.5KV

Mechanical

Ambient temperature	-40°C ~ +115°C
Soldering temperature	250°C ± 10°C/5 sec
Strip length	6 ~ 7mm
Screw, Torque	M3, 0.3Nm (2.6Lb-In)

Dimensions

Pitch	5.00mm
Poles	2P, 3P

Material

Housing	Thermoplastic (UL94V-0)
Surface of solder tail	Tin plated
Wire guard	Stainless steel
Terminal screw	Steel Zinc plated
Metal housing	Brass (CuZn)



Wire Protector Terminal Block /
Pitch 5.00mm

Part No.: A12L037

DRW:	Bill	CHKD	Lord	MATL:	Jimmy	TOLERANCE	Sam	DATE	14.03.2009	Customer:
APPD:	Louis			FINISH	Georg			Sheet No.	1 from 3	

www.edcon-components.com

email: info@edcon-components.com

EDCON-COMPONENTS



Ordering Informations

Serie	-	No. of Pole	Body-Color	wire protector	Screw	-	Customer Request
A12L037	-	XX	XX	X	X	-	X

XX = total	WH - white	1 - with wire protector	A - Slotted screw <i>(standard)</i>
02	GN - green	2 - without wire protector	B - Cross-slotted screw
03	GR - gray		

LG - light gray
PG - Phoenix Green
OR - orange <i>(standard)</i>
BK - black
BL - blue

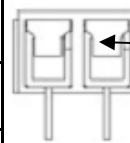

wire protector

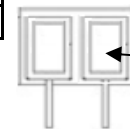

without wire protector



Certification



Wire Protector Terminal Block /
Pitch 5.00mm

Part No.: A12L037

Customer:

DRW:	Bill	CHKD	Lord	MATL:	Jimmy	TOLERANCE	Sam	DATE	14.03.2009
APPD:	Louis			FINISH	Georg			Sheet No.	2 from 3

www.edcon-components.com

email: info@edcon-components.com



Soldering - Profil

Classification Reflow Profile (JEDEC J-STD-020C)

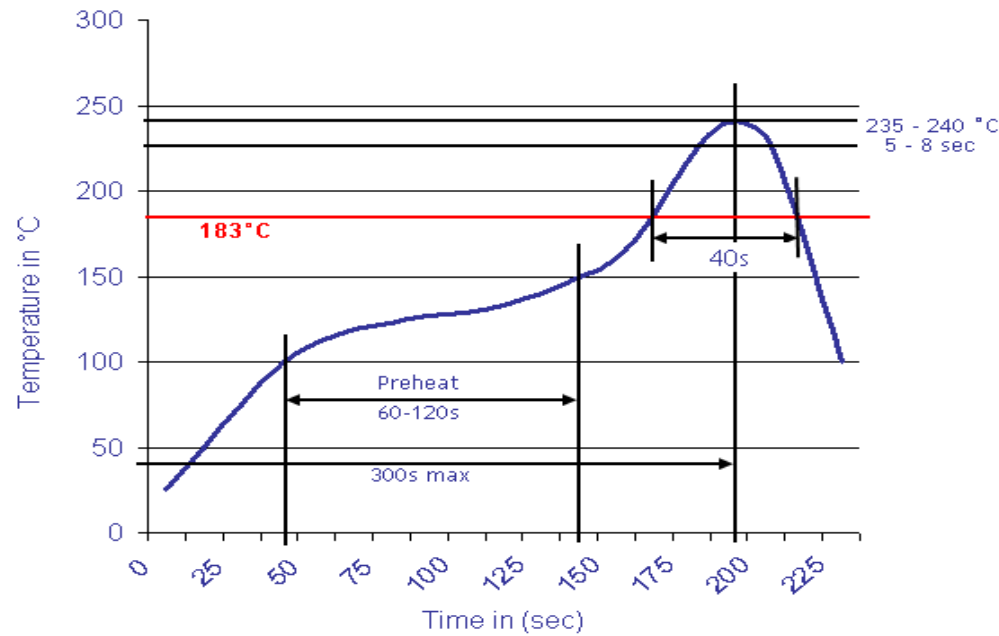

Wire Protector Terminal Block /
Pitch 5.00mm

Part No.: A12L037

Customer:

DRW:	Bill	CHKD	Lord	MATL:	Jimmy	TOLERANCE	Sam	DATE	14.03.2009
APPD:	Louis			FINISH	Georg		Sheet No.	3 from 3	