

EDCON-COMPONENTS

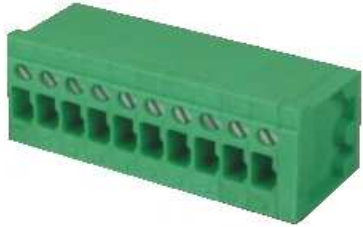

Drawing

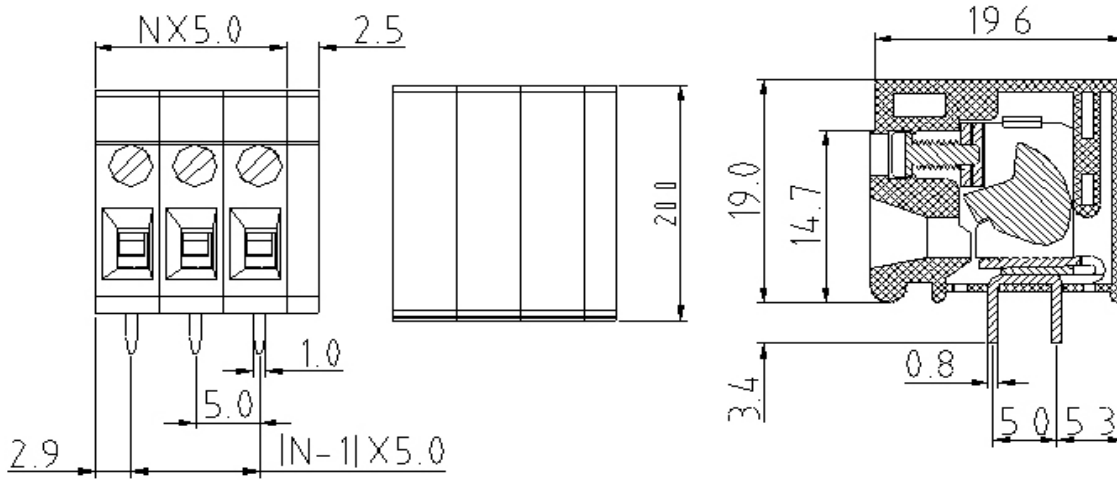

P.C.B. Layout

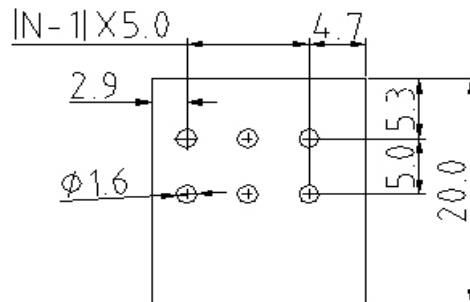

Specification

APPROVAL



Electrical

Standard
Rated voltage
Rated current
Wire range
Withstanding voltage

cULus
300V
20A
22-12 AWG
1.6KV

Mechanical

Ambient temperature
Soldering temperature
Strip length
Screw, Torque

-40°C ~ +115°C
250°C \pm 10°C/5 sec
10 ~ 11mm
M2.5, 0.3Nm (2.4Lb-In.)

Dimensions

Pitch
Poles

5.00mm
2P - 24P

Material

Housing
Surface of solder tail
Contact
Terminal screw
Metal housing

Thermoplastic (UL94V-0)
Tin plated
Brass
Steel Zinc plated
Steel stamped



Wire Protector Terminal Block /
Pitch 5.00mm

Part No.: A12L019

Customer:

| | | | | | | | | | |
|-------|-------|------|------|--------|-------|-----------|-----|-----------|------------|
| DRW: | Bill | CHKD | Lord | MATL: | Jimmy | TOLERANCE | Sam | DATE | 14.03.2009 |
| APPD: | Louis | | | FINISH | Georg | | | Sheet No. | 1 from 3 |

www.edcon-components.com

email: info@edcon-components.com

Copyright by EDCON-COMPONENTS

EDCON-COMPONENTS

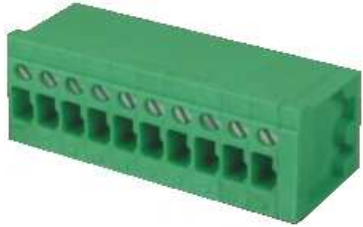

Ordering Informations

| Serie | - | No. of Pole | Body-Color | wire protector | Screw | - | Customer Request |
|---------|---|-------------|------------|----------------|-------|---|------------------|
| A12L019 | - | XX | XX | X | X | - | X |

| | | | |
|------------|-----------------|----------------------------|------------------------------|
| XX = total | WH - white | 1 - with wire protector | A - Slotted screw (standard) |
| 02 | GN - green | 2 - without wire protector | B - Cross-slotted screw |
| ... | GR - gray | | |
| 24 | LG - light gray | | |

| |
|--------------------|
| PG - Phoenix Green |
| OR - orange |
| BL - blue |
| BK - black |

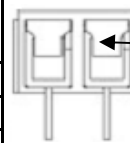

wire protector

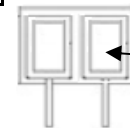

without wire protector



Certification



Wire Protector Terminal Block /
Pitch 5.00mm

Part No.: A12L019

Customer:

| | | | | | | | | | |
|-------|-------|------|------|--------|-------|-----------|-----------|------|------------|
| DRW: | Bill | CHKD | Lord | MATL: | Jimmy | TOLERANCE | Sam | DATE | 14.03.2009 |
| APPD: | Louis | | | FINISH | Georg | | Sheet No. | | 2 from 3 |

www.edcon-components.com

email: info@edcon-components.com

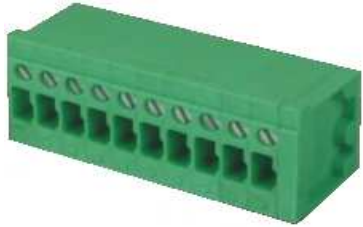

Soldering - Profil

Classification Reflow Profile (JEDEC J-STD-020C)

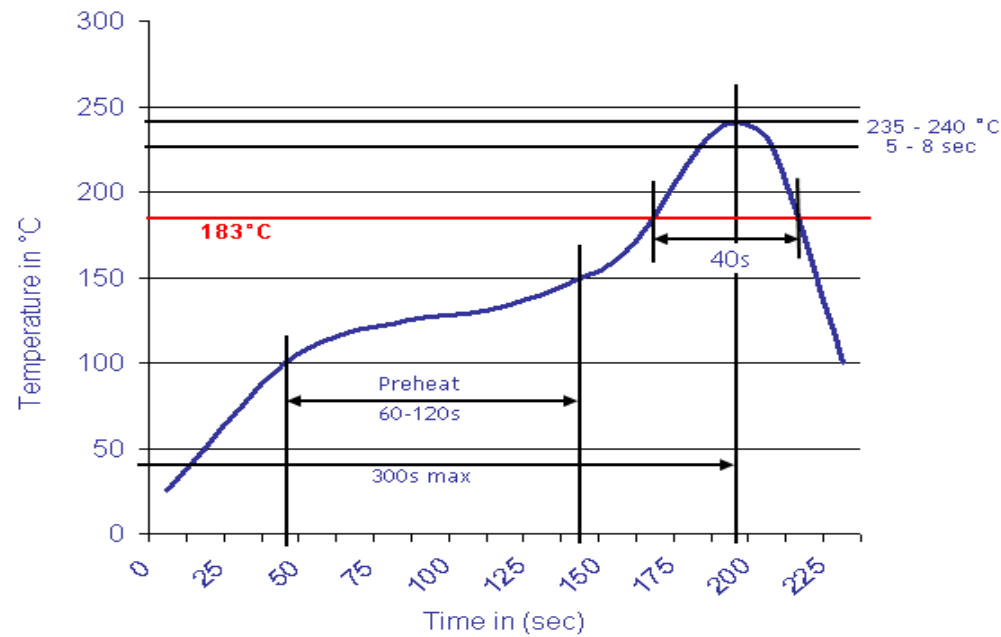

Wire Protector Terminal Block /
Pitch 5.00mm

Part No.: A12L019

| | | | | | | | | | |
|-------|-------|------|------|--------|-------|-----------|-----|-----------|------------|
| DRW: | Bill | CHKD | Lord | MATL: | Jimmy | TOLERANCE | Sam | DATE | 14.03.2009 |
| APPD: | Louis | | | FINISH | Georg | | | Sheet No. | 3 from 3 |

Customer: