

# EDCON-COMPONENTS

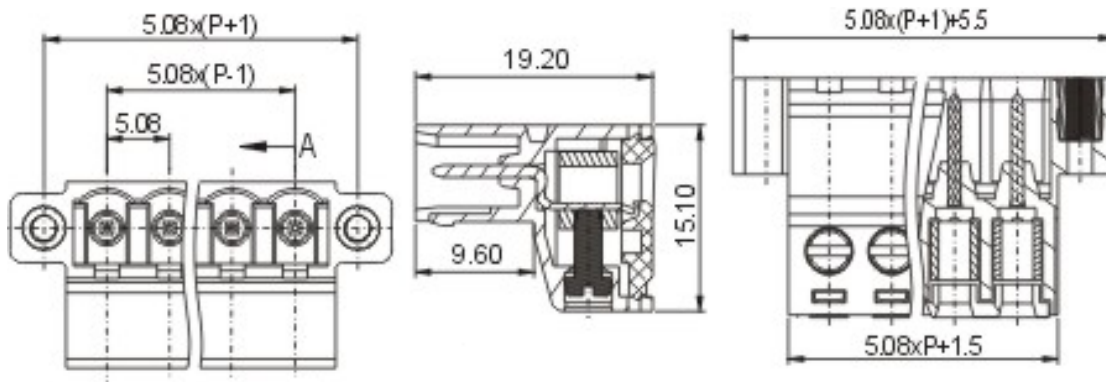

## Drawing



## P.C.B. Layout

## Specification

APPROVAL	ULus	CE
<b>Electrical</b>		
Standard	UL	IEC
Rated voltage	300V	320V
Rated current	15A	20A
Wire range	28-12 AWG	2.5mm <sup>2</sup>
Withstanding voltage	AC 2500V/1min	
<b>Mechanical</b>		
Ambient temperature	-40°C ~ +105°C	
Torque	M2.5, 0.4Nm (3.5Lb-In.)	
Strip length	7mm	
<b>Dimensions</b>		
Pitch	5.08mm	
Poles	2P - 22P	2P - 12P
<b>Material</b>		
Housing	PA66 (UL94V-0)	
Contact	Copper	
Cage	Brass, Ni plated	
Nut	M2.5, Brass	



## Certification



Pluggable Terminal Block /  
Pitch 5.08mm

Part No.: A14M097

Customer:

DRW:	Bill	CHKD	Lord	MATL:	Jimmy	TOLERANCE	Sam	DATE	14.3.2009
APPD:	Louis			FINISH	Georg		Sheet No.		1 from 3

[www.edcon-components.com](http://www.edcon-components.com)

email: [info@edcon-components.com](mailto:info@edcon-components.com)

# EDCON-COMPONENTS



## Ordering Informations

Serie	-	No. of Pole	Body-Color	-	Customer Request
<b>A14M097</b>	-	<b>XX</b>	<b>XX</b>	-	<b>X</b>

XX = total	<b>WH</b> - white
02	<b>GN</b> - green
...	<b>GR</b> - gray
22	<b>LG</b> - light gray
	<b>PG</b> - Phoenix Green
	<b>OR</b> - orange
	<b>BL</b> - blue
	<b>BK</b> - black



**Certification**



Pluggable Terminal Block /  
Pitch 5.08mm

Part No.: A14M097

Customer:

DRW:	Bill	CHKD	Lord	MATL:	Jimmy	TOLERANCE	Sam	DATE	14.3.2009
APPD:	Louis			FINISH	Georg			Sheet No.	2 from 3

[www.edcon-components.com](http://www.edcon-components.com)

email: [info@edcon-components.com](mailto:info@edcon-components.com)

# EDCON-COMPONENTS



## Soldering - Profil

### Classification Reflow Profile (JEDEC J-STD-020C)



Pluggable Terminal Block /  
Pitch 5.08mm

Part No.: A14M097

Customer:

DRW:	Bill	CHKD	Lord	MATL:	Jimmy	TOLERANCE	Sam	DATE	14.3.2009
APPD:	Louis			FINISH	Georg		Sheet No.	3 from 3	

[www.edcon-components.com](http://www.edcon-components.com)

email: [info@edcon-components.com](mailto:info@edcon-components.com)