

EDCON-COMPONENTS

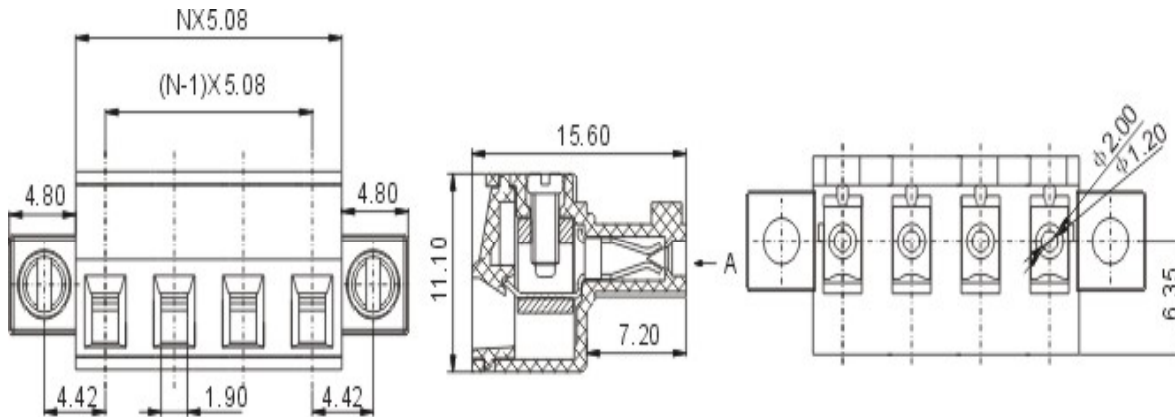

Drawing



P.C.B. Layout

Specification

APPROVAL



Electrical

Standard
Rated voltage
Rated current
Wire range
Withstanding voltage

UL	IEC
300V	250V
8A	7A
28-16 AWG	0.5 - 1.5mm ²
AC 2000V/1min	

Mechanical

Ambient temperature
Strip length
Screw, Torque

-40°C ~ +105°C
7mm
M2, 0.2Nm (1.7Lb-In.)

Dimensions

Pitch
Poles

5.08mm
2P - 12P

Material

Housing
Contact
Cage
Terminal screw

PA66 (UL94V-0)
Phosphor Bronze
Brass, Ni plated
steel, Cr³⁺ Zn plated



Certification

**Pluggable Terminal Block /
Pitch 5.08mm w. flange**

Part No.: A14M047

Customer:

DRW:	Bill	CHKD	Lord	MATL:	Jimmy	TOLERANCE	Sam	DATE	13.03.2017
APPD:	Louis			FINISH	Georg		Sheet No.	1 from 3	



EDCON-COMPONENTS



Ordering Informations

Serie	No. of Pos.	Body Color	Screw Type	Approval Code	ROHS	Packing	EDCON Cust. No.	Customer Version		
-------	-------------	------------	------------	---------------	------	---------	-----------------	------------------	--	--

A14M047	02	PG	A	N	R	B				
----------------	-----------	-----------	----------	----------	----------	----------	--	--	--	--

02= Number of Pos. Standard 2 ~ 24Pos.	PG= Phoenix Green (Standard) WH= White GN= Green GY= Gray LG= Light Gray OR= Orange BL= Blue BK= Black	A= Slotted Screw Type (Standard)  B= Cross Slotted Screw Type  C= Screwless Type	N= NON Approval A= UL /UR Approval Please consult EDCON for available B= VDE Approval Please consult EDCON for available C= TÜV Approval Please consult EDCON for available	R= ROHS Conform N= NON ROHS Conform	B= Bulk-Ware I= Individual Package	xxxxxx= Customer Number	xxx= Customer Version ??(Printing)
--	---	--	--	--	---	--------------------------------	--



Certification

Pluggable Terminal Block / Pitch 5.08mm w. flange

Part No.: A14M047

Customer:

DRW:	Bill	CHKD	Lord	MATL:	Jimmy	TOLERANCE	Sam	DATE	13.03.2017
APPD:	Louis			FINISH	Georg			Sheet No.	2 from 3



Soldering - Profil

Classification Reflow Profile (JEDEC J-STD-020C)

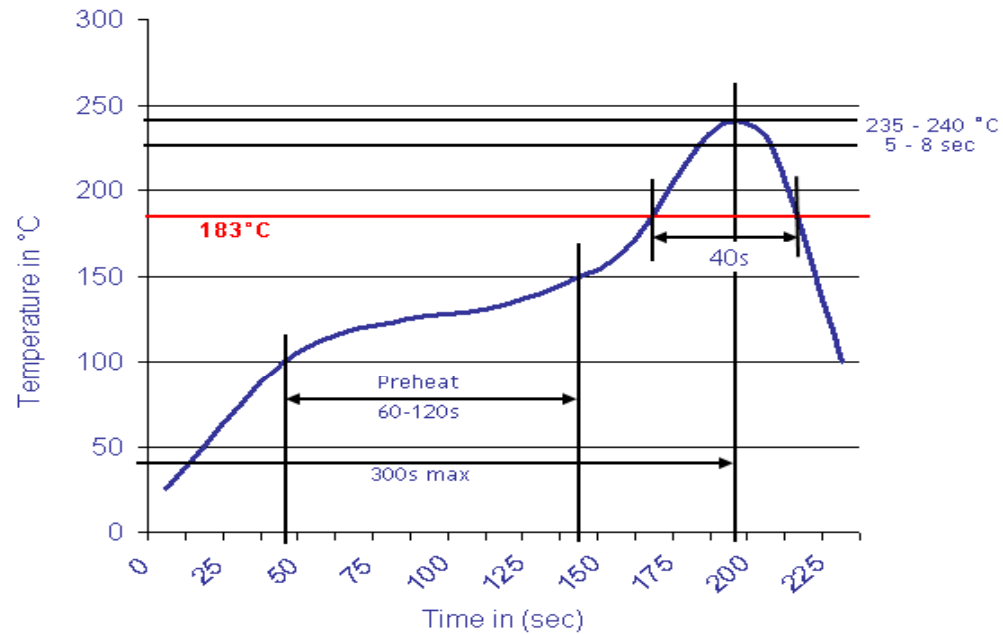

**Pluggable Terminal Block /
Pitch 5.08mm w. flange**

Part No.: A14M047

Customer:

DRW:	Bill	CHKD	Lord	MATL:	Jimmy	TOLERANCE	Sam	DATE	13.03.2017
APPD:	Louis			FINISH	Georg		Sheet No.	3 from 3	