

EDCON-COMPONENTS

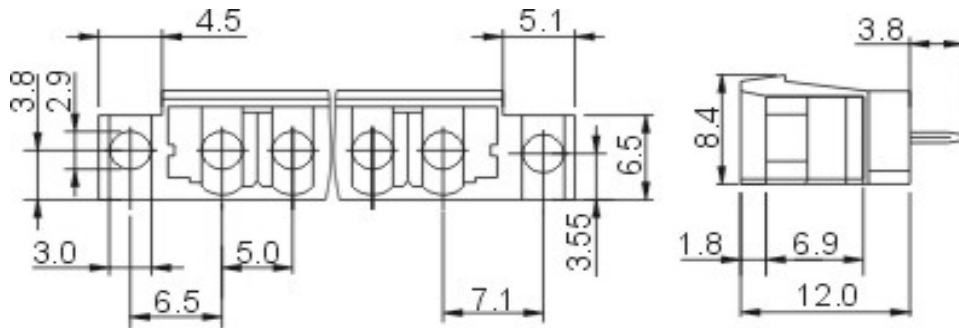

Drawing



Specification

Electrical

Standard	UL	IEC
Rated voltage	300V	320V, 400V
Rated current	15A	20A
Withstanding voltage	AC 2500V/1min	

Mechanical

Ambient temperature	-40°C ~ +105°C
---------------------	----------------

Dimensions

Pitch	5.00mm
Poles	2P - 24P 2P - 12P

Material

Housing	PA66 (UL94V-0)
Pin header	Brass, Tin plated

P.C.B. Layout

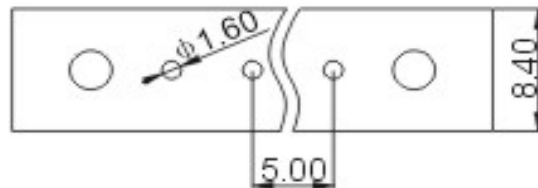

Pluggable Terminal Block /
Pitch 5.00mm

Part No.: A14L042

Customer:

DRW:	Bill	CHKD	Lord	MATL:	Jimmy	TOLERANCE	Sam	DATE	14.3.2009
APPD:	Louis			FINISH	Georg			Sheet No.	1 from 3

www.edcon-components.com

email: info@edcon-components.com

EDCON-COMPONENTS

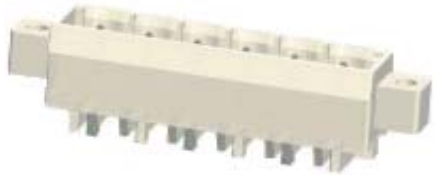

Ordering Informations

Serie	-	No. of Pole	Body-Color	-	Customer Request
A14L042	-	XX	XX	-	X

XX = total	WH - white
02	GN - green
...	GR - gray
24	LG - light gray
	PG - Phoenix Green
	OR - orange
	BL - blue
	BK - black



Pluggable Terminal Block /
Pitch 5.00mm

Part No.: A14L042

Customer:

DRW:	Bill	CHKD	Lord	MATL:	Jimmy	TOLERANCE	Sam	DATE	14.3.2009
APPD:	Louis			FINISH	Georg			Sheet No.	2 from 3

www.edcon-components.com

email: info@edcon-components.com

EDCON-COMPONENTS



Soldering - Profil

Classification Reflow Profile (JEDEC J-STD-020C)



Pluggable Terminal Block /
Pitch 5.00mm

Part No.: A14L042

Customer:

DRW:	Bill	CHKD	Lord	MATL:	Jimmy	TOLERANCE	Sam	DATE	14.3.2009
APPD:	Louis			FINISH	Georg		Sheet No.	3 from 3	

www.edcon-components.com

email: info@edcon-components.com