

# Data Sheet

## Pluggable Terminal Block

**Pitch: 5,00 mm**

**Serie: A14L022**

### Customer Information for special Item

**EDCON Customer : 0**

**Customer Version No. : 0**

# EDCON-COMPONENTS

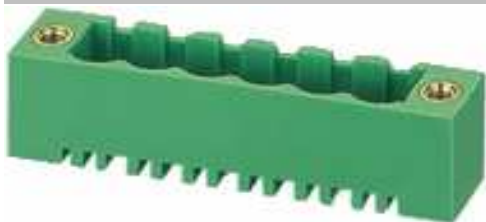

## Technical Discription

## Drawing (Dimension in mm)

### Electrical

Standard	UL	IEC
Rated voltage	300V	320V, 400V
Rated current	15A	20A
Withstanding voltage	AC 2500V/1min	

### Mechanical

Ambient temperature	-40°C ~ +105°C
---------------------	----------------

### Dimensions

Pitch	5.00mm
Poles	2P - 22P   2P - 12P

### Material

Housing	PA66 (UL94V-0)
Pin header	Brass, Tin plated
Nut	M2.5, Brass

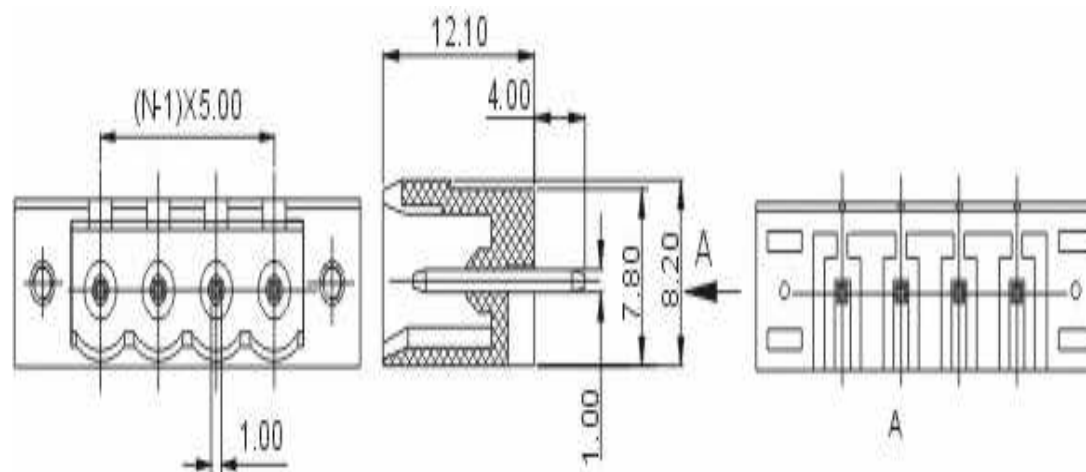

### Pluggable Terminal Block

Part No.: **A14L022**

Customer:

DRW:	Jason	CHKD	Wilson	MATL:	Wilson	TOLERANCE	Mason	DATE	26.05.2014
APPD:	Schumi			FINISH	Jamy		Sheet No.	1 from 4	

# EDCON-COMPONENTS



PCB Layout (Dimension in mm)

Dimensions (mm)

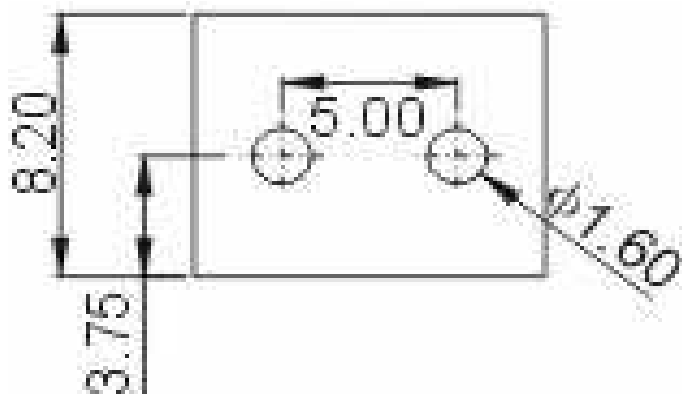

**Pluggable Terminal Block**

Part No.: **A14L022**

DRW:	Jason	CHKD	Wilson	MATL:	Wilson	TOLERANCE	Mason	DATE	26.05.2014
APPD:	Schumi			FINISH	Jamy		Sheet No.	2 from 4	Customer:

[www.edcon-components.com](http://www.edcon-components.com)

email: [info@edcon-components.com](mailto:info@edcon-components.com)

# EDCON-COMPONENTS



## Ordering Informations

Serie	No. of Pos.	Body Color	Approval	Approval Code	ROHS	Packing	EDCON Cust. No.	Customer Version		
-------	-------------	------------	----------	---------------	------	---------	-----------------	------------------	--	--

<b>A14L022</b>	<b>02</b>	<b>GN</b>	<b>N</b>	<b>N</b>	<b>R</b>	<b>B</b>				
----------------	-----------	-----------	----------	----------	----------	----------	--	--	--	--

Pitch 5,00	<b>02</b> = Number of Pos. Standard 2 ~ 24Pos.	<b>GY</b> = Gray (Standard)  <b>GN</b> = Green  <b>OR</b> = Orange  <b>BK</b> = Black	<b>N</b> = No Approval  <b>1</b> = Approval for Material  <b>2</b> = Approval for Terminal Block	<b>N</b> = NON Approval  <b>A</b> = UL /UR Approval Please consult EDCON for available  <b>B</b> = VDE Approval Please consult EDCON for available  <b>C</b> = TÜV Approval Please consult EDCON for available	<b>R</b> = ROHS Conform  <b>N</b> = NON ROHS Conform	<b>B</b> = Standard Package  <b>I</b> = Individual Package	<b>xxxxxx</b> = Customer Number	<b>xxx</b> = Customer Version ??(Printing)		
---------------	---	---	--	--	--	--	---------------------------------	--	--	--

**Pluggable Terminal Block**

Part No.: **A14L022**

DRW:	Jason	CHKD	Wilson	MATL:	Wilson	TOLERANCE	Mason	DATE	26.05.2014
APPD:	Schumi			FINISH	Jamy		Sheet No.		3 from 4

Customer:



Soldering Profile Curve

Classification Reflow Profile (JEDEC J-STD-020C)



**Pluggable Terminal Block**

Part No.: **A14L022**

Customer:

DRW:	Jason	CHKD	Wilson	MATL:	Wilson	TOLERANCE	Mason	DATE	26.05.2014
APPD:	Schumi			FINISH	Jamy		Sheet No.	4 from 4	