

EDCON-COMPONENTS

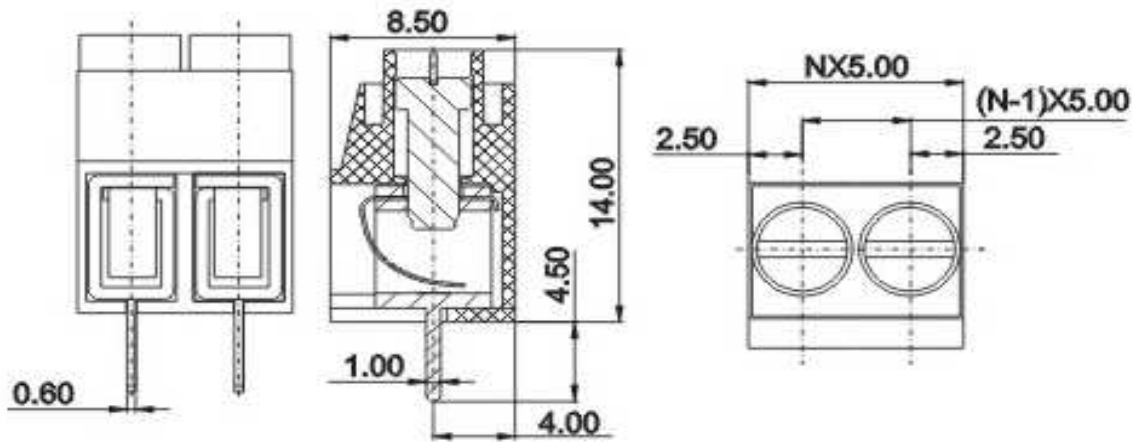

Drawing



P.C.B. Layout

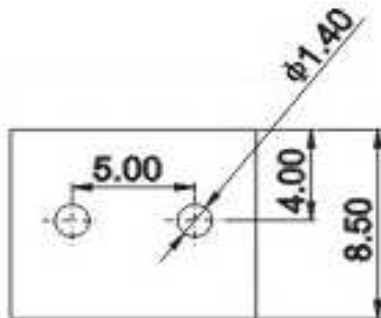

Specification

APPROVAL



Electrical

Standard
Rated voltage
Rated current
Wire range
Withstanding voltage

UL	IEC
300V	250V, 450V
15A	22A
22-12 AWG	0.5-2.5mm ²
AC2000V/1Min	

Mechanical

Ambient temperature
Strip length
Screw, Torque

-40°C ~ +105°C
6 ~ 7mm
M3, 0.4Nm (3.5Lb-In.)

Dimensions

Pitch
Poles

5.00mm
2P, 3P-24P

Material

Housing
Pin header
Screw
Wire guard

PA66 (UL94V-0)
Brass, Tin plated
steel, Cr³⁺ Zn plated
Phosphor Bronze



Certification



Wire Protector Terminal Block /
Pitch 5.00mm

Part No.: A12L021

Customer:

DRW:	Bill	CHKD	Lord	MATL:	Jimmy	TOLERANCE	Sam	DATE	14.03.2009
APPD:	Louis			FINISH	Georg			Sheet No.	1 from 3

www.edcon-components.com

email: info@edcon-components.com

Copyright by EDCON-COMPONENTS

EDCON-COMPONENTS



Ordering Informations

Serie	-	No. of Pole	Body-Color	wire protector	Screw	-	Customer Request
A12L021	-	XX	XX	X	X	-	X

XX = total	WH - white	1 - with wire protector	A - Slotted screw (standard)
	GN - green	2 - without wire protector	B - Cross-slotted screw
	GR - gray		
	BL - blue		



PG - Phoenix Green
OR - orange
LG - light gray
BK - black



wire protector

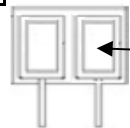

without wire protector



Certification



Wire Protector Terminal Block /
Pitch 5.00mm

Part No.: A12L021

Customer:

DRW:	Bill	CHKD	Lord	MATL:	Jimmy	TOLERANCE	Sam	DATE	14.03.2009
APPD:	Louis			FINISH	Georg			Sheet No.	2 from 3

www.edcon-components.com

email: info@edcon-components.com



Soldering - Profil

Classification Reflow Profile (JEDEC J-STD-020C)

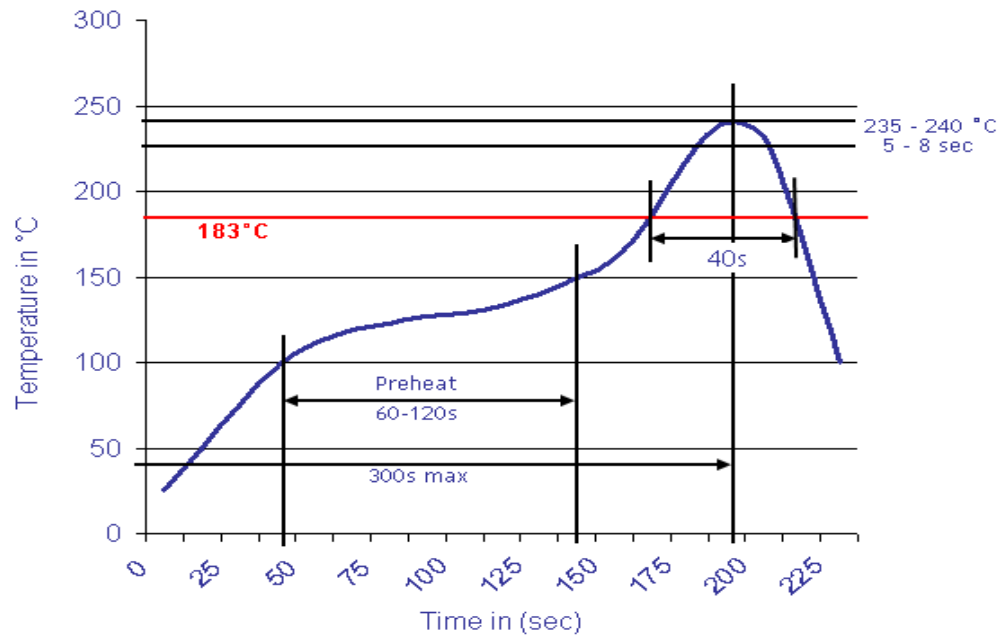

Wire Protector Terminal Block /
Pitch 5.00mm

Part No.: A12L021

DRW:	Bill	CHKD	Lord	MATL:	Jimmy	TOLERANCE	Sam	DATE	14.03.2009
APPD:	Louis			FINISH	Georg			Sheet No.	3 from 3

Customer: