

# EDCON-COMPONENTS



## Technical Dimensions (mm)

- A 29,0mm +/-1mm
- B 33,0mm +/-1mm
- C 15,0mm +/-1mm
- D 15,5mm +/-1mm
- E 21,5mm +/-1mm

## Applicable Diameter

15mm (max.)

## Application

Enclosures for Channel-type EMI suppressor snapes  
 Internal and external power cables  
 Internal cables between PC boards and data connectors

## Drawing

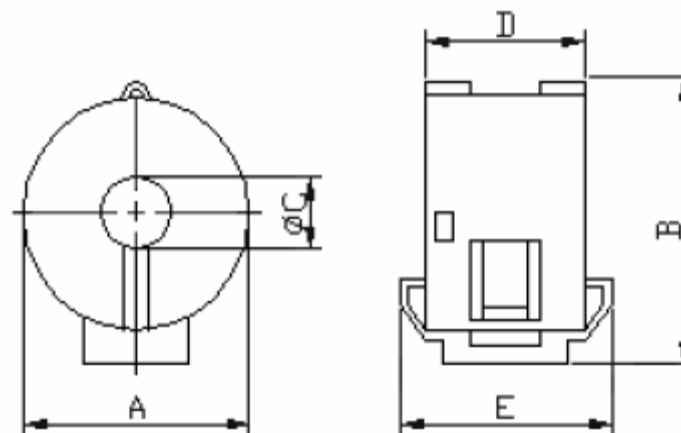

## Round Split Core Ferrit

Serie No.: **G25016**

Customer:

DRW:	Jason	CHKD	Wilson	MATL:	Wilson	TOLERANCE	Mason	DATE	02.05.2010
APPD:	Schumi			FINISH	Jamy		Sheet No.	1 from 2	

[www.edcon-components.com](http://www.edcon-components.com)

email: [info@edcon-components.com](mailto:info@edcon-components.com)



## Impedance Specification Curve

### Ordering Information

Serie	Material	ROHS	Packing
G25016	K5B	R	BX101
		R= ROHS Conform N= NON ROHS Conform	BX101= BoX 100 PCS IDxxx= Individual PCS

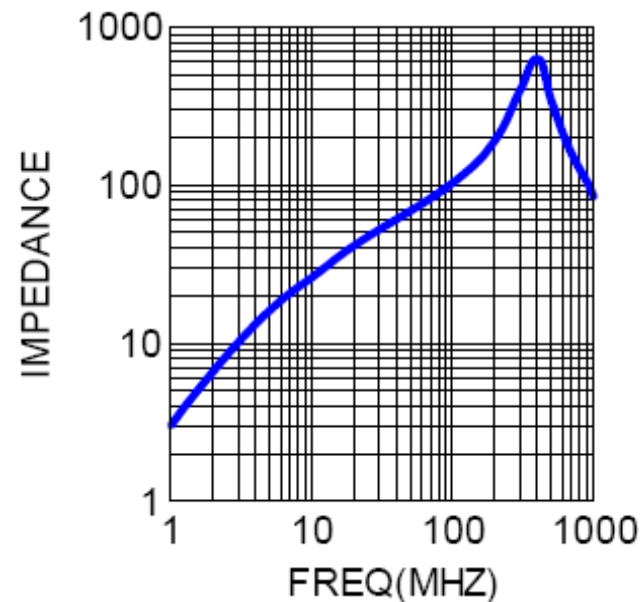

**Round Split Core Ferrit**

Serie No.: **G25016**

Customer:

DRW:	Jason	CHKD	Wilson	MATL:	Wilson	TOLERANCE	Mason	DATE	02.05.2010
APPD:	Schumi			FINISH	Jamy		Sheet No.	2 from 2	