

# EDCON-COMPONENTS



## Technical Dimensions (mm)

- A 28,0mm +/-1mm
- B 31,5mm +/-1mm
- C 11,5mm +/-1mm
- D 18,0mm +/-1mm
- E 24,0mm +/-1mm

## Applicable Diameter

11,5mm (max.)

## Application

Enclosures for Channel-type EMI suppressor snapes  
 Internal and external power cables  
 Internal cables between PC boards and data connectors

## Drawing

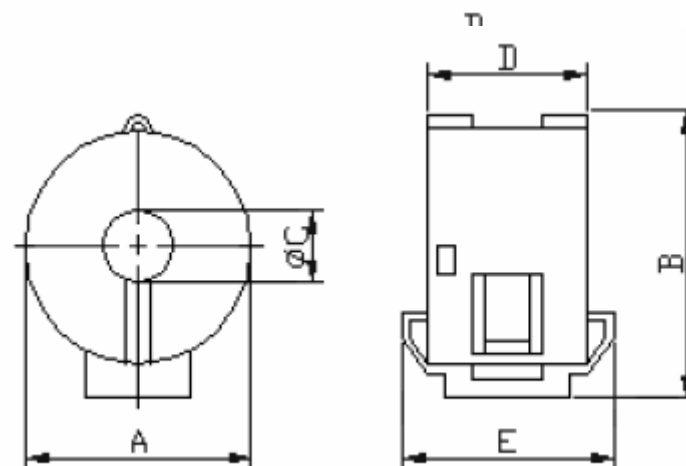

## Round Split Core Ferrit

Serie No.: **G25015**

Customer:

|       |        |      |        |        |        |           |           |          |            |
|-------|--------|------|--------|--------|--------|-----------|-----------|----------|------------|
| DRW:  | Jason  | CHKD | Wilson | MATL:  | Wilson | TOLERANCE | Mason     | DATE     | 02.05.2010 |
| APPD: | Schumi |      |        | FINISH | Jamy   |           | Sheet No. | 1 from 2 |            |

# EDCON-COMPONENTS



## Impedance Specification Curve

### Ordering Information

| Serie  | Material | ROHS                                   | Packing                                     |
|--------|----------|--|---|
| G25015 | K5B      | R                                      | BX101                                       |
|        |          | R= ROHS Conform<br>N= NON ROHS Conform | BX101= BoX 100 PCS<br>IDxxx= Individual PCS |

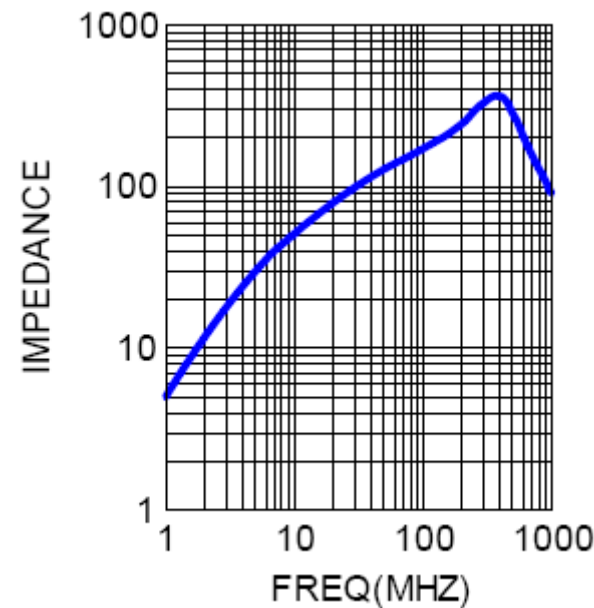

**Round Split Core Ferrit**

Serie No.: **G25015**

Customer:

|       |        |      |        |        |        |           |           |          |            |
|-------|--------|------|--------|--------|--------|-----------|-----------|----------|------------|
| DRW:  | Jason  | CHKD | Wilson | MATL:  | Wilson | TOLERANCE | Mason     | DATE     | 02.05.2010 |
| APPD: | Schumi |      |        | FINISH | Jamy   |           | Sheet No. | 2 from 2 |            |