

EDCON-COMPONENTS

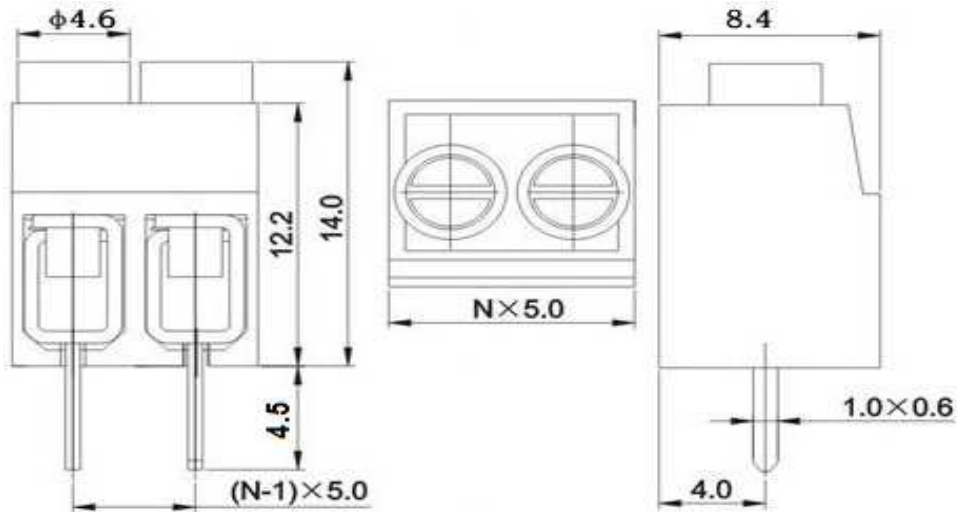

Drawing



P.C.B. Layout

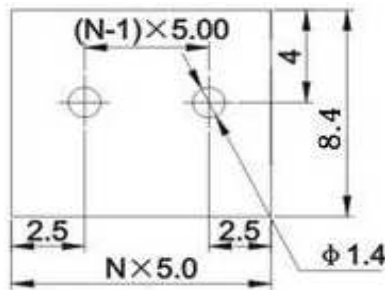

Specification

Electrical

Rated voltage	300V
Rated current	15A
Wire range	22-12AWG / 2.5mm ²
Contact resistance	20mΩ
Withstanding voltage	AC 1500V/1Min
Insulation resistance	5000MΩ/DC1000V

Mechanical

Ambient temperature	-40°C ~ +105°C
Strip length	6 ~ 7mm
Screw, Torque	M2.5, 0.4Nm (3.6Lb-In.)

Dimensions

Pitch	10.00mm
Poles	2P - 24P

Material

Housing	PA66 (UL94V-0)
Pin header	Brass, Tin-plated
Screw	steel, Zinc-plated
Wire guard	Phosphor Bronze, Ni-plated



Wire Protector Terminal Block /
Pitch 10.00mm

Part No.: A12T013

Customer:

DRW:	Bill	CHKD	Lord	MATL:	Jimmy	TOLERANCE	Sam	DATE	14.03.2009
APPD:	Louis			FINISH	Georg		Sheet No.		1 from 3

www.edcon-components.com

email: info@edcon-components.com

EDCON-COMPONENTS



Ordering Informations

Serie	-	No. of Pole	Body-Color	wire protector	Screw	-	Customer Request
A12T013	-	XX	XX	X	X	-	X

XX = total	WH - white	1 - with wire protector	A - Slotted screw (<i>standard</i>)
02P	GN - green	2 - without wire protector	B - Cross-slotted screw
...	GR - gray		
24P	LG - light gray		



PG - Phoenix Green
OR - orange
BL - blue
BK - black



wire protector

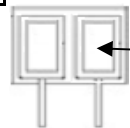

without wire protector



Wire Protector Terminal Block /
Pitch 10.00mm

Part No.: A12T013

Customer:

DRW:	Bill	CHKD	Lord	MATL:	Jimmy	TOLERANCE	Sam	DATE	14.03.2009
APPD:	Louis			FINISH	Georg			Sheet No.	2 from 3

www.edcon-components.com

email: info@edcon-components.com

EDCON-COMPONENTS



Soldering - Profil

Classification Reflow Profile (JEDEC J-STD-020C)



Wire Protector Terminal Block /
Pitch 10.00mm

Part No.: A12T013

Customer:

DRW:	Bill	CHKD	Lord	MATL:	Jimmy	TOLERANCE	Sam	DATE	14.03.2009
APPD:	Louis			FINISH	Georg		Sheet No.	3 from 3	

www.edcon-components.com

email: info@edcon-components.com