

# EDCON-COMPONENTS

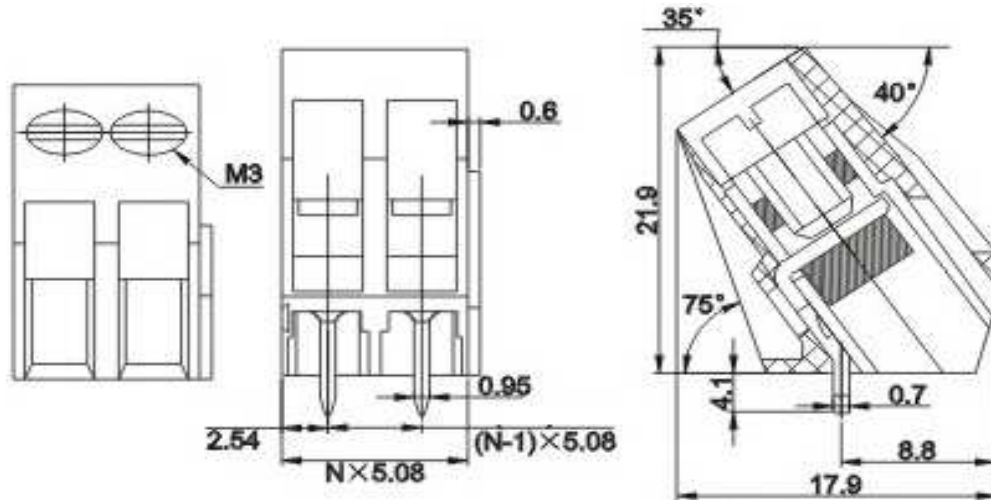

## Drawing



## P.C.B. Layout

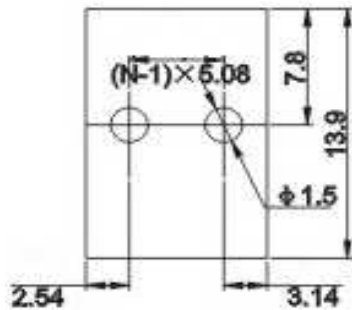

## Specification

### Electrical

Rated voltage	300V
Rated current	15A
Wire range	22-14 AWG / 2.5mm <sup>2</sup>
Contact resistance	20mΩ
Withstanding voltage	AC 1500V/1Min
Insulation resistance	5000MΩ/DC1000V

### Mechanical

Ambient temperature	-40°C ~ +105°C
Strip length	6 ~ 7mm
Screw, Torque	M3, 0.5Nm (4.5Lb-In.)

### Dimensions

Pitch	5.08mm
Poles	

### Material

Housing	PA66 (UL94V-0)
Pin header	Brass, Tin-plated
Screw	steel, Zinc-plated
Wire guard	Phosphor Bronze, Ni-plated



Wire Protector Terminal Block /  
Pitch 5.08mm

Part No.: A12M006

Customer:

DRW:	Bill	CHKD	Lord	MATL:	Jimmy	TOLERANCE	Sam	DATE	14.03.2009
APPD:	Louis			FINISH	Georg		Sheet No.	1 from 3	

[www.edcon-components.com](http://www.edcon-components.com)

email: [info@edcon-components.com](mailto:info@edcon-components.com)

Copyright by EDCON-COMPONENTS

# EDCON-COMPONENTS



## Ordering Informations

Serie	-	No. of Pole	Body-Color	wire protector	Screw	-	Customer Request
A12M006	-	XX	XX	X	X	-	X

XX = total	WH - white	1 - with wire protector	A - Slotted screw (standard)
	GN - green	2 - without wire protector	B - Cross-slotted screw
	GR - gray		
	LG - light gray		



PG - Phoenix Green
OR - orange
BL - blue
BK - black



wire protector

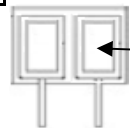

without wire protector



Wire Protector Terminal Block /  
Pitch 5.08mm

Part No.: A12M006

Customer:

DRW:	Bill	CHKD	Lord	MATL:	Jimmy	TOLERANCE	Sam	DATE	14.03.2009
APPD:	Louis			FINISH	Georg		Sheet No.		2 from 3

[www.edcon-components.com](http://www.edcon-components.com)

email: [info@edcon-components.com](mailto:info@edcon-components.com)



## Soldering - Profil

### Classification Reflow Profile (JEDEC J-STD-020C)

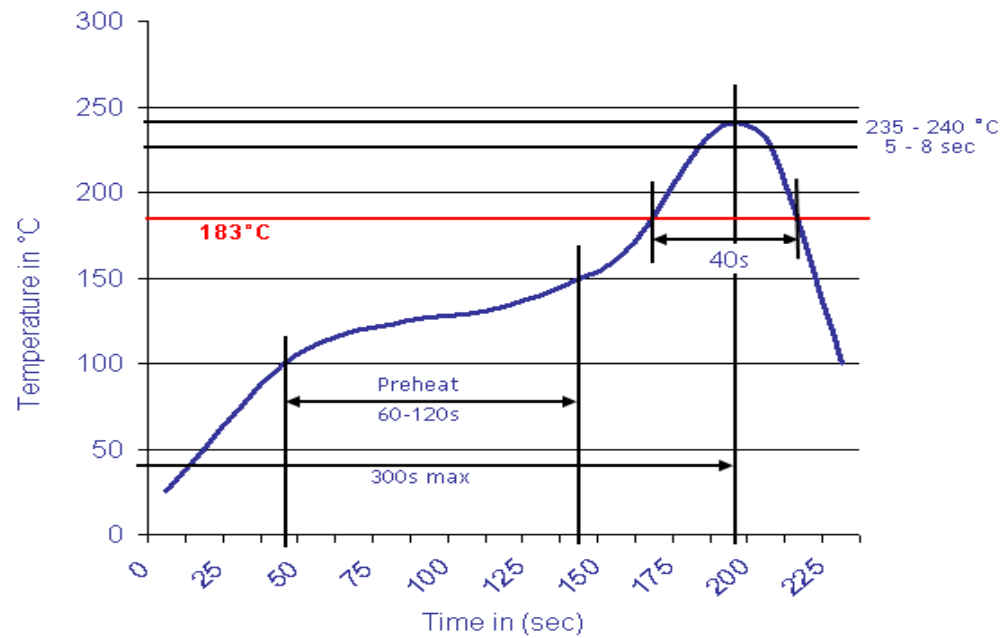

Wire Protector Terminal Block /  
Pitch 5.08mm

Part No.: A12M006

Customer:

DRW:	Bill	CHKD	Lord	MATL:	Jimmy	TOLERANCE	Sam	DATE	14.03.2009
APPD:	Louis			FINISH	Georg		Sheet No.		3 from 3