

EDCON-COMPONENTS

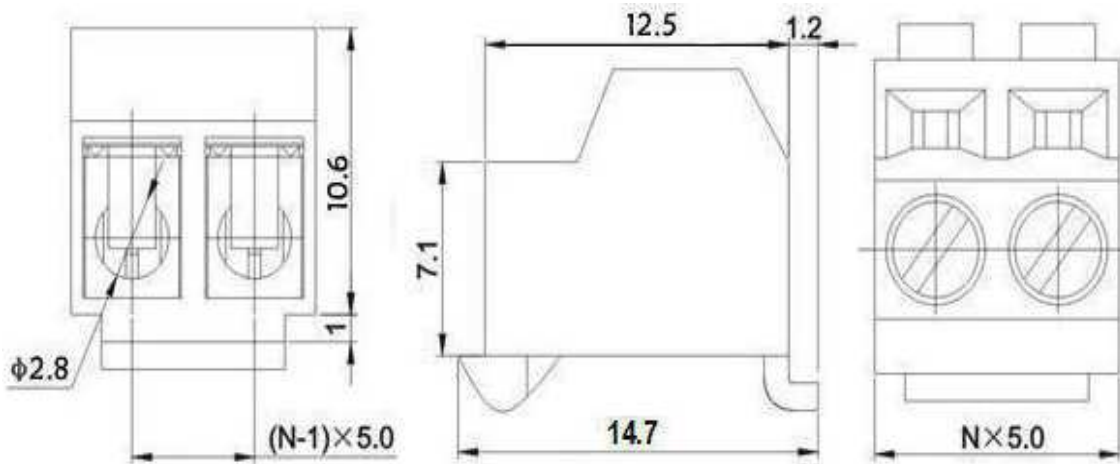

Drawing



P.C.B. Layout

Specification

Electrical

Standard	
Rated voltage	AC 300V
Rated current	10A
Wire range	22-14 AWG / 2.5mm ²
Contact resistance	20mΩ
Insulation resistance	5000MΩ/DC1000V
Withstand voltage	AC2000V/1Min

Mechanical

Ambient temperature	-30°C ~ +120°C
Screw, Torque	M3, 0.5Nm (4.5Lb-In.)
Strip Length	4.5 ~ 5mm

Dimensions

Pitch	5.00mm
Poles	

Material

Housing	PBT (UL94V-0)
Pin header	Brass, Tin-plated
Screw	steel, Zinc-plated
Wire guard	Stainless steel



Wire Protector Terminal Block /
Pitch 5.00mm

Part No.: A12L056

Customer:

DRW:	Bill	CHKD	Lord	MATL:	Jimmy	TOLERANCE	Sam	DATE	14.03.2009
APPD:	Louis			FINISH	Georg		Sheet No.		1 from 3

www.edcon-components.com

email: info@edcon-components.com

EDCON-COMPONENTS



Ordering Informations

Serie	-	No. of Pole	Body-Color	wire protector	Screw	-	Customer Request
A12L056	-	XX	XX	X	X	-	X

XX = total	WH - white	1 - with wire protector	A - Slotted screw (standard)
	GN - green	2 - without wire protector	B - Cross-slotted screw
	GR - gray		
	LG - light gray		
	PG - Phoenix Green		

OR - orange
BL - blue
BK - black



wire protector

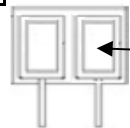

without wire protector



Wire Protector Terminal Block /
Pitch 5.00mm

Part No.: A12L056

Customer:

DRW:	Bill	CHKD	Lord	MATL:	Jimmy	TOLERANCE	Sam	DATE	14.03.2009
APPD:	Louis			FINISH	Georg		Sheet No.		2 from 3

www.edcon-components.com

email: info@edcon-components.com



Soldering - Profil

Classification Reflow Profile (JEDEC J-STD-020C)



Wire Protector Terminal Block /
Pitch 5.00mm

Part No.: A12L056

DRW:	Bill	CHKD	Lord	MATL:	Jimmy	TOLERANCE	Sam	DATE	14.03.2009
APPD:	Louis			FINISH	Georg		Sheet No.	3 from 3	

Customer: