

EDCON-COMPONENTS



Specifications

Features

Contact Positions: 09, 15, 25, 37

Materials

Contact Brass and Phosphor Bronze
Housing: PBT +30% Glass Fiber (UL 94V-0)
Shell: cold roller steel

Electrical Characteristics

Current Rating: 3Ampere
Withstanding Voltage: AC 1000V r.m.s.
Insulation Resistance: 3000 Megaohms Minimum at DC500V
Contact Resistance: 15 Milliohm Maximum
Operation Temperature: -55°C ~ +105°C

Mechanical Characteristics:

Contact Resistance Force: 341gr. Maximum
Contact Separation Force: 20gr. Minimum

Finishes:

Contact Plating (look Order Code)
Shell Plating (look order code)

Dimensions (mm)

Male Contact

Pos.	9	15	25	37
Dim.A	16,92	25,25	35,90	55,42
Dim.B	25,00	33,30	47,10	63,50
Dim.C	30,80	39,20	53,10	69,40
Dim.D	19,20	27,70	41,10	57,30

Female Contact

Pos.	9	15	25	37
Dim.A	16,30	24,60	38,30	54,80
Dim.B	25,00	33,30	47,10	63,50
Dim.C	30,80	39,20	53,10	69,40
Dim.D	19,20	27,70	41,10	57,30

P.C.B. Layout

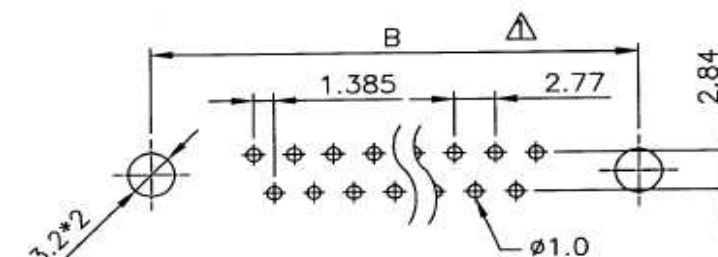

RECOMMENDED P.C.B. LAYOUT (TOP VIEW)
TOLERANCES: ±0.05mm

**D-Sub Connector Wire Wrap
Machined Contact**

Part No.: **T24F900**

Customer:

DRW:	Jason	CHKD	Wilson	MATL:	Wilson	TOLERANCE	Mason	DATE	10.04.2009
APPD:	Schumi			FINISH	Jamy		Sheet No.	1 from 4	

www.edcon-components.com

email: info@edcon-components.com

EDCON-COMPONENTS



Female Contact

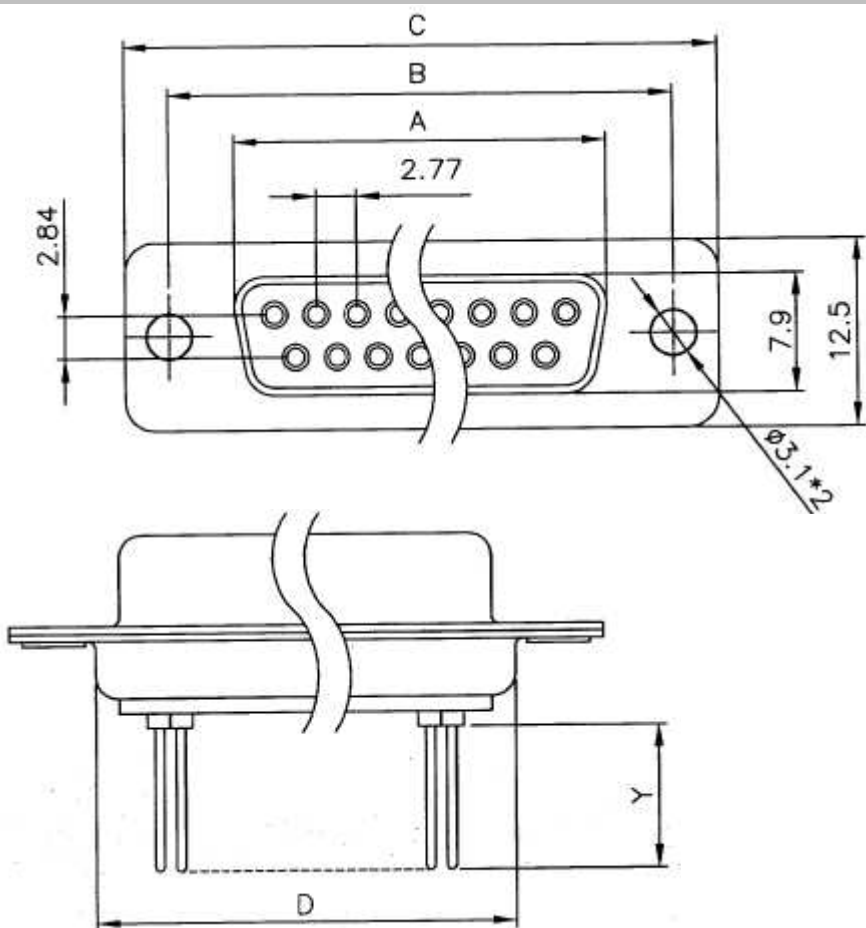

Male Contact

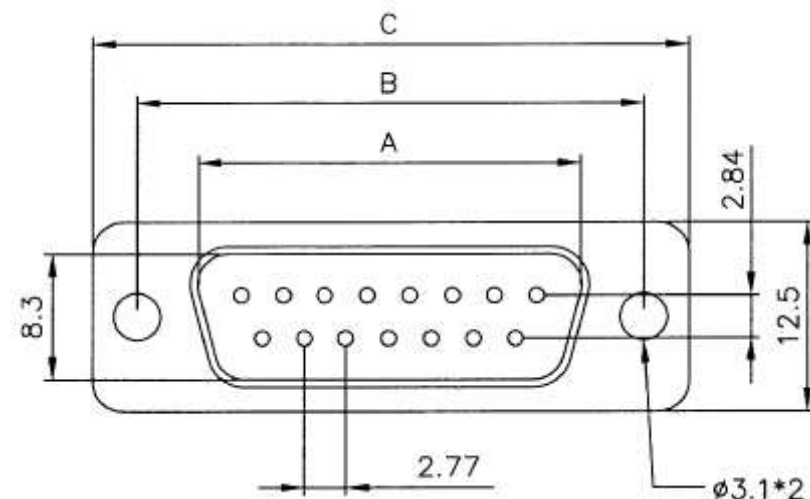

**D-Sub Connector Wire Wrap
Machined Contact**

Part No.: **T24F900**

DRW:	Jason	CHKD	Wilson	MATL:	Wilson	TOLERANCE	Mason	DATE	10.04.2009
APPD:	Schumi			FINISH	Jamy		Sheet No.	2 from 4	Customer:

www.edcon-components.com

email: info@edcon-components.com

EDCON-COMPONENTS



Ordering Informations

Serie	No. of contacts.	Contact Type	Shell Finish	PCB Options	Screw	Wire Wrap length	Contact Plating	Plastic Color	ROHS	Packing
T24F900	09	F	T	A	0	0	GF	BK	R	TY

09= Contacts	F= Female	N= Nickel	A= Through Hole	1= without mounting screw	A= Y=9,50mm	GF= Gold Flash	BK= Black	R= ROHS Conform	TY= Tray Packing				
09, 15, 25, 37 Contacts	M= Male	T= Tin	B= Thread Insert UNC-40			2= Mounted screw 5,0x10mm	B= Y=13,0mm			GA= 5µ Gold	WH= White	N= NON ROHS Conform	BU= Bulk-Ware
										GB= 10µ Gold	BL= Blue		
				3= added screw separately		GC= 15µ Gold	GY= Gray						
						GD= 30µ Gold							
						SF= Selective Gold flash							
						SA= 5µ Selective Gold flash							
						SB= 10µ Selective Gold flash							
						SC= 15µ Selective Gold flash	SD= 30µ Selective Gold flash						

D-Sub Connector Wire Wrap Machined Contact	
Part No.:	T24F900

DRW:	Jason	CHKD	Wilson	MATL:	Wilson	TOLERANCE	Mason	DATE	10.04.2009	Customer:
APPD:	Schumi			FINISH	Jamy			Sheet No.	3 from 4	



Soldering Profile Curve

Classification Reflow Profile (JEDEC J-STD-020C)

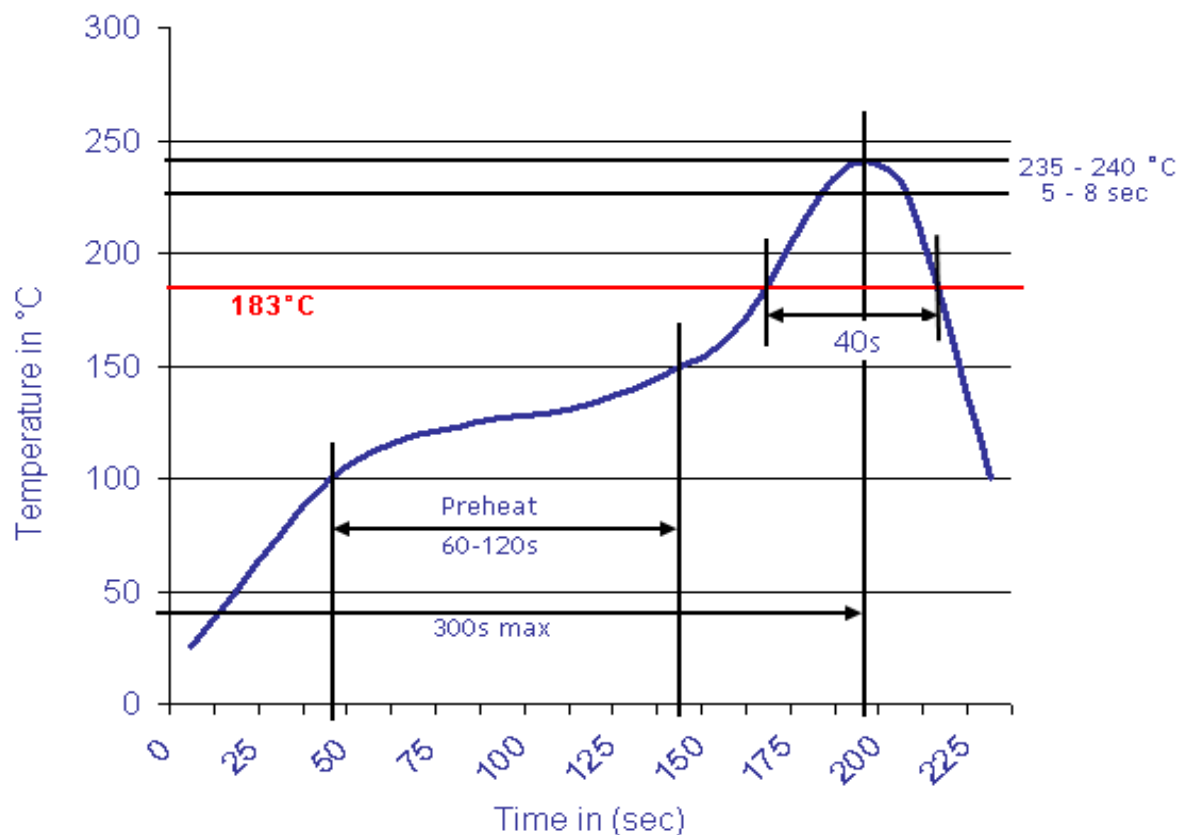

D-Sub Connector Wire Wrap Machined Contact	
Part No.:	T24F900
Customer:	

DRW:	Jason	CHKD	Wilson	MATL:	Wilson	TOLERANCE	Mason	DATE	10.04.2009
APPD:	Schumi			FINISH	Jamy		Sheet No.	4 from 4	