

EDCON-COMPONENTS

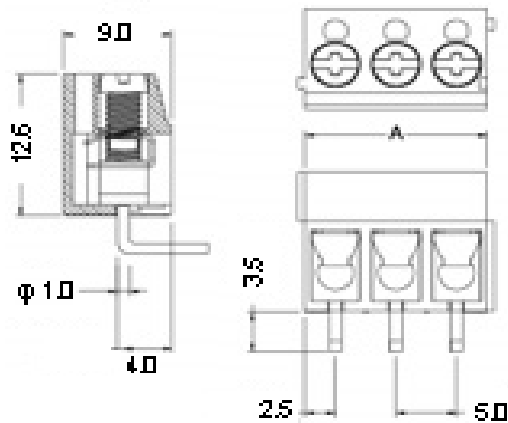

Drawing



P.C.B. Layout

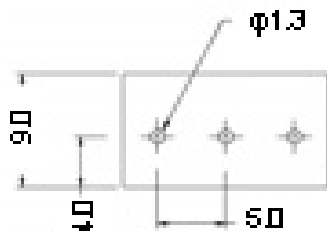

| A [mm] | |
|--------|------|
| 2P | 10.0 |
| 3P | 15.0 |

Specification

Electrical

| | |
|---------------|-----------|
| Rated voltage | AC 300V |
| Rated current | 16A |
| Wire range | 22-14 AWG |

Mechanical

| | |
|---------------------|------------------------|
| Ambient temperature | -40°C ~ +105°C |
| Screw, Torque | M3, 0.45Nm (4.0Lb-In.) |

Dimensions

| | |
|-------|---------|
| Pitch | 5.00mm |
| Poles | 2P + 3P |

Material

| | |
|------------|------------------------------|
| Housing | PA66 (UL94V-0) |
| Pin header | Brass, Tin-plated |
| Screw | steel, Zinc-plated |
| Wire guard | Phosphore Bronze, Tin plated |



Wire Protector Terminal Block /
Pitch 5.00mm

Part No.: A12L055

| | | | | | | | | | | |
|-------|-------|------|------|--------|-------|-----------|-----|-----------|------------|-----------|
| DRW: | Bill | CHKD | Lord | MATL: | Jimmy | TOLERANCE | Sam | DATE | 14.03.2009 | Customer: |
| APPD: | Louis | | | FINISH | Georg | | | Sheet No. | 1 from 3 | |

www.edcon-components.com

email: info@edcon-components.com

EDCON-COMPONENTS



Ordering Informations

| Serie | - | No. of Pole | Body-Color | wire protector | Screw | - | Customer Request |
|---------|---|-------------|------------|----------------|-------|---|------------------|
| A12L055 | - | XX | XX | X | X | - | X |

| | | | |
|------------|------------|----------------------------|------------------------------------|
| XX = total | WH - white | 1 - with wire protector | A - Slotted screw |
| 02 | GN - green | 2 - without wire protector | B - Cross-slotted screw (standard) |
| 03 | GR - gray | | |

| |
|-----------------------|
| LG - light gray |
| PG - Phoenix Green |
| OR - orange |
| BL - blue |
| BK - black (standard) |

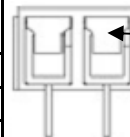

wire protector

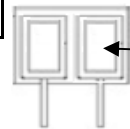

without wire protector



Wire Protector Terminal Block /
Pitch 5.00mm

Part No.: A12L055

Customer:

| | | | | | | | | | |
|-------|-------|------|------|--------|-------|-----------|-----------|------|------------|
| DRW: | Bill | CHKD | Lord | MATL: | Jimmy | TOLERANCE | Sam | DATE | 14.03.2009 |
| APPD: | Louis | | | FINISH | Georg | | Sheet No. | | 2 from 3 |

www.edcon-components.com

email: info@edcon-components.com



Soldering - Profil

Classification Reflow Profile (JEDEC J-STD-020C)



Wire Protector Terminal Block /
Pitch 5.00mm

Part No.: A12L055

Customer:

| | | | | | | | | | |
|-------|-------|------|------|--------|-------|-----------|-----------|----------|------------|
| DRW: | Bill | CHKD | Lord | MATL: | Jimmy | TOLERANCE | Sam | DATE | 14.03.2009 |
| APPD: | Louis | | | FINISH | Georg | | Sheet No. | 3 from 3 | |