

ESD5V0L4

5 Volts ESD Protection Device

SOT-553

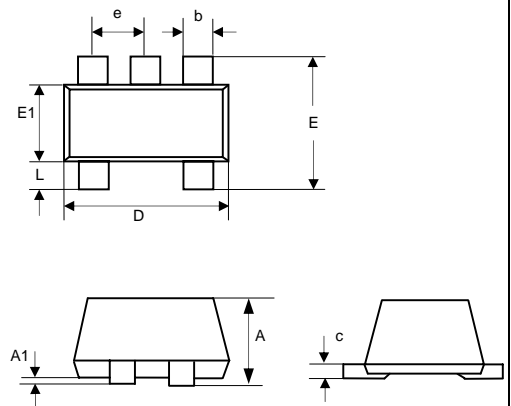

DIM	INCHES		MM	
	MIN	MAX	MIN	MAX
A	.021	.024	.525	.60
A1	.00	.002	.00	.05
e	.018	.022	.45	.55
c	.004	.006	.09	.16
D	.059	.067	1.5	1.7
b	.007	.011	.17	.27
E1	.043	.051	1.1	1.3
E	.059	.067	1.5	1.7
L	.004	.012	.100	.300

Features

- For sensitive ESD protection
- Excellent clamping capability
- Low leakage
- ESD rating of class 3(>16KV)per Human Body Mode
- For space saving application
- Fast response ,response time less than 1ns.
- Case Material: Molded Plastic. UL Flammability Classification Rating 94V-0 and MSL rating 1

Maximum Ratings

- Operating Junction & Storage Temperature: -55°C to +150°C
- Maximum Thermal Resistance; 833°C/W Junction To Ambient

Parameter	Symbol	Limits	unit
IEC61000-4-2(ESD) Air Contact		±30 ±30	KV
ESD Voltage per human body mode per machine mode		16 400	KV V
Power Dissipation(Note 1)	Pd	150	mw
Peak Power Dissipation@8/20us	Ppk	200	W

1. Only 1 diode under power. For all 4 diodes under power, PD will be 25%. Mounted on FR--4 board with min pad.

Pin Configuration

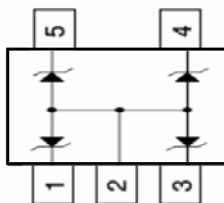

ELECTRICAL CHARACTERISTICS ($T_A = 25^\circ\text{C}$ unless otherwise noted, $V_F = 0.9\text{ V Max.}$ @ $I_F = 10\text{mA}$ for all types)

Device*	Device Marking	V_{RWM} (V)	I_R (μA) @ V_{RWM}	V_{BR} (V) @ I_T		I_T mA	V_F (V) @ $I_F=200\text{mA}$	V_C (V) @Max $I_{pp}=1\text{A}$	V_C (V) @Max $I_{pp}=5\text{A}$	C (pF) Max
		Max	Max	Min	Max		Max	Max	Max	
ESD5V0L4	42	5.0	5	6.0	7.2	1.0	1.25	10.5	13.5	80

1. Non-repetitive current per Figure 1. Derate per Figure 2.

TYPICAL CHARACTERISTICS

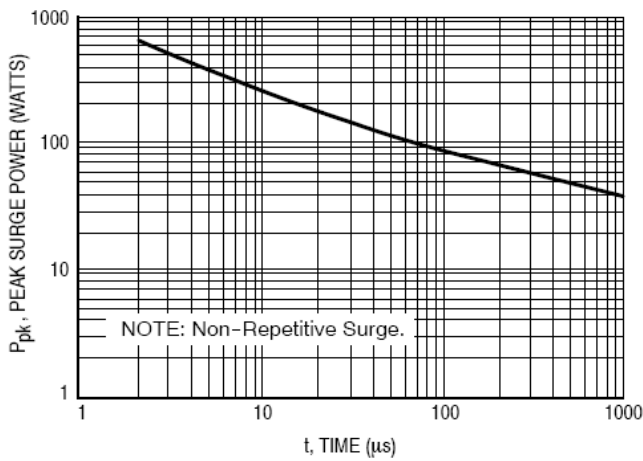

Figure 1. Pulse Width

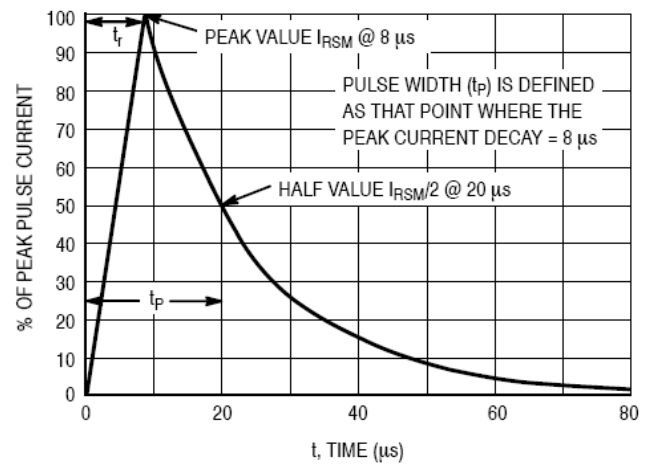

Figure 2. $8 \times 20\ \mu\text{s}$ Pulse Waveform

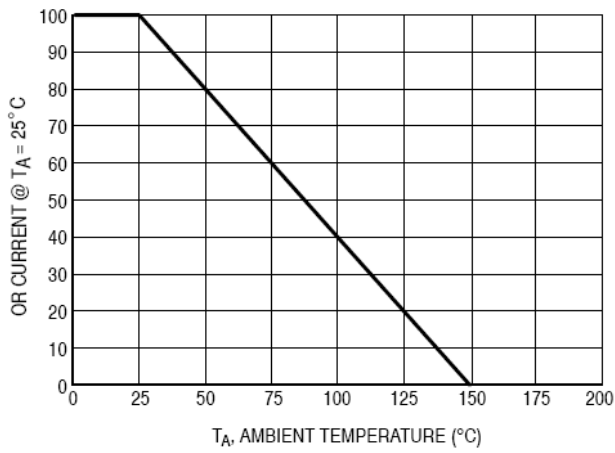

Figure 3. Pulse Derating Curve

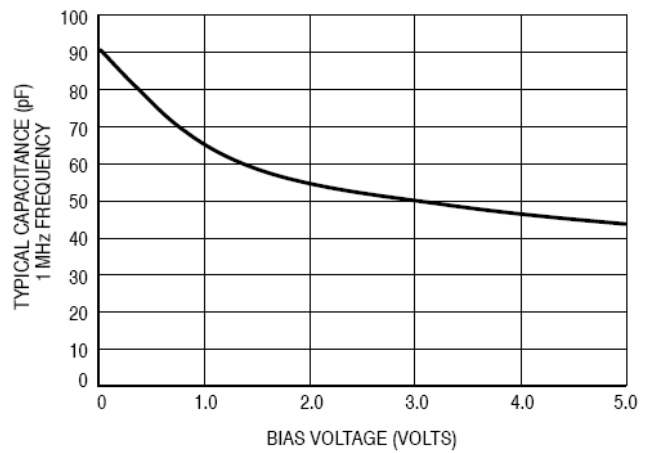

Figure 4. Capacitance

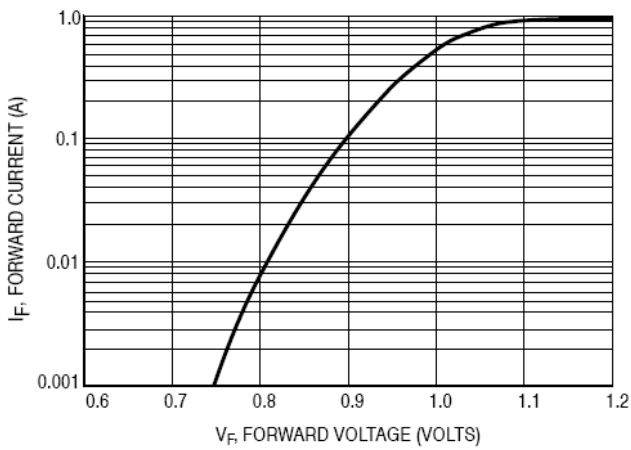

Figure 5. Forward Voltage

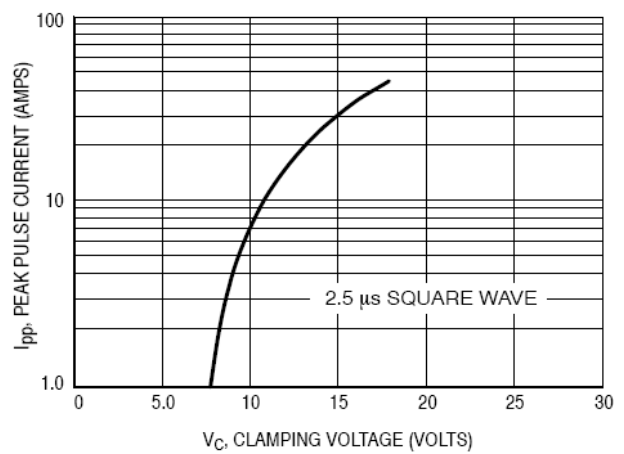

Figure 6. Clamping Voltage versus Peak Pulse Current (Reverse Direction)

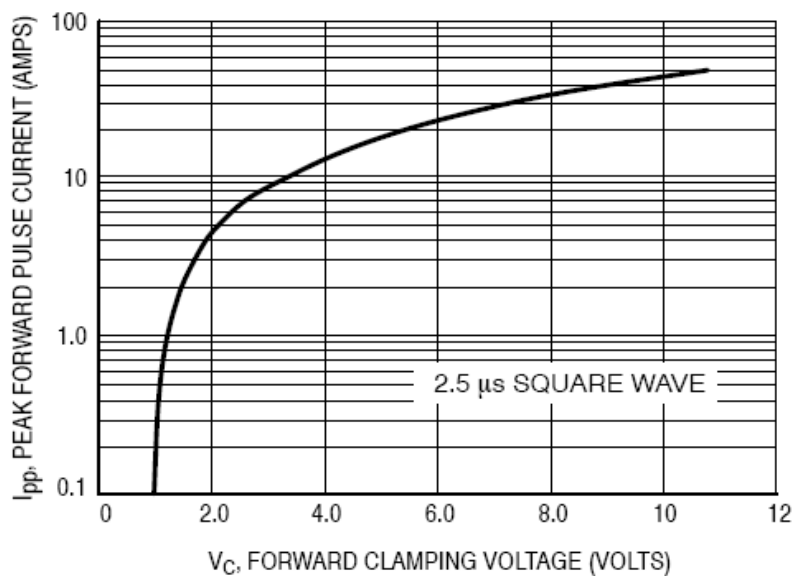

Figure 7. Clamping Voltage versus Peak Pulse Current (Forward Direction)

Ordering Information

Device	Packing
(Part Number)-TP	Tape&Reel;3Kpcs/Reel