

ESD3V3D5 Thru ESD12VD5

Features

- For sensitive ESD protection
- Excellent clamping capability
- Low leakage
- ESD rating of class 3(>16KV)per Human Body Mode
- For space saving application
- Fast response ,response time less than 1ns.
- Case Material: Molded Plastic. UL Flammability Classification Rating 94V-0 and MSL rating1

Maximum Ratings

- Operating Junction &StorageTemperature: -55°C to +150°C
- Maximum Thermal Resistance: 625°C/W Junction To Ambient

Parameter	Symbol	Limits	unit
IEC61000-4-2(ESD) Air Contact		±30 ±30	KV
ESD Voltage per human body mode per machine mode		16 400	KV V
Power Dissipation	Pd	200	mw

3.3V~12Volts ESD Protection Devices

SOD523

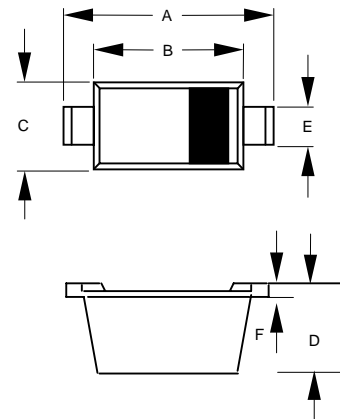

DIMENSIONS			
DIM	INCHES	MM	NOTE
	Typ	Typ	
A	.063	1.60	
B	.472	1.20	
C	.032	0.80	
D	.026	0.65	
E	.012	0.30	
F	.004	0.10	

ELECTRICAL CHARACTERISTICS ($T_A = 25^\circ\text{C}$ unless otherwise noted)

Symbol	Parameter
I_{PP}	Maximum Reverse Peak Pulse Current
V_C	Clamping Voltage @ I_{PP}
V_{RWM}	Working Peak Reverse Voltage
I_R	Maximum Reverse Leakage Current @ V_{RWM}
V_{BR}	Breakdown Voltage @ I_T
I_T	Test Current
I_F	Forward Current
V_F	Forward Voltage @ I_F
P_{pk}	Peak Power Dissipation
C	Max. Capacitance @ $V_R=0$ and $f=1\text{MHz}$

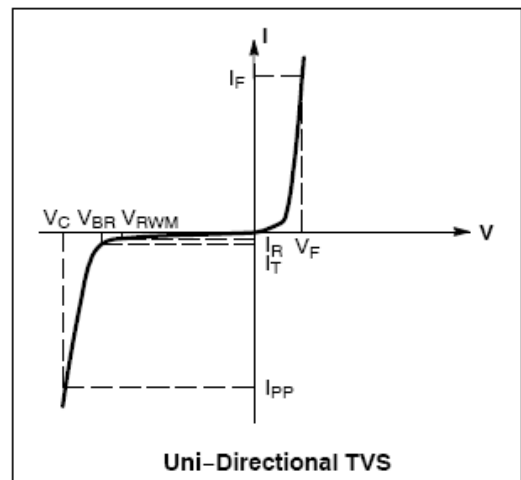

ELECTRICAL CHARACTERISTICS ($T_A = 25^\circ\text{C}$ unless otherwise noted, $V_F = 0.9\text{ V Max.}$ @ $I_F = 10\text{mA}$ for all types)

Device*	Device Marking	V_{RWM} (V)	I_R (μA) @ V_{RWM}	V_{BR} (V) @ I_T (Note 2)	I_T	V_C @ $I_{PP}^* = 5\text{ A}$	I_{PP}^* (A)	V_C (V) @ Max I_{PP}^*	P_{pk}^* (W)	C (pF)
		Max	Max	Min		mA		V		
ESD3V3D5	ZE	3.3	0.08	5.0	1.0	9.4	11.2	14.1	158	105
ESD5V0D5	ZF	5.0	0.08	6.2	1.0	11.6	9.4	18.6	174	80
ESD7V0D5	ZH	7.0	0.03	7.5	1.0	13.5	8.8	22.7	200	65
ESD12VD5	ZM	12	0.02	14.1	1.0	23	9.6	29	240	55

+Surge current waveform per Figure 1.

2. V_{BR} is measured with a pulse test current I_T at an ambient temperature of 25°C .

TYPICAL CHARACTERISTICS

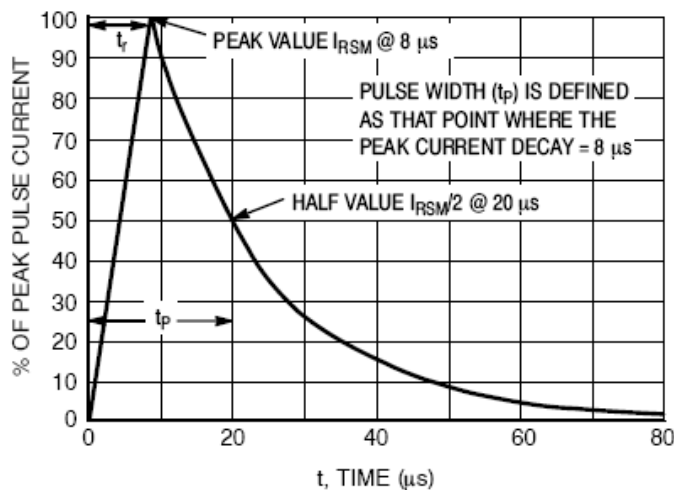

Figure 1. 8 x 20 μs Pulse Waveform

Ordering Information

Device	Packing
(Part Number)-TP	Tape&Reel;3Kpcs/Reel