

TM

RB480K

Features

- Low Current Rectification
- High Reliability
- Marking: 3T
- Case Material: Molded Plastic. UL Flammability Classificatio Rating 94-0 and MSL Rating 1

40 Volts Schottky Barrier Diode

Maximum Ratings

Symbol	Parameter	Rating	Unit
V_{RM}	Peak Reverse Voltage	45	V
V_R	DC Reverse Voltage	40	V
I_O	Mean Rectifying Current	0.1	A
I_{FSM}	Peak Forward Surge Current	1	A
T_J	Junction Temperature	125	°C
T_{STG}	Storage Temperature	-40 to +125	°C

Electrical Characteristics @ 25°C Unless Otherwise Specified

Symbol	Parameter	Min	Typ	Max	Units
OFF CHARACTERISTICS					
V_F	Forward Voltage ($I_F=10mA_{dc}$) ($I_F=100mA_{dc}$)	---	---	0.45 0.60	Vdc
I_R	Reverse Current ($V_R=10V_{dc}$) ($V_R=40V_{dc}$)	---	---	1 5	μA_{dc}
C_D	Diode Capacitance ($V_R=0V$) ($V_R=10V, f=1MHz$)	---	6	25	pF

Pin Orientation in the Tape

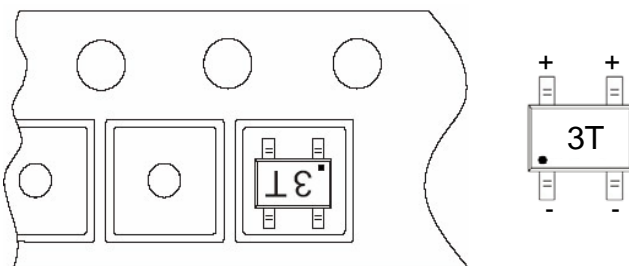

SOT-343

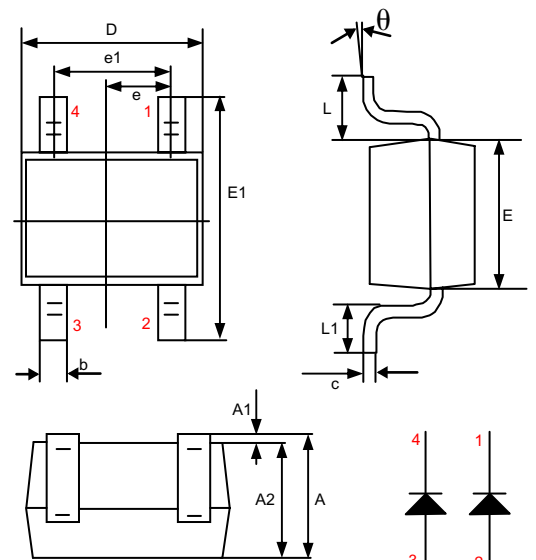

DIM	DIMENSIONS				NOTE
	INCHES		MM		
	MIN	MAX	MIN	MAX	
A	.035	.043	0.90	1.10	
A1	---	.004	---	0.10	
A2	.035	.039	0.9	1.00	
b	.006	.014	0.15	0.35	
c	.003	.006	0.08	0.15	
D	.079	.087	2.00	2.20	
E	.045	.053	1.15	1.35	
E1	.085	.096	2.15	2.45	
e	.026TYP		0.65TYP		
e1	.047	.055	1.20	1.40	
L	.021REF		0.525REF		
L1	.010	.018	0.26	0.46	
ø	0"	8"	0"	8"	

RB480K

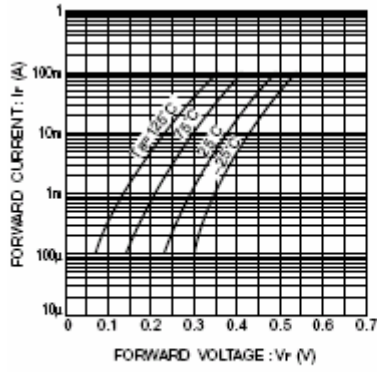

Fig.1 Forward temperature characteristics

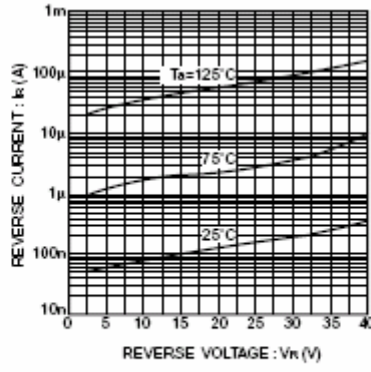

Fig.2 Reverse temperature characteristics

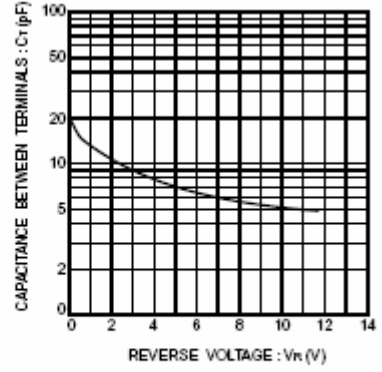

Fig.3 Capacitance between terminals characteristics

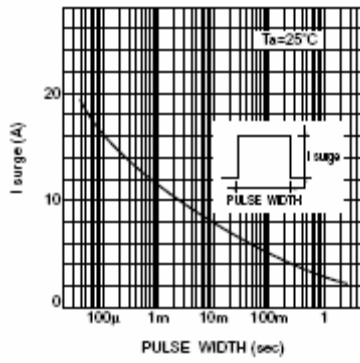
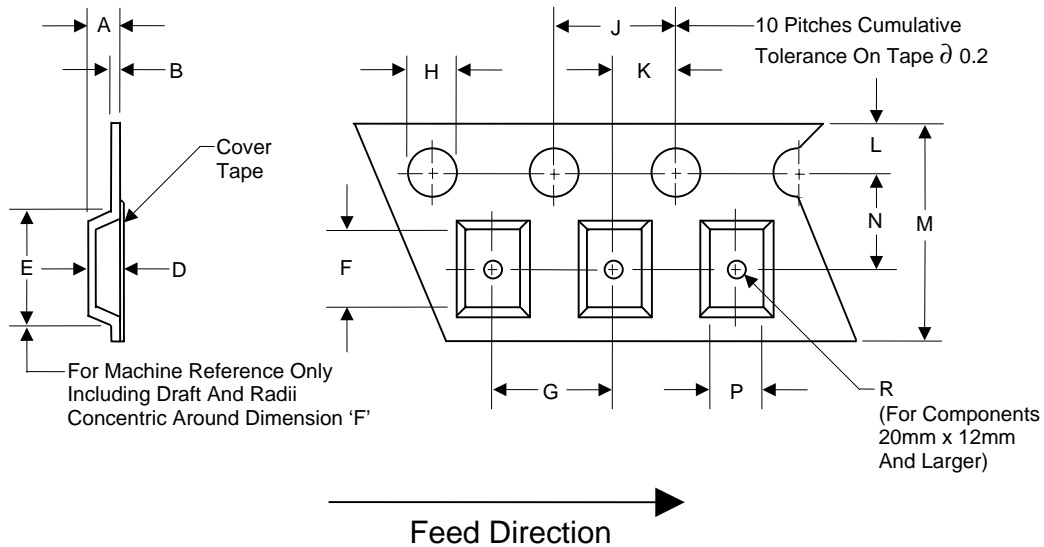

Fig.4 Surge current characteristics

SURFACE MOUNT

Embossed Carrier Tape Specifications (8, 12, 16, 24mm Tape)



Tape Size	H	L	J	B (Max)	D, F, P	Constant Dimensions
8,12,16,24	1.5 _{+0.1, -0.0}	1.75 \pm 0.10	4.0 \pm 0.1	0.600	See Note 1	

Tape Size	E (Max)	R (Min)	N	A (Max)	K	M	Variable Dimensions
8mm	4.2	1.0	3.5 \pm 0.05	2.4	2.0 \pm 0.05	8.0 \pm 0.30	
12mm	8.2	1.5	5.5 \pm 0.05	4.5	2.0 \pm 0.05	12.0 \pm 0.30	
16mm	12.1	1.5	7.5 \pm 0.10	6.5	2.0 \pm 0.10	16.0 \pm 0.30	
24mm	20.1	1.5	11.5 \pm 0.10	11.9	2.0 \pm 0.10	24.0 \pm 0.30	

Tape Size	G			
	4.0 \pm 0.10	8.0 \pm 0.10	12.0 \pm 0.10	16.0 \pm 0.10
8mm	X			
12mm	X	X		
16mm	X	X	X	
24mm				X

Note: D, F, P are determined by constant size. The clearance between the part and the tape cavity must be within 0.05mm min. to 0.50mm max. for 8mm tape, 0.05mm min. to 0.65mm max. for 12mm tape and 0.05mm min. to 0.90mm max. for 16mm tape.

SURFACE MOUNT

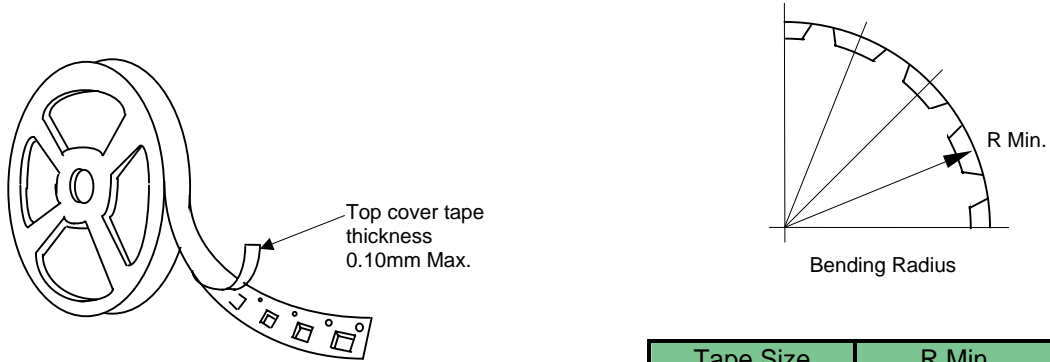

Tape Size	R Min.
8mm	25mm
12mm	30mm
16mm	30mm
24mm	30mm

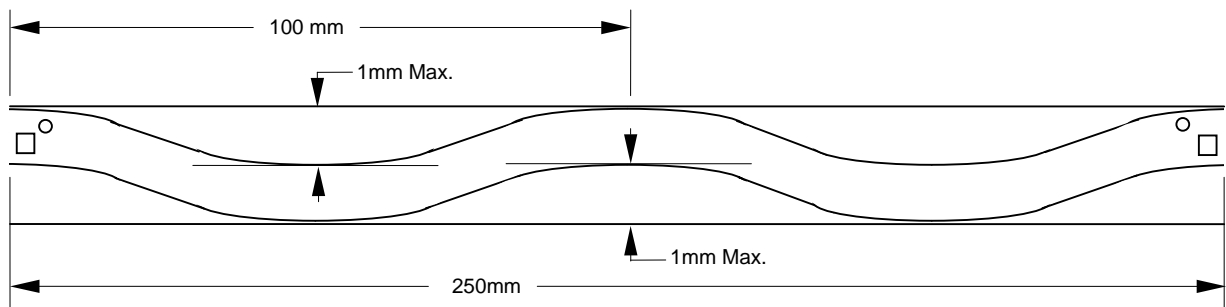

Camber (Top View)

Allowable camber to be 1mm/100mm non-accumulative over 250mm

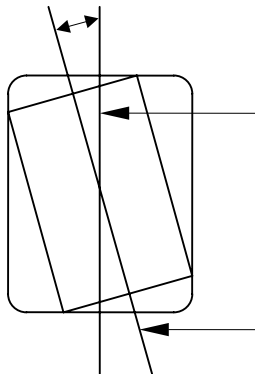

SURFACE MOUNT

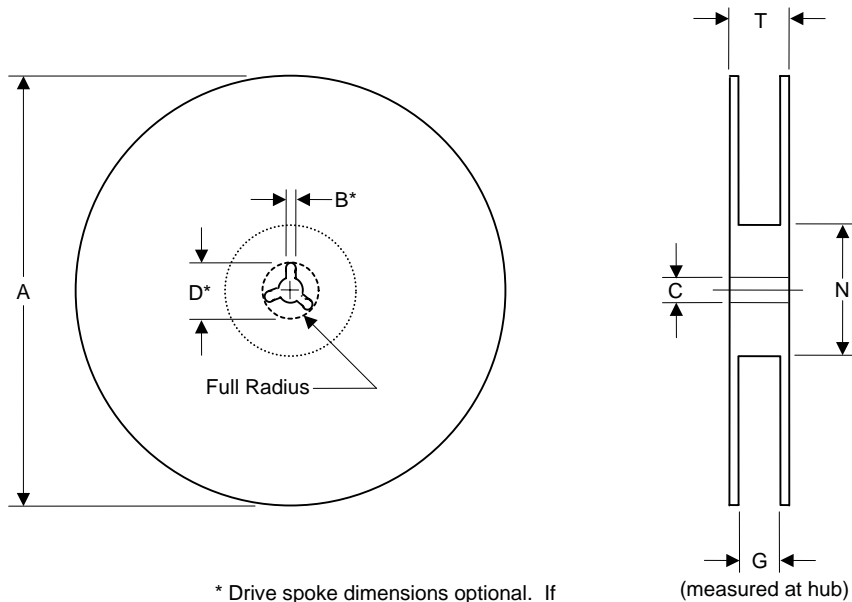

* Drive spoke dimensions optional. If drive spoke is used then asterisked dimensions apply.

Tape Size	A Max.	B* Min.	C	D* Max.	N Min.	G	T Max.
8mm	330	1.5	13.0 \pm 0.20	20.2	75	8.4 ^(+1.5/-0.0)	14.4
12mm	330	1.5	13.0 \pm 0.20	20.2	75	12.4 ^(+2.0/-0.0)	18.4
16mm	360	1.5	13.0 \pm 0.20	20.2	75	16.4 ^(+2.0/-0.0)	22.4
24mm	360	1.5	13.0 \pm 0.20	20.2	75	24.4 ^(+2.0/-0.0)	30.4

Start And Finish Specifications

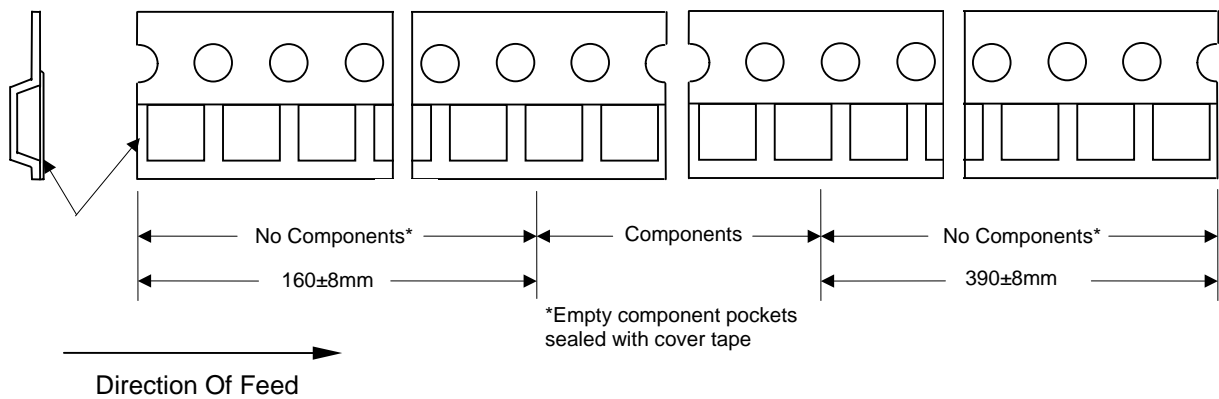

Ordering Information

Device	Packing
(Part Number)-TP	Tape&Reel;3Kpcs/Reel

■

■

■

■
