

LL48

Small Signal Schottky Diode

Features

- Fast Switching Speed and Low Turn-on Voltage
- Protected by a PN junction guard ring against excessive
- For General Purpose Application
- Lead Free Finish/RoHS Compliant(Note 1) ("P" Suffix designates

Mechanical Data

- Case: Minimelf, Glass
- Terminals: Solderable per MIL-STD-202, Method 208
- Polarity: Indicated by Cathode Band
- Weight: 0.05 grams (approx.)

Maximum Ratings @ 25°C Unless Otherwise Specified

Characteristic	Symbol	Value	Unit
Peak Reverse Voltage	V_{RRM}	40	V
Forward Continuous Current(Note2)	I_F	350	mA
Surge Forward Current @ $t_p < 10ms$, $T_A=25^\circ C$	I_{FSM}	7.5	A
Power Dissipation(Note 2)	P_{tot}	330	mW
Thermal Resistance(Note 2)	$R_{\theta JA}$	300	K/W
Operation Temperature Range	T_A	-55 to 125	°C
Storage Temperature Range	T_{STG}	-55 to 150	°C

Electrical Characteristics @ 25°C Unless Otherwise Specified

Charateristic	Symbol	Min	Typ.	Max	Unit	Test Cond.
Reverse Breakdown Volt.	$V_{(BR)R}$	40	-----	-----	V	100uA pulse
Reverse Leakge Current.	I_R	-----	-----	2 15 5 25 25 50	uA	$V_R=10V$ $V_R=10V, T_J=60^\circ C$ $V_R=20V$ $V_R=20V, T_J=60^\circ C$ $V_R=40V$ $V_R=40V, T_J=60^\circ C$
Forward Volt. Drop	V_F	-----	-----	0.25 0.45 0.90	V	$I_F=0.1mA$ $I_F=10mA$ $I_F=250mA$
Junction Capacitance	C_{tot}	-----	2.0	-----	pF	$V_R=1V, f=1MHz$

Note: 1. Lead in Glass Exemption Applied, see EU Directive Annex 5.

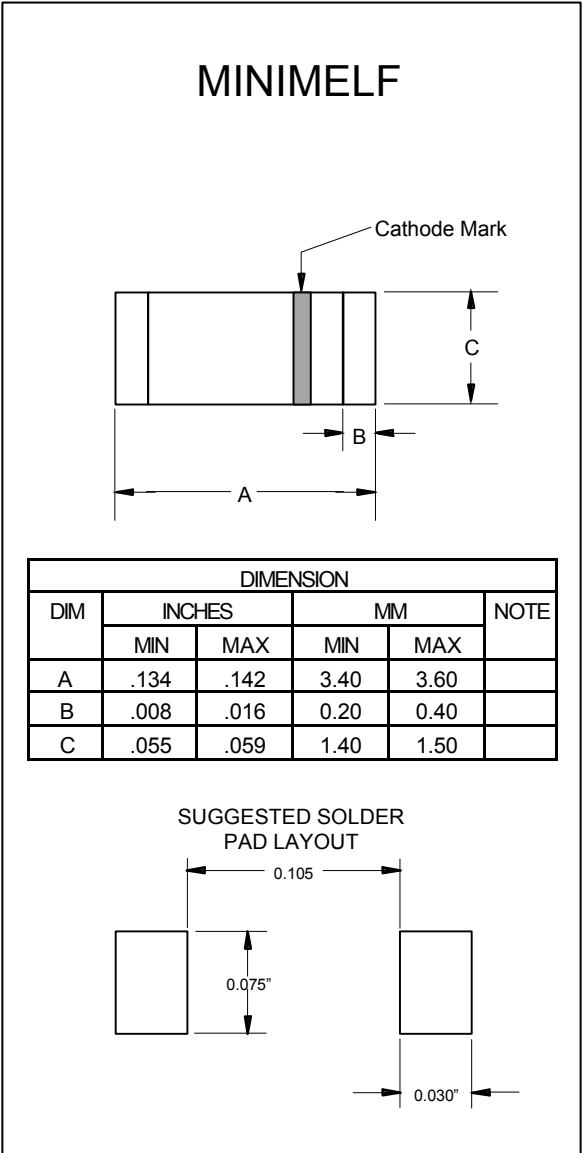

LL48

TM

Figure 1. Forward current versus forward voltage at different temperatures (typical values)

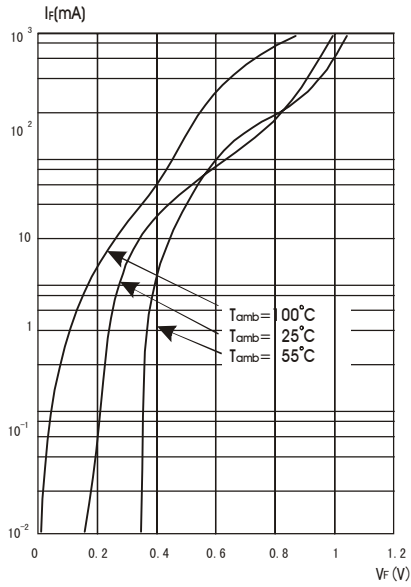

Figure 2. Forward current versus forward voltage (typical values)

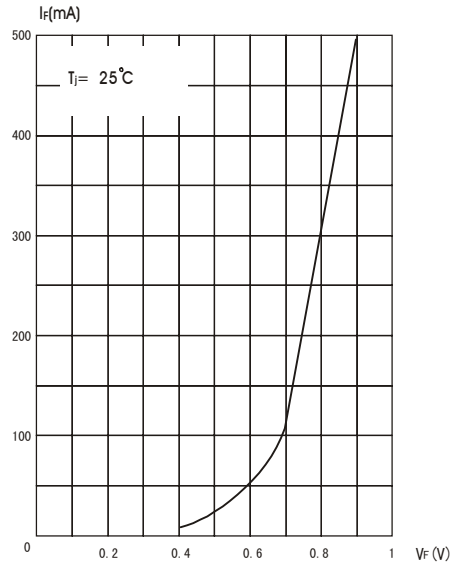
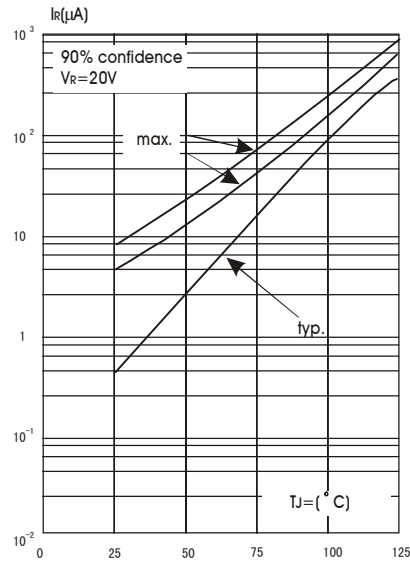

Figure 3. Reverse current versus ambient temperatures



LL48

TM

Figure 4. Reverse current versus continuous Reverse voltage (typical values)

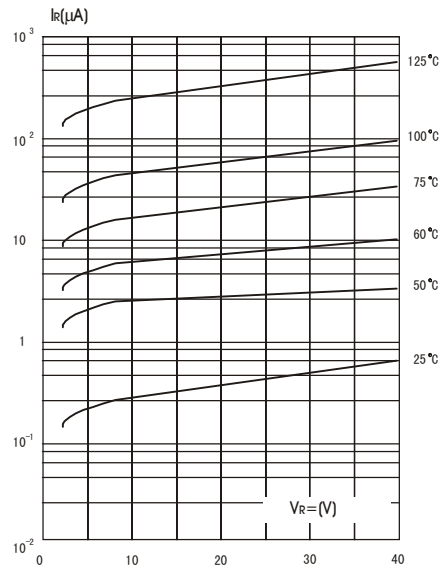
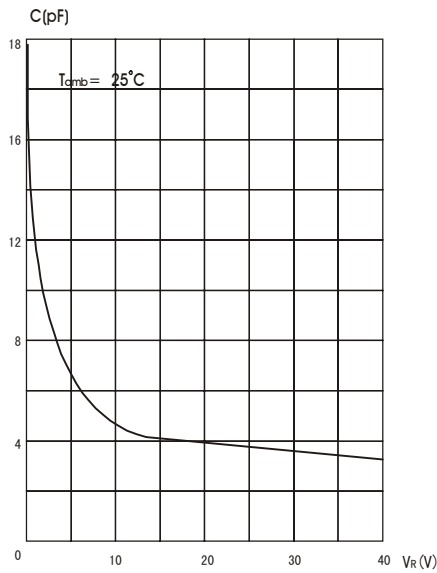

Figure 5. Capacitance C versus reverse applied voltage V_R (typical values)



Ordering Information

Device	Packing
(Part Number)-TP	Tape&Reel;2.5Kpcs/Reel

■

■

■

■
