

BAS40WX

Surface Mount Schottky Barrier Diode

- Fast Switching Speed
- Low Turn-on Voltage
- Surface Mount Package Ideally Suited for Automatic Insertion
- PN Junction Guard Ring for Transient and ESD Protection

Mechanical Data

- Marking: 43
- Polarity: Indicated by Cathode Band
- Case Material: Molded Plastic. UL Flammability Classification Rating 94V-0 and MSL Rating 1

Maximum Ratings @ 25°C Unless Otherwise Specified

Characteristic	Symbol	Value	Unit
Peak Repetitive Reverse Voltage	V_{RRM}		
Working Peak Reverse Voltage	V_{RWM}	40	V
DC Blocking Voltage	V_R		
RMS Reverse Voltage	$V_{R(RMS)}$	28	V
Forward Continuous Current(Note1)	I_{FM}	200	mA
Forward Surge Current @ $t < 1.0s$	I_{FSM}	600	mA
Power Dissipation(Note 1)	P_d	350	mW
Thermal Resistance(Note 1)	R	357	°C/W
Operation Temp. Range	T_j	-55 to +125	°C
Storage Temp. Range	T_{STG}	-65 to +150	°C

Electrical Characteristics @ 25°C Unless Otherwise Specified

Charateristic	Symbol	Min	Typ	Max	Unit	Test Cond.
Forward Voltage	V_F	-----	-----	0.38 1	V	$t_p < 300\mu s$ $I_F = 1.0mA$ $t_p < 300\mu s$ $I_F = 40mA$
Reverse Leakage Current	I_R	-----	20	200	nA	$t_p < 300\mu s$ $V_R = 30V$
Junction Capacitance	C_j	-----	4	5	pF	$V_R = 0V$, $f = 1.0MHz$
Reverse Recovery Time	t_{rr}	-----	-----	5	ns	$I_F = I_R = 10mA$ $I_R = 1.0mA$, $R_L = 100\Omega$

SOD-323

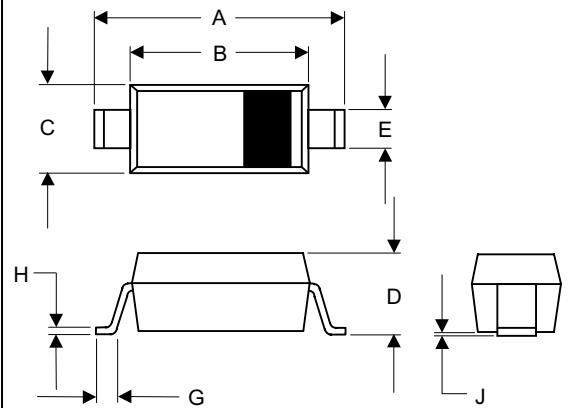

DIM	INCHES		MM		NOTE
	MIN	MAX	MIN	MAX	
A	.090	.107	2.30	2.70	
B	.063	.071	1.60	1.80	
C	.045	.053	1.15	1.35	
D	.031	.045	0.80	1.15	
E	.010	.016	0.25	0.40	
G	.004	.018	0.10	0.45	
H	.004	.010	0.10	0.25	
J	-----	.006	-----	0.15	

SUGGESTED SOLDER PAD LAYOUT

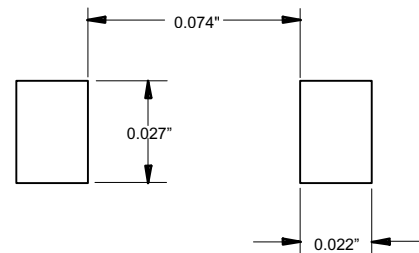

Ordering Information

Device	Packing
(Part Number)-TP	Tape&Reel;3Kpcs/Reel