

EDCON-COMPONENTS



Technical Discription

Standard: UL248-1 + UL 248-14
Operating Temperature: . -55°C ~ + 125°C
Storage Temperature: . -55°C ~ + 85°C
Solderability: MIL-STD-202, Method 208

Electrical Characteristics:

% of Current Rating:
 100% 4 hours
 200% 5 seconds max. (100mA ~15A)
 200% 20 seconds max. (12A ~15A)

Interrupting Capacity

50A at 250VAC (100mA ~ 10A) 50A at 125VAC (12A ~ 15A)
 100A at 125V DC/AC (100mA ~ 10A) 100A at 65V DC/AC (12A ~ 15A)

Range Code: 6A30

Range: 6A30= 6,3A

Drawing (mm)

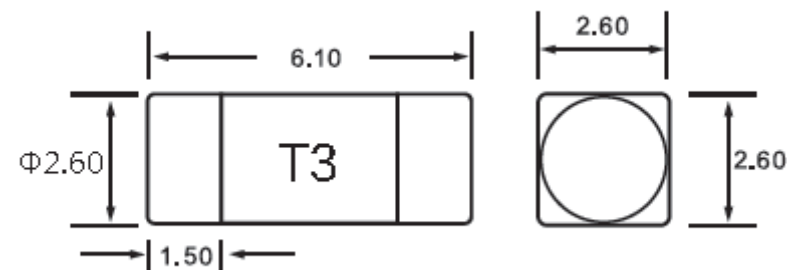

PCB Drawing (mm)

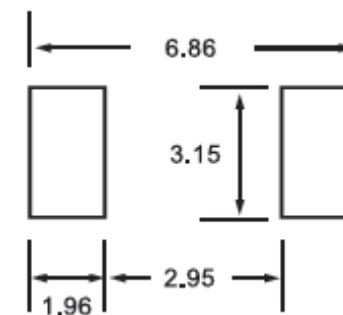

Packing (Box 1000PCS Tape/Reel)

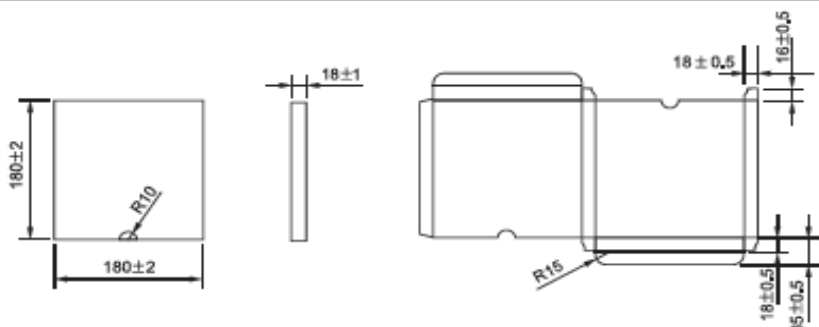

SMD NANO Fuse Fast Blow

Part No.: R14003

Customer:

DRW:	Jason	CHKD	Wilson	MATL:	Wilson	TOLERANCE	Mason	DATE	11.05.2014
APPD:	Schumi			FINISH	Jamy		Sheet No.		1 from 4



Current Characteristics Curve

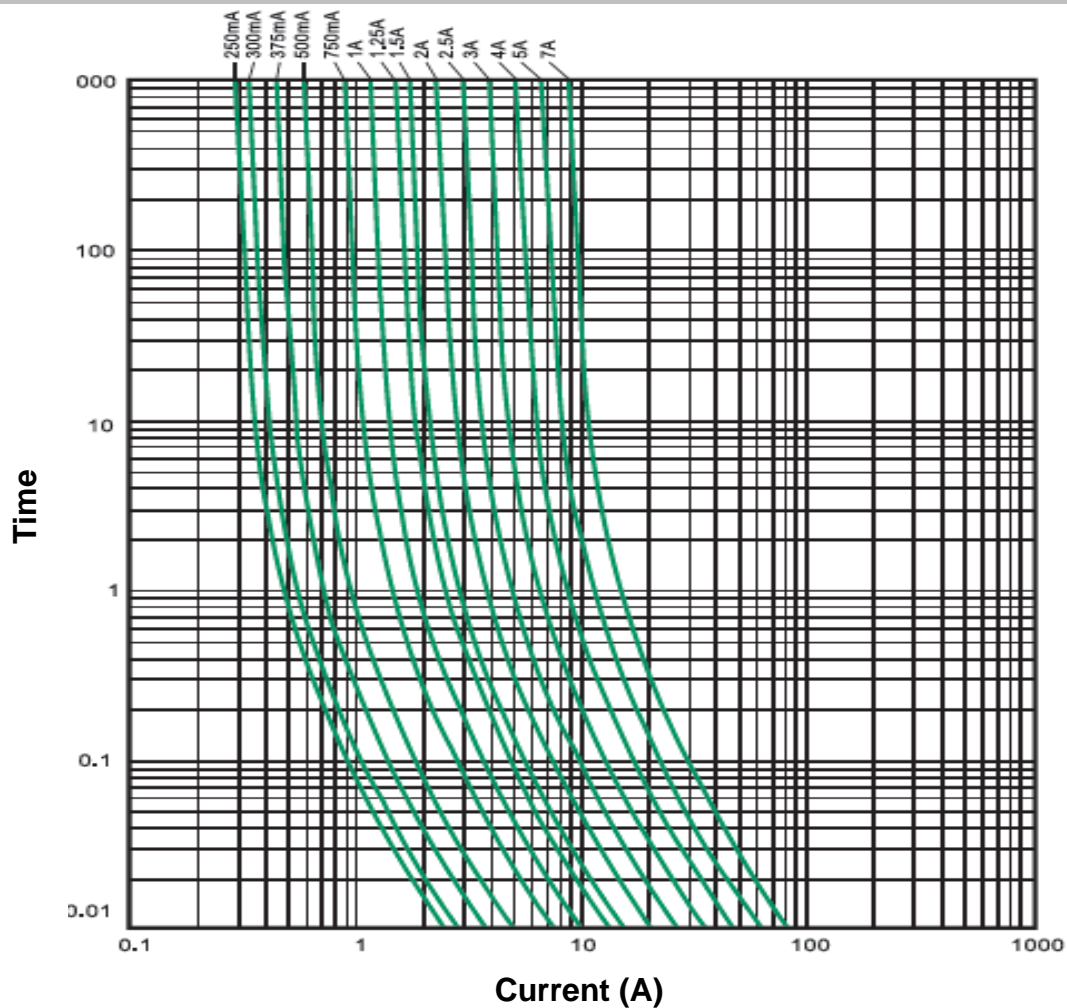

SMD NANO Fuse Slow Blow	
Part No.:	R14003
Customer:	

DRW:	Jason	CHKD	Wilson	MATL:	Wilson	TOLERANCE	Mason	DATE	11.05.2014
APPD:	Schumi			FINISH	Jamy		Sheet No.	2 from 4	

EDCON-COMPONENTS



Ordering Informations

Serie	Range Code	Voltage	ROHS	Packing						
-------	------------	---------	------	---------	--	--	--	--	--	--

R14003	-	6A30	A	R	TR					
--------	---	------	---	---	----	--	--	--	--	--

6A30= 6,3A	A= 250VAC (100mA~ 10A)	R= ROHS Conform	BU= Bulk- Ware 1000PCS
	B= 125VAC (100mA ~ 15A)		
	C= 65VAC (10A ~15A)		
			TR= Tape Reel 1000PCS standard

**SMD NANO Fuse Fast
Blow**

Part No.: **R14003**

DRW:	Jason	CHKD	Wilson	MATL:	Wilson	TOLERANCE	Mason	DATE	11.05.2014
APPD:	Schumi			FINISH	Jamy		Sheet No.		3 from 4

Customer:



Soldering Profile Curve

Classification Reflow Profile (JEDEC J-STD-020C)



SMD NANO Fuse Fast Blow

Part No.: **R14003**

DRW:	Jason	CHKD	Wilson	MATL:	Wilson	TOLERANCE	Mason	DATE	11.05.2014
APPD:	Schumi			FINISH	Jamy		Sheet No.	4 from 4	Customer: