

EDCON-COMPONENTS



Contact



Specifications

Voltage Rating: 30V max
 Current Rating: Pin 1~4 1,5A
 Operating Temperature: -20°C to + 60°C
 Contact Resistance: Pin 1~4 30mOhm

Insulation Resistance: 1000 Megaohm Min.
 Mating Force: 35 Newtons max.
 Unmating Force: 10 Newtons max.
 Material Housing: LCP, Nylon or PBT White/Black
 Contact: Copper Alloy
 Shell: copper alloy, SUS or SPCC
 Contact Plating: Au plated on contact area 0,75µ
 Tin paltd on solder area
 Nickel underplating overall

Shell: Nickel plating
 Lifetime: 5000 cycles

PCB-Layout

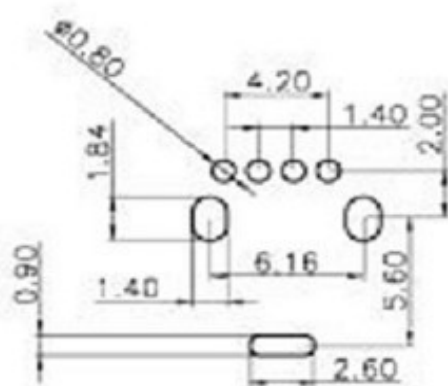

Drawing (dimensions all into mm)

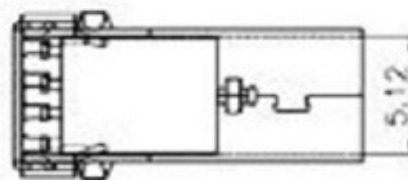
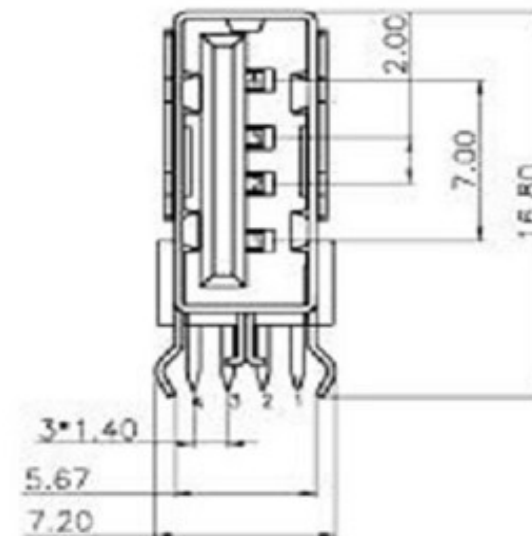
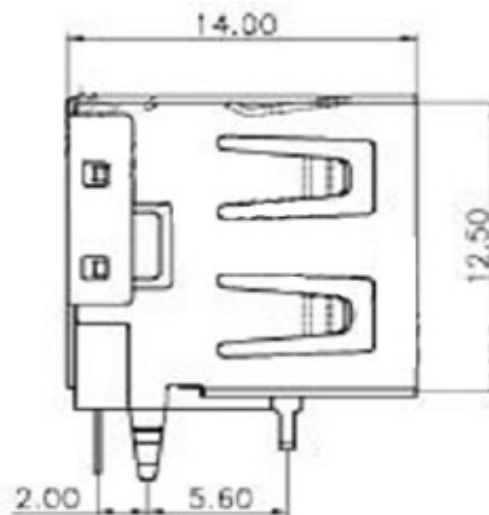

Tolerances unless otherwise specified (mm)

X	X.X	X.XX	X.XXX	Angle
±	±	±	±	±3°

USB-AF Connector w/o Flange

Part No.: **T65298-**

Customer:

DRW:	Jason	CHKD	Wilson	MATL:	Wilson
APPD:	Schumi			FINISH	Jamy

Mason	DATE	20.08.2022
Sheet No.	1 from 3	

www.edcon-components.com

email: info@edcon-components.com

EDCON-COMPONENTS



Contact



Ordering Informations

Serie	No of Pos.	Contact Plating	Contact Material	Body Colour Inside	Shell Material	Insulator Material	Special function	ROHS	Packing	
T65298-	04	GF	BR	BK	ST	PB	N	R	TY	

04= No of Contacts	GF= Gold Flash	BR= Brass	BK= Black	SS= Stainless Steel	PB= PBT + 30GF	N= No function	R= RoHS Conform	BU= Bulk-Ware
	TN= Tinned	PB= Phosphor Bronze	WH= White	BR= Brass	LC= LCP			TY= Tray Packing
				IR= Iron				TR= Tape Reel Packing

USB-AF Connector w/o Flange

Part No.: **T65298-**

DRW:	Jason	CHKD	Wilson	MATL:	Wilson	TOLERANCE	Mason	DATE	20.08.2022
APPD:	Schumi			FINISH	Jamy			Sheet No.	2 from 3

Customer:



Soldering Profile Curve

Classification Reflow Profile (JEDEC J-STD-020C)

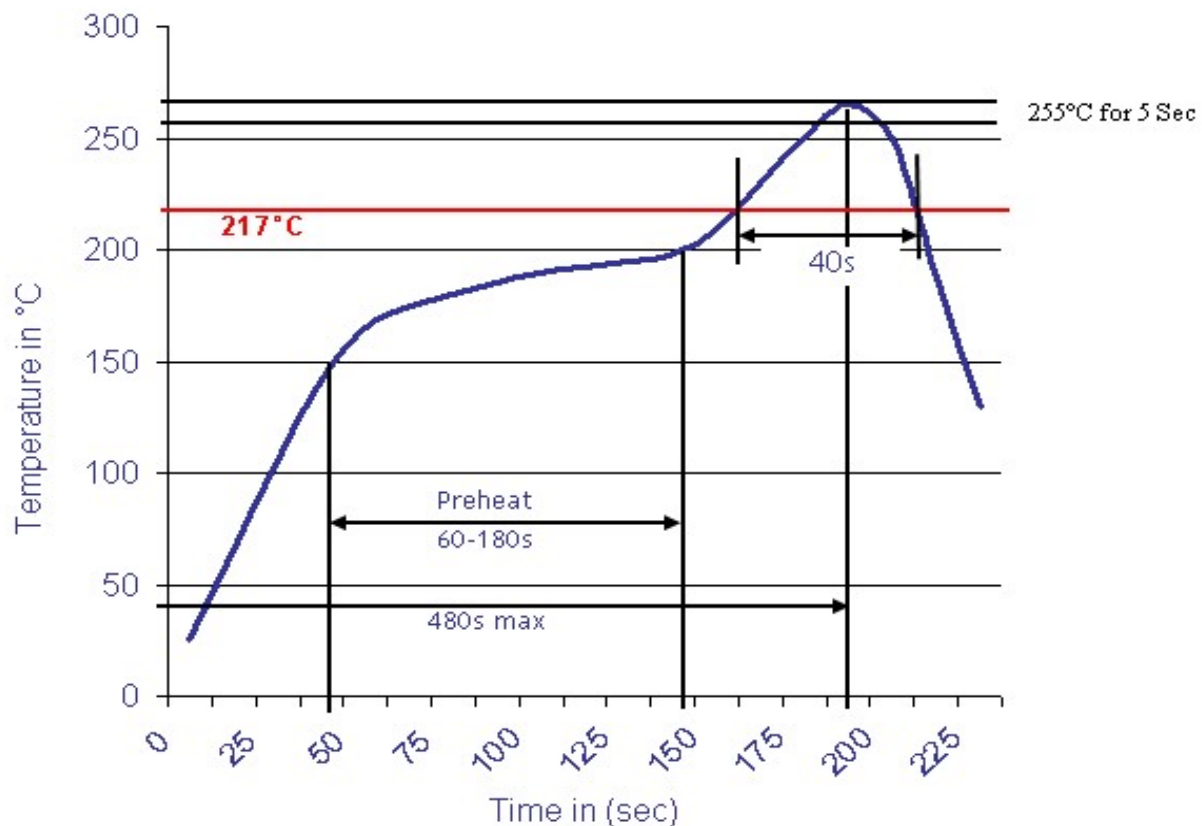

USB-AF Connector w/o Flange	
Part No.:	T65298-
Customer:	

DRW:	Jason	CHKD:	Wilson	MATL:	Wilson	TOLERANCE:	Mason	DATE:	20.08.2022
APPD:	Schumi	FINISH:	Jamy			Sheet No.:			3 from 3