



DATA SHEET

SUB-Miniature - Toogle Switch Type Solder Lug

Serie: Q48A401

SUB-Miniature - Toogle Switch Type Solder Lug	
Serie No.:	Q48A401
Customer:	

DRW:	Jason	CHKD	Wilson	MATL:	Wilson	TOLERANCE	Mason	DATE	18.12.2015
APPD:	Schumi			FINISH	Jamy		Sheet No.	1 from 10	

EDCON-COMPONENTS



Actuator Optional Order Code

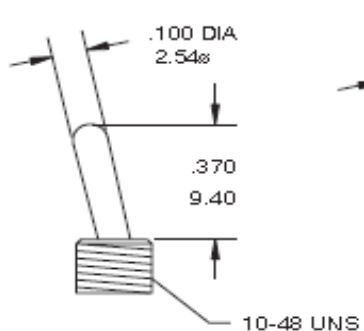

Code AA
Toggle Plastic Caps Look
Page 4

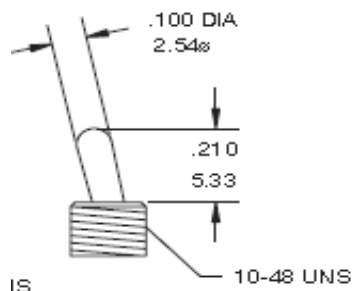

Code AB

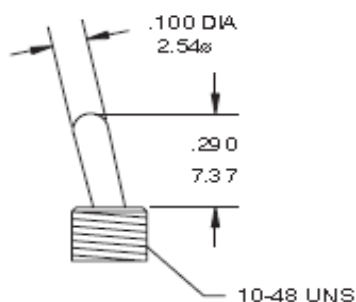

Code AC

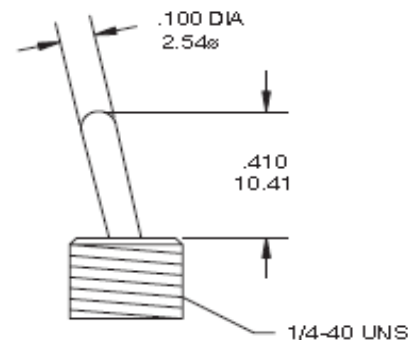

Code AD

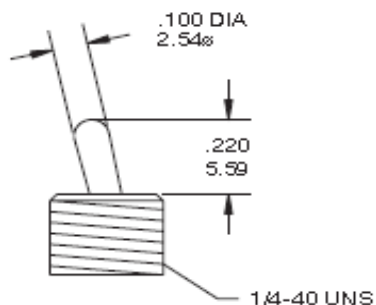

Code AE

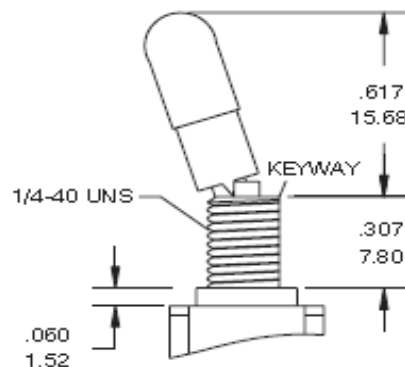

Code AF

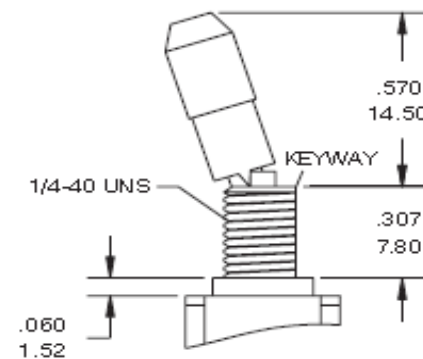

Code AG

SUB-Miniature - Toogle Switch Type Solder Lug	
Part No.:	Q48A401
Customer:	

DRW:	Jason	CHKD	Wilson	MATL:	Wilson	TOLERANCE	Mason	DATE	18.12.2015
APPD:	Schumi			FINISH	Jamy		Sheet No.		3 from 10



Actuator Optional Order Code

Toogle Plastic Caps Order Code Toogle Type AA		<p>Only for Actuator AA</p>
00	w/o Cap	
A1	white	
A2	black	
A3	red	
A4	yellow	
A5	green	
A6	blue	

SUB-Miniature - Toogle Switch Type Solder Lug	
Part No.:	Q48A401
Customer:	

DRW:	Jason	CHKD	Wilson	MATL:	Wilson	TOLERANCE	Mason	DATE	18.12.2015
APPD:	Schumi			FINISH	Jamy		Sheet No.	4 from 10	

EDCON-COMPONENTS



Bushing Options Order Code

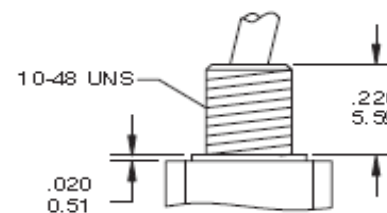
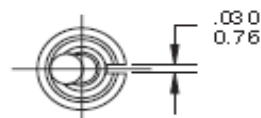
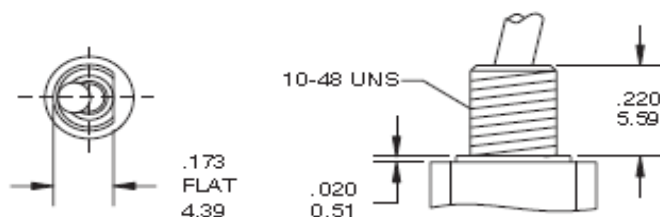

Code BA = with thread
Code BB = without thread

Code BC = with thread
Code BD = without thread

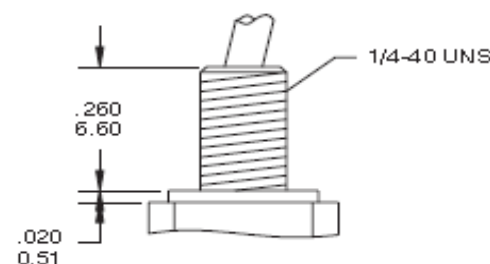
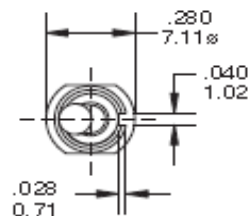
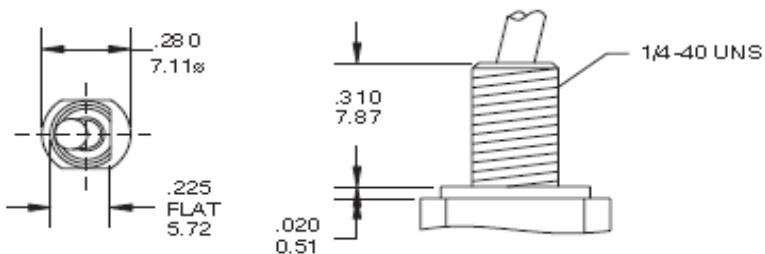

Code BE = with Thread
Code BF = without Thread

Code BF = with Thread
Code BG = without Thread

SUB-Miniature - Toogle Switch Type Solder Lug

Part No.: **Q48A401**

DRW:	Jason	CHKD	Wilson	MATL:	Wilson	TOLERANCE	Mason	DATE	18.12.2015
APPD:	Schumi			FINISH	Jamy		Sheet No.	5 from 10	

Customer:



Panel Mounting Informations

1/4 in. Bushing

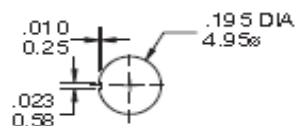

1/4 in. Bushing

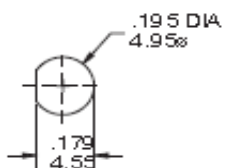

10-48 Bushing

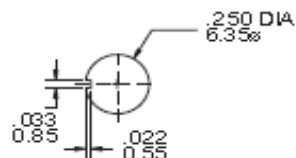

10-48 Bushing w/o look Ring

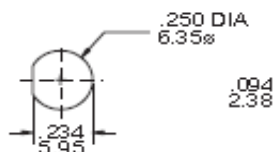

10-48 Bushing w .look Ring

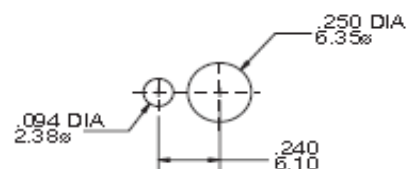

**SUB-Miniature - Toogle
Switch Type Solder Lug**

Part No.: **Q48A401**

DRW:	Jason	CHKD	Wilson	MATL:	Wilson	TOLERANCE	Mason	DATE	18.12.2015
APPD:	Schumi			FINISH	Jamy		Sheet No.	7 from 10	Customer:

EDCON-COMPONENTS



Terminal Option Order Code

Solder Lug Terminal

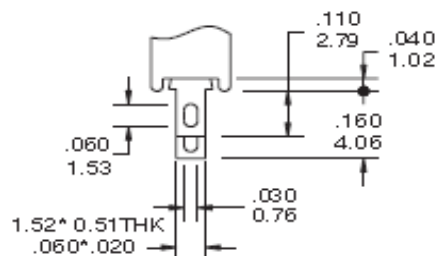

Code= A

PC Terminal

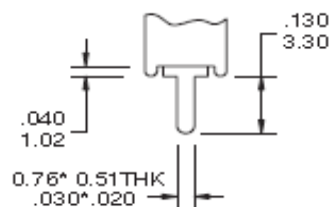

Code= B

Wire Wrap Terminal

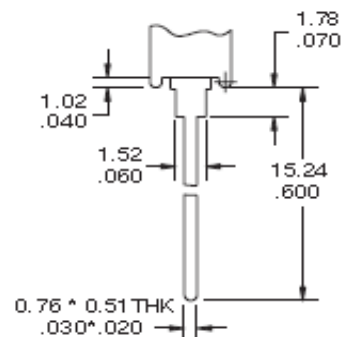

Code= C

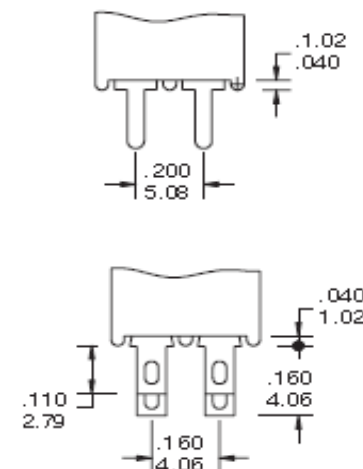

Terminal Seal Order Code



Code= 0 without Seal
Code= 1 with Seal

**SUB-Miniature - Toogle
Switch Type Solder Lug**

Part No.: **Q48A401**

DRW:	Jason	CHKD	Wilson	MATL:	Wilson	TOLERANCE	Mason	DATE	18.12.2015	Customer:
APPD:	Schumi			FINISH	Jamy		Sheet No.	7 from 10		

EDCON-COMPONENTS



Contact Material Order Code

Order Code	Contact Material	Terminal Material	Rating
A	Silver Plated	Silver Plated	5A @ 125VAC or 28VDC 3A @ 250VAC
B	Gold plated over nickel plated	Gold plated over nickel plated	0,4A max @20VAC or DC max.
C	Gold plated over silver plated	Gold plated over silver plated	0,4A max @20VAC or DC max.or 5A @ 125VAC or 28VDC 3A @ 250VAC

Locking Ring Order Code

Lock Washer Order Code

Standard 10-42

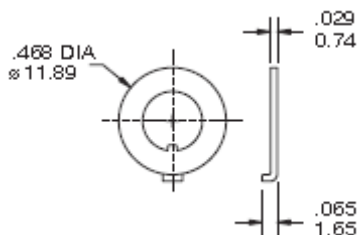

Code = A

Standard 1/4-40 Type 2

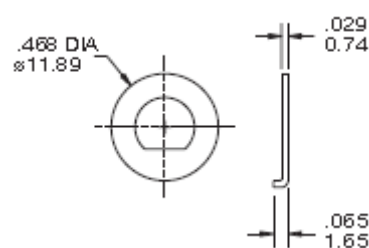

Code = B

Standard 10-42

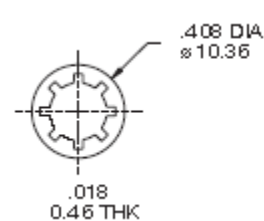

Code = 1

Standard 1/4-40

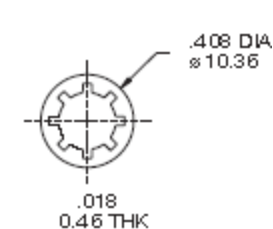

Code = 2

SUB-Miniature - Toogle Switch Type Solder Lug

Part No.: **Q48A401**

DRW:	Jason	CHKD	Wilson	MATL:	Wilson	TOLERANCE	Mason	DATE	18.12.2015	Customer:
APPD:	Schumi			FINISH	Jamy		Sheet No.	8 from 10		

EDCON-COMPONENTS



Ordering Informations

Serie	Switching Position	Toogle Options	Cap Options	Bushing Options	Terminal Options	Terminal Seal Options	Contact Mat. Options	Nut Options	Locking Options	Look Washer options	ROHS
Q48A401	1xx	Ax	xx	Bx	X	X	X	N	N	N	R
	Look Page 2	Look Page 3 + 4	Look Page 4	Look Page 5 + 6	Look Page 8	Look Page 8	Look Page 9	Look Page 10	Look Page 11	Look Page 11	R= ROHS Conform N= NON ROHS Conform

Packing Code

B

B= Bulk Ware
I= Individual Package

SUB-Miniature - Toogle Switch Type Solder Lug
Part No.: **Q48A401**
Customer:

DRW:	Jason	CHKD	Wilson	MATL:	Wilson	TOLERANCE	Mason	DATE	18.12.2015	Customer:
APPD:	Schumi			FINISH	Jamy		Sheet No.	9 from 10		



Soldering Profile Curve

Classification Reflow Profile (JEDEC J-STD-020C)

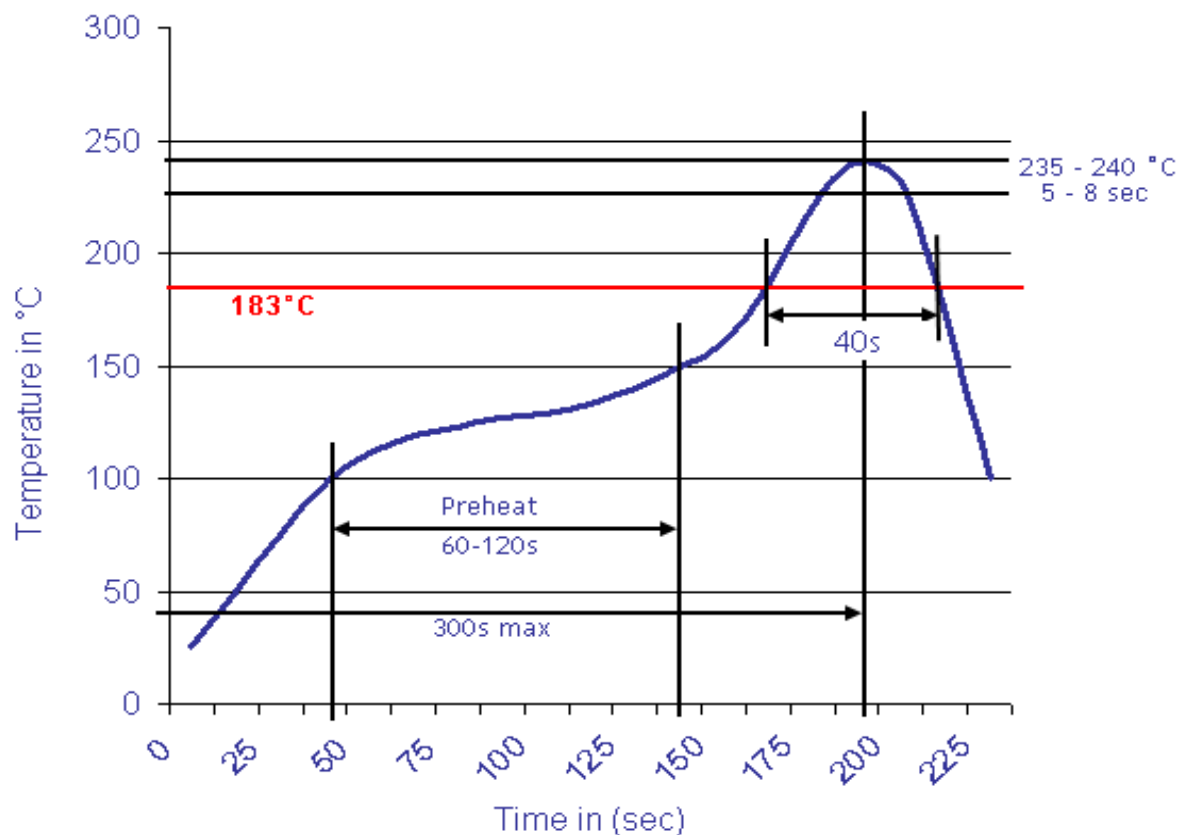

SUB-Miniature - Toogle Switch Type Solder Lug
Part No.: Q48A401
Customer:

DRW:	Jason	CHKD	Wilson	MATL:	Wilson	TOLERANCE	Mason	DATE	18.12.2015
APPD:	Schumi			FINISH	Jamy		Sheet No.	10 from 10	