

EDCON-COMPONENTS



SPECIFICATION:

Voltage Rating: 12VDC
 Current Rating: 50mA
 Mechanical Life: 500000 cycles
 Contact Resistance: <200m Ω max. (initial)
 Insulation Resistance: >100M Ω min. 500VDC
 Dielectric Strength: 100VAC/1min.
 Operating Temperature: -10°C ~ +60°C
 Operating Force: look Ordering Code

Drawing / Dimensions (mm)

PCB-Layout TOP VIEW

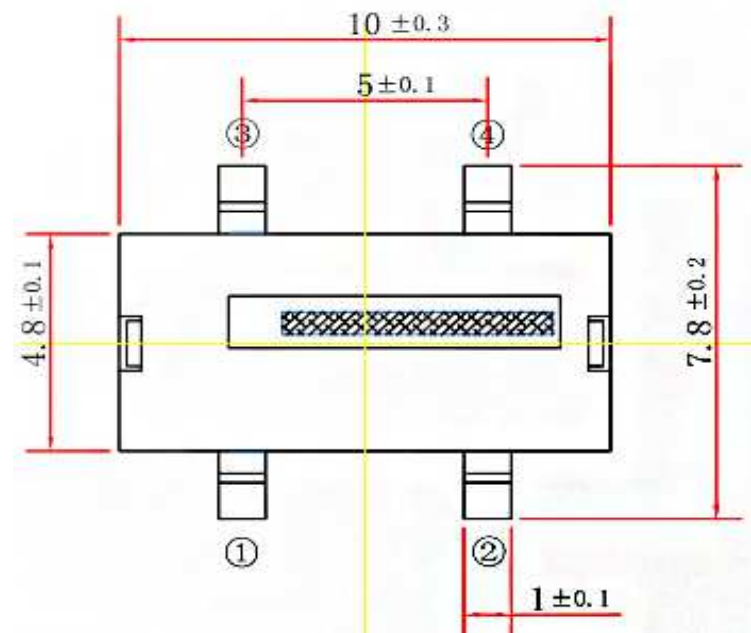
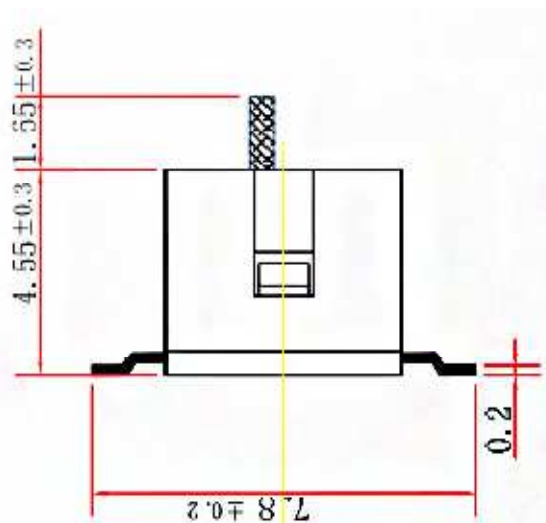
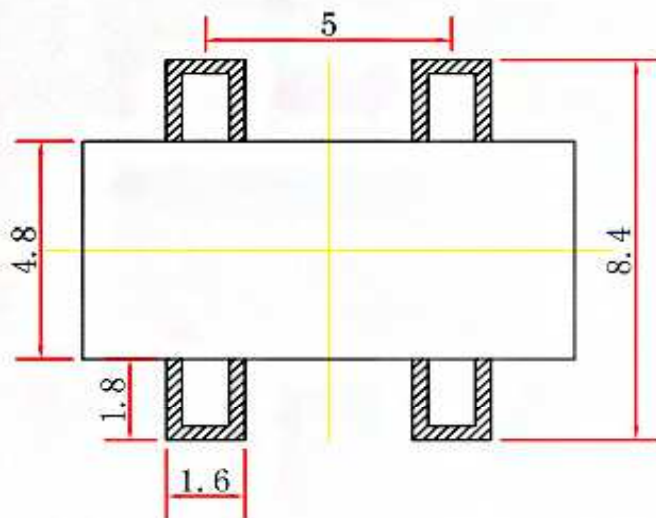

Tolerances unless otherwise specified (mm)

x	x.x	x.xx	x.xxx	Angle					
±	±	±	±	±3°					
DRW:	Jason	CHKD	Wilson	MATL:	Wilson	TOLERANCE	Mason	DATE	18.04.2021
APPD:	Schumi			FINISH	Jamy		Sheet No.		1 from 4

SMT Detector Switch

Part No.: **Q22014**

Customer:

EDCON-COMPONENTS



Circuit

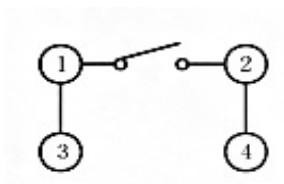

Drawing / Dimensions (mm)

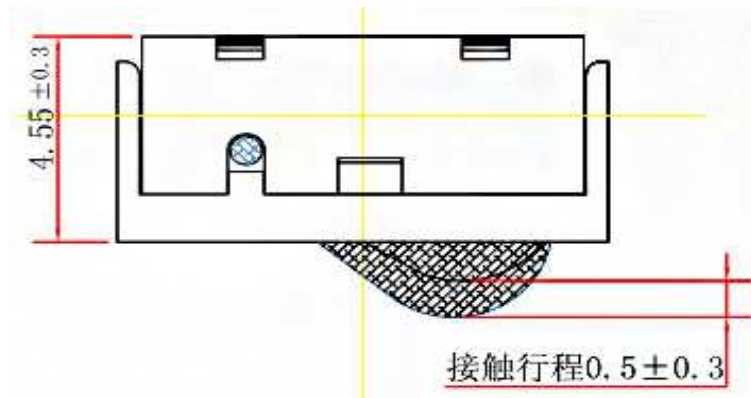

SMT Detector Switch

Part No.: **Q22014**

Customer:

DRW:	Jason	CHKD	Wilson	MATL:	Wilson	TOLERANCE	Mason	DATE	18.04.2021
APPD:	Schumi			FINISH	Jamy		Sheet No.	2 from 4	

EDCON-COMPONENTS



Ordering Informations

Serie	Total height w. Body	Fill with 0	Operating Force	Polarisation Peg	Electrical life	Cap Option	Cap Colour	Special function	ROHS	Packing
Q22014	045	X	050	Y	503	N	N	N	R	TR

050 = 5,0mm	X = no function	050 = 50gr	N = without Peg Y = with Peg	503 = 50000 Cycles	N = No Cap option	N = No Cap Option	N = No Function	N = Non ROHS	TR = Tape/Reel Packing TU = Tube Packing BU = Bulk Ware
--------------------	------------------------	-------------------	---	---------------------------	--------------------------	--------------------------	------------------------	---------------------	--

SMT Detector Switch	
Part No.:	Q22014
Customer:	

DRW:	Jason	CHKD	Wilson	MATL:	Wilson	TOLERANCE	Mason	DATE	18.04.2021
APPD:	Schumi			FINISH	Jamy		Sheet No.		3 from 4



Soldering Profile Lead Free Curve

Classification Reflow Profile (JEDEC J-STD-020C)

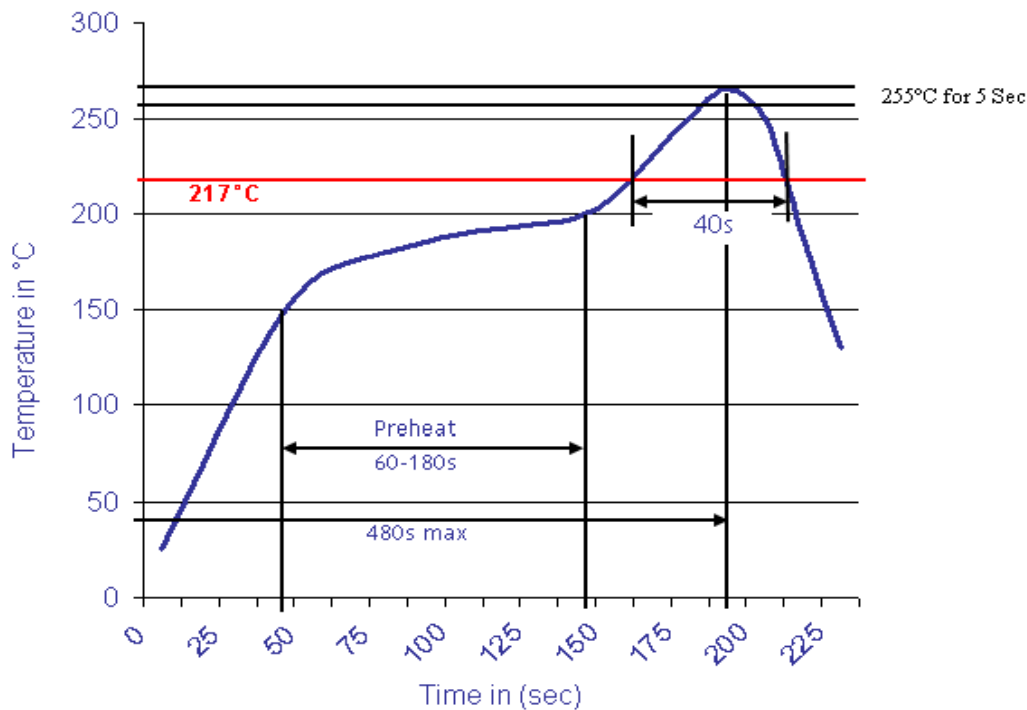

SMT Detector Switch

Part No.: **Q22014**

Customer:

DRW:	Jason	CHKD	Wilson	MATL:	Wilson	TOLERANCE	Mason	DATE	18.04.2021
APPD:	Schumi			FINISH	Jamy		Sheet No.	4 from 4	