

# EDCON-COMPONENTS



## SPECIFICATION:

Rated Voltage:	250VAC
Rated Current:	5A
Contact Resistance:	≤ 100mΩ / DC500V
Operating Force:	45gr +/- 20gr
Resilience:	RF
Free Position:(FP)	17,5 ± 1,2mm
Action Position:(OP)	15,5 ± 1,2mm
Return Position (RP)	
Stroke:	PT
Sensitivity:	BT
Mechanical:	
Mechanical Life:	1.000.000 cycles, 2,5 Welding Process Manual Welding
Electrical Life:	10.000 cycles
Applicable Temperature:	.-25°C + 85°C
Insulation Resistance:	≥100MΩ DC500V Applicable Humidity <85% RH
Withstanding Voltage:	AC 1000V 1 minute

## Drawing / Dimension (mm)

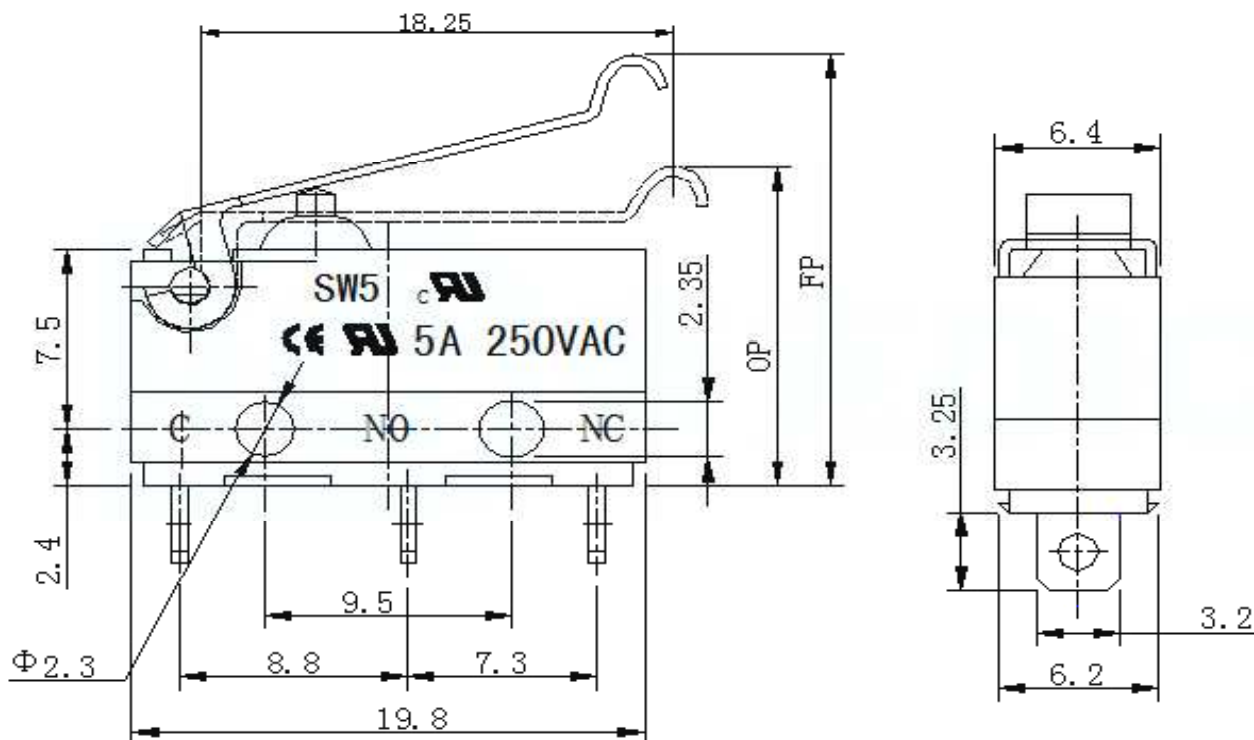

## SCHEMATIC

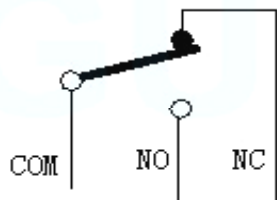

Tolerances unless otherwise specified (mm)				
x	x.x	x.xx	x.xxx	Angle
±	±	±	±	±3°
DRW:	Jason	CHKD	Wilson	MATL:
APPD:	Schumi			FINISH
				Jamy
				Mason
				DATE
				13.11.2021
				Sheet No.
				1 from 5

<b>THT Waterproof Mikro SWITCH 19,8x10,2mm</b>	
Part No.:	<b>Q19015</b>
Customer:	

# EDCON-COMPONENTS



## Technical Description

The test sample is installed in the dustproof box at the normal use position, and the test is carried out according to the second type of enclosure in GB4208-1993 (the pressure of the switch cavity is the same as the surrounding atmospheric pressure); the test should last for 8 hours, during which the switch should be turned on for 1 hour. Rated current and power-off for 1h; after the test, under the condition of ambient air temperature ( $25\pm 10^{\circ}\text{C}$ ), turn on the switch with rated current 5A 250VAC for temperature rise test

Take out the sample after 240h aging test in a heating box with an ambient temperature of ( $70\pm 2^{\circ}\text{C}$ ) immediately, and place it in a temperature of ( $25\pm 10^{\circ}\text{C}$ ) for at least 16h before conducting a waterproof test; clean water and test used in the test When the sample temperature difference is not more than 5K (no electricity during the test).

GB4208-1993/IEC60529-1989 "Enclosure Protection Grade" GB15092.1-2003/IEC61058-1:1996 "Appliance Switch Part 1: General Requirements" Environmental conditions: temperature range  $15^{\circ}\text{C}$ - $35^{\circ}\text{C}$ ; relative humidity 25%-75%.

After the test, the switch should meet the following requirements: the sealing rubber cap and the switch body must not be deformed, damaged, hardened and other aging phenomena; there should be no water marks on the plastic parts of the switch that reduce the creepage distance and electrical clearance below the standard value; between the terminals And the terminal and the outer surface of the shell withstand voltage strength  $\geq 1000\text{V}$

After the test, the switch should meet:

1. The action is normal;
2. Temperature rise test  $\leq 50\text{K}$ ;
3. Withstand voltage strength between the terminals and between the terminals and the outer surface of the shell  $\geq 1000\text{V}$

					Tolerances unless otherwise specified (mm)					THT Waterproof Mikro SWITCH 19,8x10,2mm
					x	x.x	x.xx	x.xxx	Angle	
					±	±	±	±	±3°	Part No.: <b>Q19015</b>
DRW:	Jason	CHKD	Wilson	MATL:	Wilson	TOLERANCE	Mason	DATE	13.11.2021	Customer:
APPD:	Schumi			FINISH	Jamy		Sheet No.	2 from 5		

# EDCON-COMPONENTS



## Lever Style (Ax)

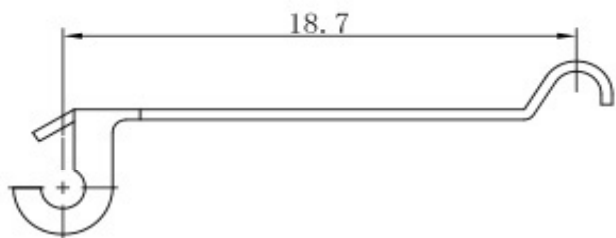

Order Code = A1

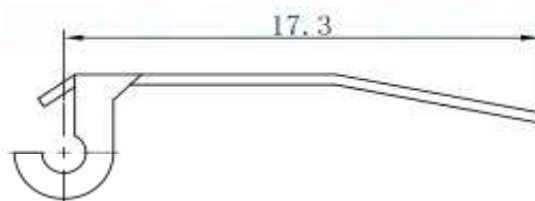

Order Code = A4

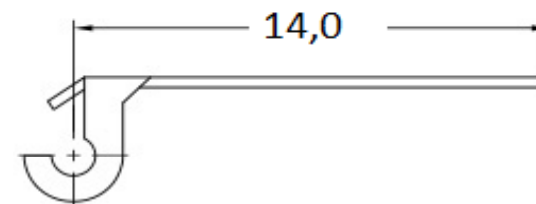

Order Code = A7

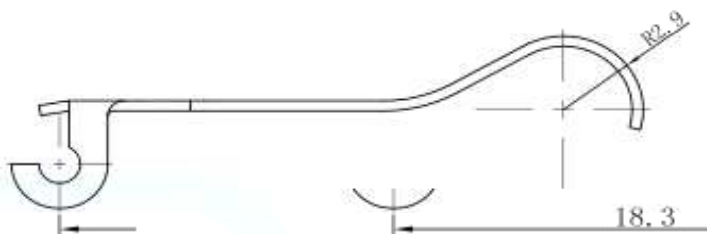

Order Code = A2

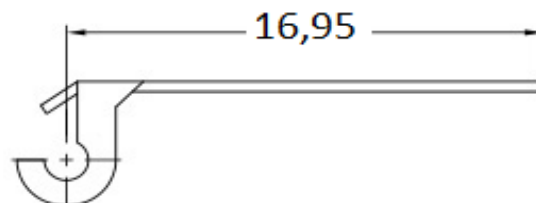

Order Code = A5

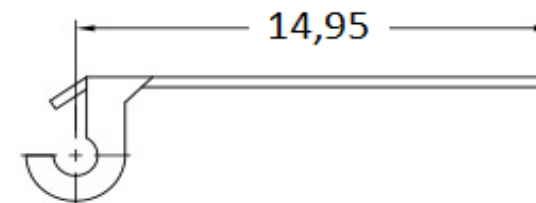

Order Code = A8

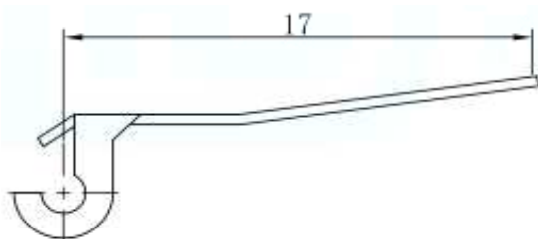

Order Code = A3

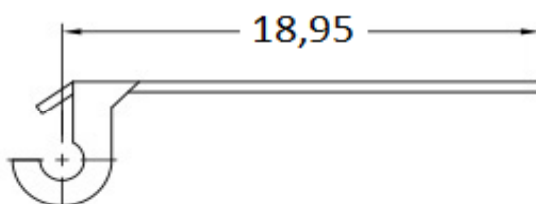

Order Code = A6

Order Code	Operating Force (gf)		
	OF		
B0	115		
B1	150		
B2	175		
B3	190		
B4	220		
B5	250		

**THT Waterproof Mikro SWITCH 19,8x10,2mm**

Part No.: **Q19015**

Customer:

DRW:	Jason	CHKD	Wilson	MATL:	Wilson	TOLERANCE	Mason	DATE	13.11.2021
APPD:	Schumi			FINISH	Jamy		Sheet No.		3 from 5

[www.edcon-components.com](http://www.edcon-components.com)

email: [info@edcon-components.com](mailto:info@edcon-components.com)

# EDCON-COMPONENTS



## Ordering Informations

Serie	Switch Type	Lever Style Code (Ax)	Operating force (Bx)	Special function	Special function	ROHS	Packing
<b>Q19015</b>	<b>1</b>	<b>A0</b>	<b>Bx</b>	<b>C0</b>	<b>D0</b>	<b>R</b>	<b>BU</b>

<b>1= 10A/125/250VAC</b>	<b>A0= without Lever</b>	<b>B0= 115gr</b>	<b>C0= No function</b>	<b>D0= No function</b>	<b>R= ROHS conform</b>	<b>BU= Bulk Ware</b>
	<b>A1= Type A1</b>	<b>B1= 150gr</b>			<b>N= Non ROHS</b>	<b>TY= Tray Packing</b>
	<b>A2= Type A2</b>	<b>B2= 175gr</b>				
	<b>A3= Type A3</b>	<b>B3= 190gr</b>				
	<b>A4= Type A4</b>	<b>B4= 220gr</b>				<b>IV= Individual Packing</b>
	<b>A5= Type A5</b>	<b>B3= 250gr</b>				
	<b>A6= Type A6</b>					
	<b>A7= Type A7</b>					
	<b>A8= Type A8</b>					

**THT Waterproof Mikro SWITCH 19,8x10,2mm**

Part No.: **Q19015**

Customer:

DRW:	Jason	CHKD	Wilson	MATL:	Wilson	TOLERANCE	Mason	DATE	13.11.2021
APPD:	Schumi			FINISH	Jamy		Sheet No.		4 from 5



Soldering Profile for Lead Free Soldering

Soldering Profile for Reflow Soldering

## Classification Reflow Profile (JEDEC J-STD-020C)

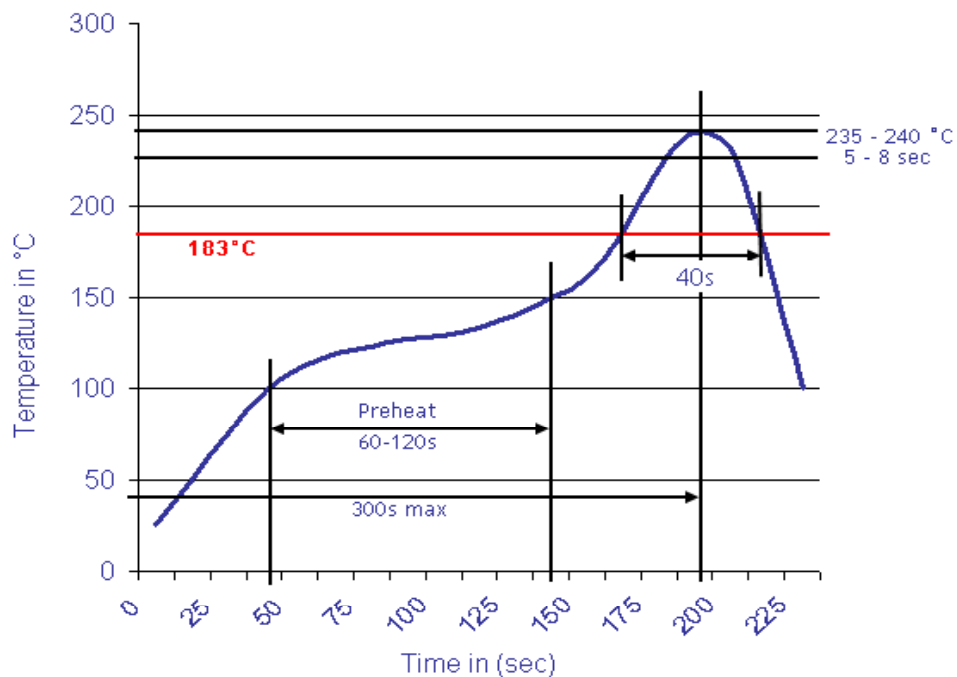

**THT Waterproof Mikro  
SWITCH 19,8x10,2mm**

Part No.: **Q19015**

Customer:

DRW:	Jason	CHKD	Wilson	MATL:	Wilson	TOLERANCE	Mason	DATE	13.11.2021
APPD:	Schumi			FINISH	Jamy		Sheet No.		5 from 5