

EDCON-COMPONENTS



Technical Informations

Material: Nylon 66
 Flame Class: 94V-2 / V0
 Color: Natural
 Temperature Range: -40°C ~ +85°C

Hole Diameter

Hole 1 (+/-0,08mm) 8~10mm Screw
 Hole 1 (+/-0,08mm) 6,6x7,8mm

Dimension (mm)

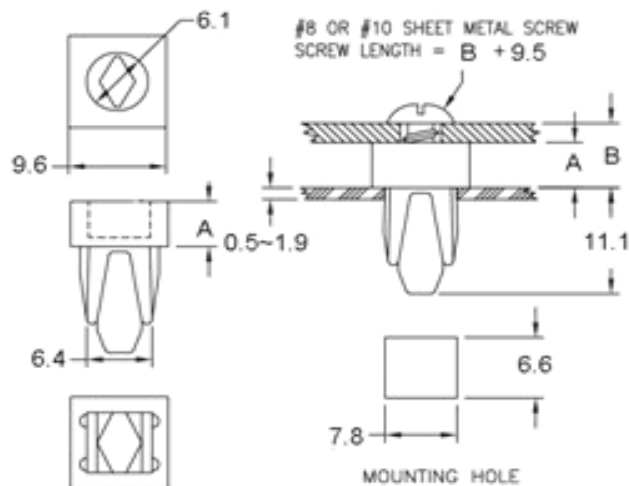

Ordering Code table

Order Code	A			
A01	0,8			
A02	1,6			
A03	3,2			
A04	4,8			
A05	6,4			
A06	7,9			
A07	9,5			
A08	11,1			
A09	12,7			
A10				
A11				
A12				
A13				
A14				
A15				
A16				
A17				
A18				
A19				
A20				
A21				
A22				
A23				
A24				
A25				
A26				
A27				

Spacer Nut

Part No.: **N17129**

Customer:

DRW:	Jason	CHKD	Wilson	MATL:	Wilson	TOLERANCE	Mason	DATE	15.02.2013
APPD:	Schumi			FINISH	Jamy		Sheet No.	1 from 2	

EDCON-COMPONENTS



Ordering Informations

Serie	Order Code table	Material	Color	ROHS	Packing					
N17129	A01	NY	WH	R	BU					

A01= Length	NY= Nylon	WH= White	R= ROHS Conform	BU= Bulk-Ware					
			N= NON ROHS Conform	IV= Individual Packing					

Spacer Nut	
Part No.:	N17129
Customer:	

DRW:	Jason	CHKD	Wilson	MATL:	Wilson	TOLERANCE	Mason	DATE	15.02.2013
APPD:	Schumi			FINISH	Jamy			Sheet No.	2 from 2