

EDCON-COMPONENTS



Technical Informations

Material: Nylon 66 + TPE
 Flame Class: 94V-2 / V2
 Color: Natural
 Temperature Range: -40°C ~ +85°C

Hole Diameter

Hole 1 (+/-0,08mm) 4,8mm
 Panel Thickness Hole 1 0,8 ~ 2,0mm
 Hole 2 (+/-0,08mm) 4,8mm
 Panel Thickness Hole 2 0,8 ~ 2,0mm

Dimension (mm)

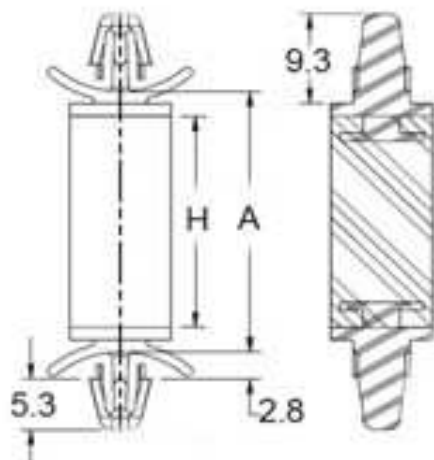

Ordering Code table

Order Code	A	H		
A01	14,9	9,7		
A02	21,0	16,3		
A03	27,1	22,0		
A04	33,2	28,0		
A05				
A06				
A07				
A08				
A09				
A10				
A11				
A12				
A13				
A14				
A15				
A16				
A17				
A18				
A19				
A20				
A21				
A22				
A23				
A24				
A25				
A26				
A27				

Double Arrow High Shock Board Spacer

Part No.: **N17100**

Customer:

DRW:	Jason	CHKD	Wilson	MATL:	Wilson	TOLERANCE	Mason	DATE	08.02.2013
APPD:	Schumi			FINISH	Jamy		Sheet No.		1 from 2

EDCON-COMPONENTS



Ordering Informations

Serie	Order Code table	Material	Color	ROHS	Packing					
N17100	A01	NY	WH	R	BU					

A01= Length	NY= Nylon	WH= White	R= ROHS Conform	BU= Bulk-Ware					
			N= NON ROHS Conform	IV= Individual Packing					

Double Arrow High Shock Board Spacer	
Part No.:	N17100
Customer:	

DRW:	Jason	CHKD	Wilson	MATL:	Wilson	TOLERANCE	Mason	DATE	08.02.2013
APPD:	Schumi			FINISH	Jamy			Sheet No.	2 from 2