

EDCON-COMPONENTS



Technical Informations

Material: Nylon 66
 Flame Class: 94V-2 / V0
 Color: Natural
 Temperature Range: -40°C ~ +85°C

Hole Diameter

Hole 1 (+/-0,08mm)
 Panel Thickness Hole 1
 Hole 2 (+/-0,08mm) 3,0mm
 Panel Thickness Hole 2 1,2~1,7mm

Dimension (mm)

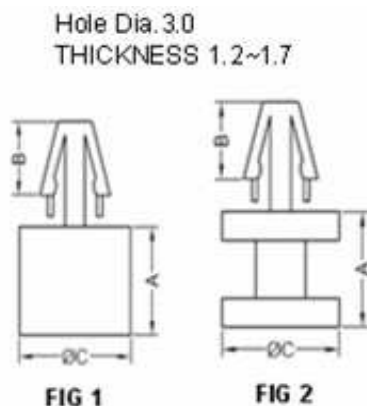

Ordering Code table

Order Code	A	B	C	Fig.
A01	2,0	4,0	6,5	1
A02	2,5	4,0	6,5	1
A03	3,0	4,0	6,8	1
A04	3,5	4,0	6,8	1
A05	4,0	4,0	6,8	1
A06	5,0	4,0	6,0	2
A07	5,7	4,0	6,9	2
A08	6,0	4,0	6,8	2
A09	6,5	4,0	6,0	2
A10	7,0	4,0	6,0	2
A11	8,0	4,0	6,8	2
A12	10,0	4,0	6,8	2
A13	15,0	4,0	6,0	2
A14				
A15				
A16				
A17				
A18				
A19				
A20				
A21				
A22				
A23				
A24				
A25				
A26				
A27				

**Arrow Push Locking
 Circuit Board Spacer**

Part No.: **N17048**

Customer:

DRW:	Jason	CHKD	Wilson	MATL:	Wilson	TOLERANCE	Mason	DATE	05.02.2013
APPD:	Schumi			FINISH	Jamy		Sheet No.		1 from 2

EDCON-COMPONENTS



Ordering Informations

Serie	Order Code table	Material	Color	ROHS	Packing					
N17048	A01	NY	WH	R	BU					

A01= Length	NY= Nylon	WH= White	R= ROHS Conform	BU= Bulk-Ware					
			N= NON ROHS Conform	IV= Individual Packing					

Arrow Push Locking Circuit Board Spacer	
Part No.:	N17048
Customer:	

DRW:	Jason	CHKD	Wilson	MATL:	Wilson	TOLERANCE	Mason	DATE	05.02.2013
APPD:	Schumi			FINISH	Jamy			Sheet No.	2 from 2