

Data Sheet

Wafer Dual Row Straight Terminal Block THR 2,60mm

Pitch: 3,50 mm

Serie: A14G126

Customer Information for special Item

EDCON Customer : xxxxxx

Customer Version No. : xx

EDCON-COMPONENTS



Technical Discription

技术数据-UL/CUL

等级 Use Group	B	C	D
额定电压 Rate Voltage [V]	300	-	-
额定电流 Rated Current [A]	8	-	-
接线范围 Wire Range [AWG]	/		
耐电压 Dielectric Voltage-Withstand	1.6KV		

技术参数-IEC

过电压类别 Overvoltage Category	III	III	II
污染等级 Contamination Class	3	2	2
额定电压 Rated Voltage [V]	160	160	250
额定电流 Rated Current [A]	8	8	8
额定冲击电压 Impulse withstand voltage [KV]	2.5	2.5	2.5
导线截面积(硬/柔) Conductor cross section [mm²]	/		

材料 Material

绝缘材料 Insulation Material	LCP
阻燃等级 Flame relardant rating	UL94V-0
导体材料 Conductor Material	Copper alloy
导体表面镀层 Plating of conductor surface	Sn plated

一般参数 Other Data

间距/极数 Pitch/Poles [mm]/[P]	3.5 , 3.81/2*2-2*24
剥线长度 Stripping Length [mm]	/
螺丝/扭矩 Screw/Torque(Max)[N.m]	/
工作温度 Operating temperature [°C]	-40~+130
焊锡温度 Soldering temperature	285°C/10S
引针尺寸 Pin dimensions [mm]	0.8*0.8
PCB板孔径 PCB Hole Diameter [mm]	Ø1.4

Drawing (Dimension in mm)

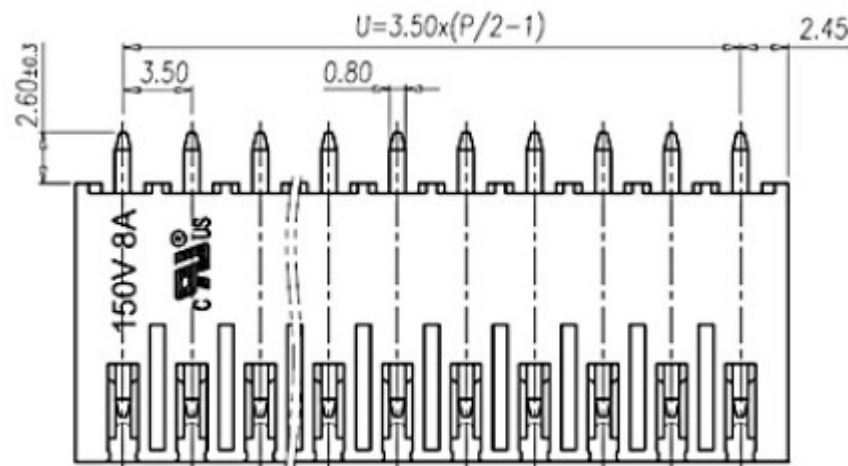

DRW:	Jason	CHKD:	Wilson	MATL:	Wilson
APPD:	Schumi			FINISH:	Jamy

Tolerances unless otherwise specified (mm)				
X	X.X	X.XX	X.XXX	Angle
±	±	±	±	±3°
Sheet No.			03.05.2026	
Sheet No.			1 from 4	

Wafer Dual Row Straight Terminal Block THR 2,60mm	
Part No.:	A14G126
Customer:	

www.edcon-components.com

email: info@edcon-components.com

EDCON-COMPONENTS



Drawing (Dimension in mm)

PCB Layout (unit /mm) PCB View

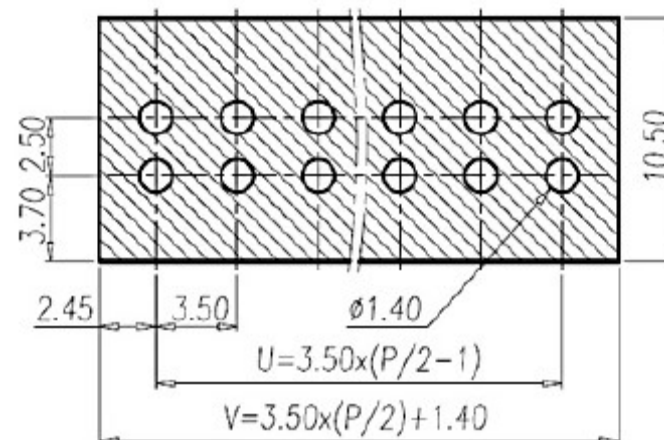
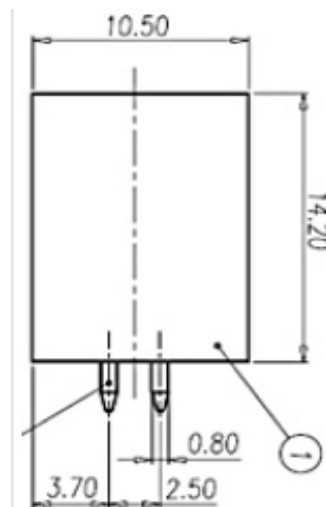
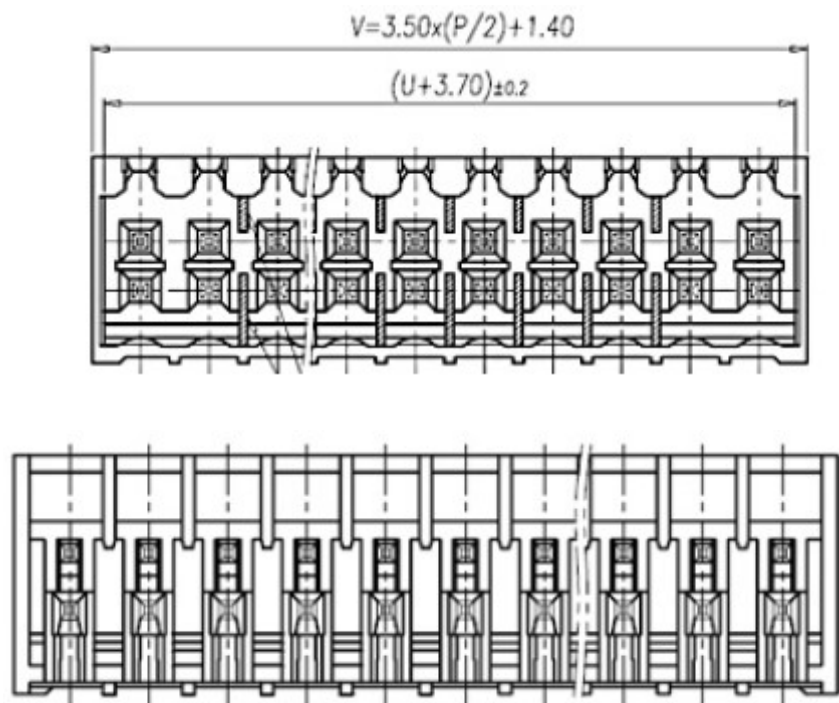

Wafer Dual Row Straight Terminal Block THR 2,60mm	
Part No.:	A14G126
Customer:	

DRW:	Jason	CHKD:	Wilson	MATL:	Wilson	TOLERANCE:	Mason	DATE:	03.05.2026
APPD:	Schumi			FINISH:	Jamy		Sheet No.		2 from 4

www.edcon-components.com

email: info@edcon-components.com

EDCON-COMPONENTS



Ordering Informations

Serie	No. of Pos.	Body Color	Special function	Approval Code	ROHS	Packing	EDCON Cust. No.	Customer Version		
A14G126	04	BK	N	N	R	B	xxxxxx	xx		

Pitch
3,50

02= Number of Pos.2x2P		N= No special function	N= NON Approval	R= ROHS Conform	B= Bulk-Ware	xxxxxx= Customer Number	xx= Customer Version ??(Printing)
Standard 2x2 ~ 2x24Pos.			1= UL-Approval for Material	N= NON ROHS Conform	I= Individual Package		
			A= UL /UR Approval Please consult EDCON for available				
	BK= Black		B= VDE Approval Please consult EDCON for available				
			C= TÜV Approval Please consult EDCON for available				

Wafer Dual Row Straight Terminal Block THR 2,60mm	
Part No.:	A14G126
Customer:	

DRW:	Jason	CHKD	Wilson	MATL:	Wilson	TOLERANCE	Mason	DATE	03.05.2026
APPD:	Schumi			FINISH	Jamy		Sheet No.		3 from 4



Soldering Profile

Classification Reflow Profile (JEDEC J-STD-020C)

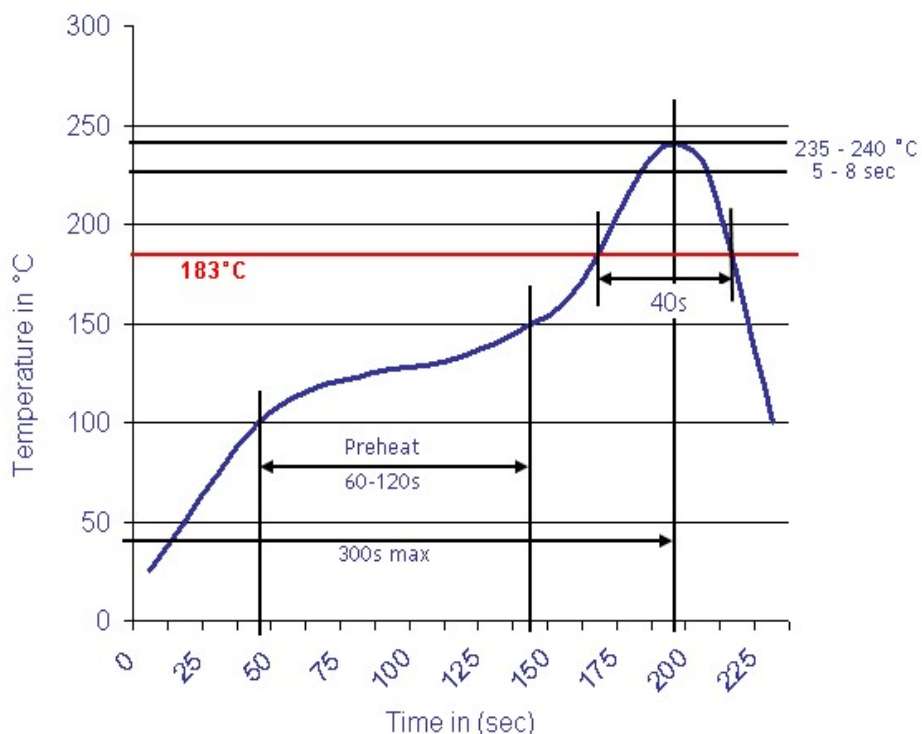

Classification Reflow Profile (JEDEC J-STD-020C)

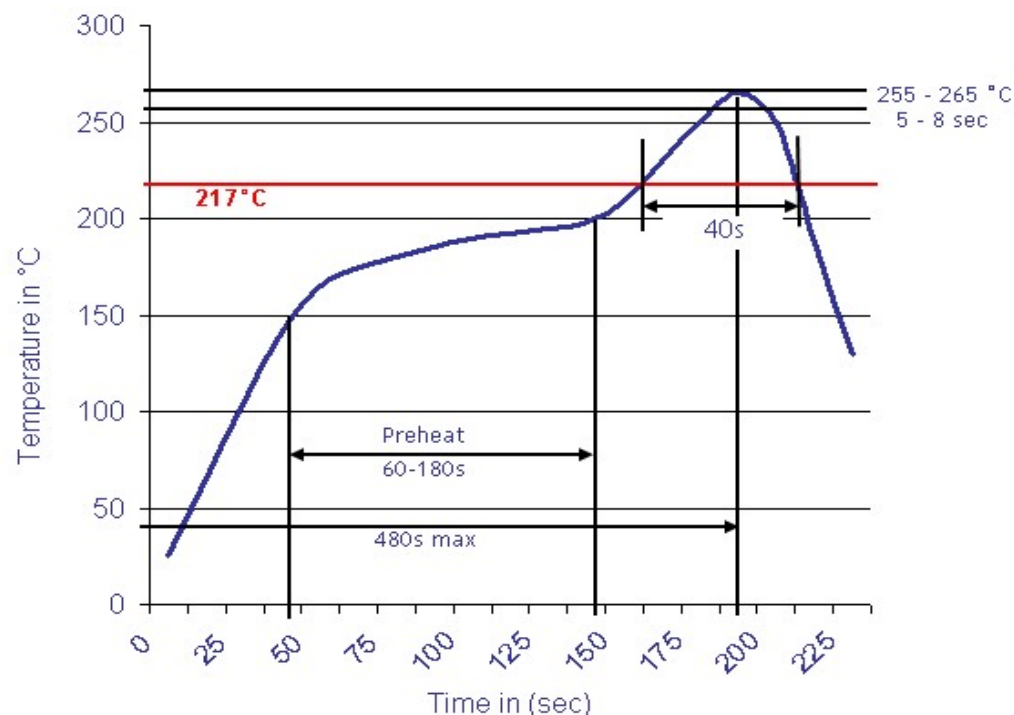

Wafer Dual Row Straight Terminal Block THR 2,60mm	
Part No.:	A14G126
Customer:	

DRW:	Jason	CHKD	Wilson	MATL:	Wilson	TOLERANCE	Mason	DATE	03.05.2026
APPD:	Schumi			FINISH	Jamy		Sheet No.		4 from 4