

# EDCON-COMPONENTS

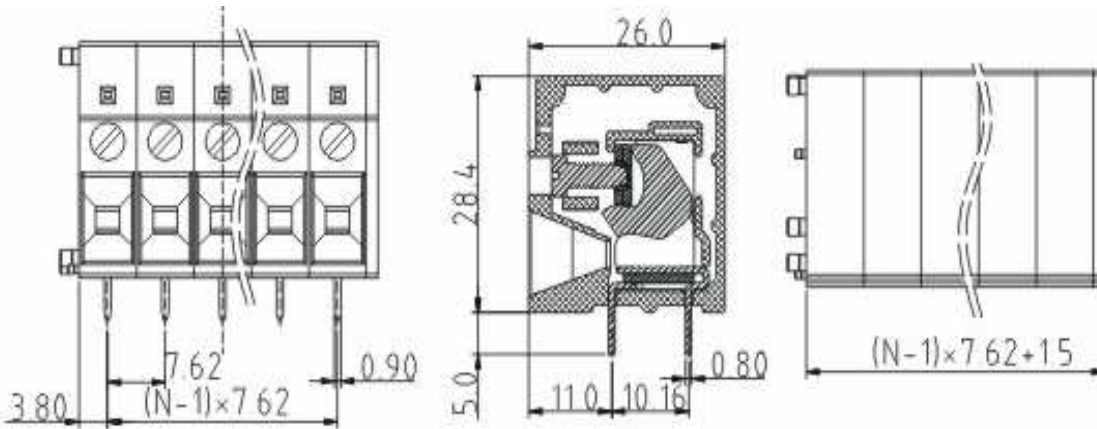

## Drawing



## P.C.B. Layout

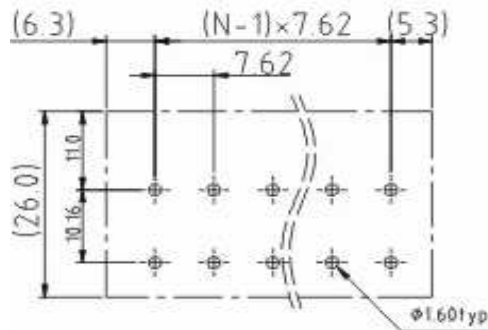

## Specification

### APPLYING APPROVAL



#### Electrical

Standard	cULus
Rated voltage	300V
Rated current	30A
Wire range	24-10 AWG
Withstanding voltage	1.6KV

#### Mechanical

Ambient temperature	-40°C ~ +115°C
Soldering temperature	250°C ± 10°C/5 sec
Strip length	15 ~ 16mm
Screw, Torque	M3, 0.4Nm (4.3Lb-In.)

#### Dimensions

Pitch	7.62mm
Poles	2P - 16P

#### Material

Housing	Thermoplastic (UL94V-0)
Surface of solder tail	Tin plated
Contact	Brass
Terminal screw	Steel Zinc plated
Metal housing	Steel stamped



Wire Protector Terminal Block /  
Pitch 7.62mm

Part No.: A12R004

Customer:

DRW:	Bill	CHKD	Lord	MATL:	Jimmy	TOLERANCE	Sam	DATE	15.03.2009
APPD:	Louis			FINISH	Georg			Sheet No.	1 from 3

[www.edcon-components.com](http://www.edcon-components.com)

email: [info@edcon-components.com](mailto:info@edcon-components.com)

# EDCON-COMPONENTS



## Ordering Informations

Serie	-	No. of Pole	Body-Color	wire protector	Screw	-	Customer Request
A12R004	-	XX	XX	X	X	-	X

XX = total	WH - white	1 - with wire protector	A - Slotted screw (standard)
	GN - green	2 - without wire protector	B - Cross-slotted screw
	GR - gray		
	LG - light gray		
	PG - Phoenix Green		
	OR - orange		
BL - blue			
BK - black			

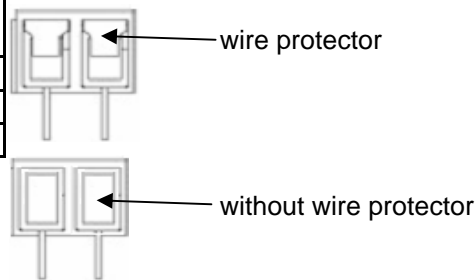

**Certification**



Wire Protector Terminal Block / Pitch 7.62mm
Part No.: A12R004
Customer:

DRW:	Bill	CHKD	Lord	MATL:	Jimmy	TOLERANCE	Sam	DATE	15.03.2009
APPD:	Louis			FINISH	Georg		Sheet No.		2 from 3

[www.edcon-components.com](http://www.edcon-components.com)

email: [info@edcon-components.com](mailto:info@edcon-components.com)



## Soldering - Profil

Classification Reflow Profile (JEDEC J-STD-020C)

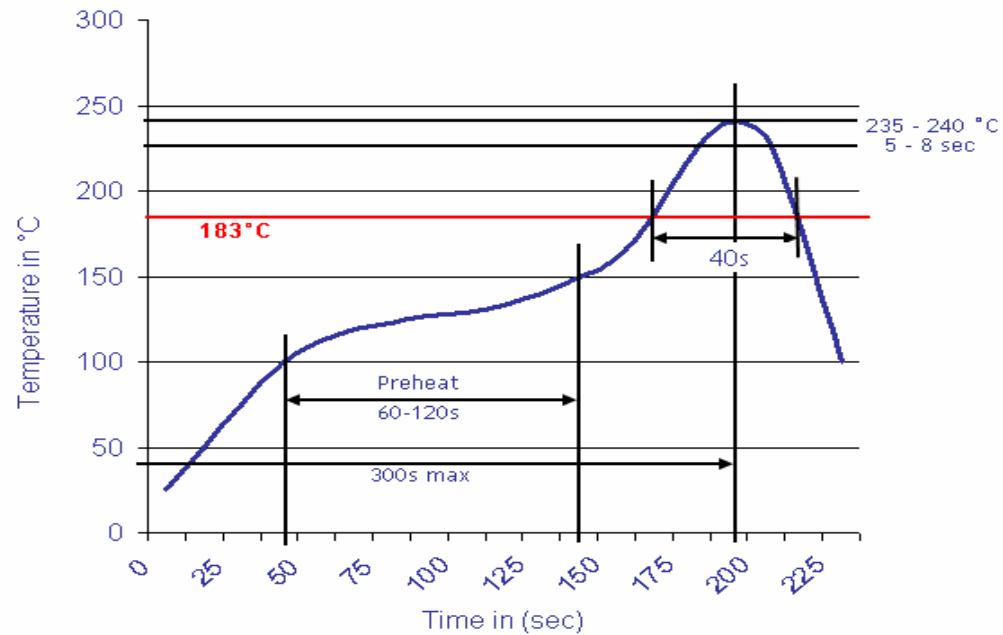

Wire Protector Terminal Block /  
Pitch 7.62mm

Part No.: A12R004

DRW:	Bill	CHKD	Lord	MATL:	Jimmy	TOLERANCE	Sam	DATE	15.03.2009
APPD:	Louis			FINISH	Georg		Sheet No.	3 from 3	

Customer: