

EDCON-COMPONENTS

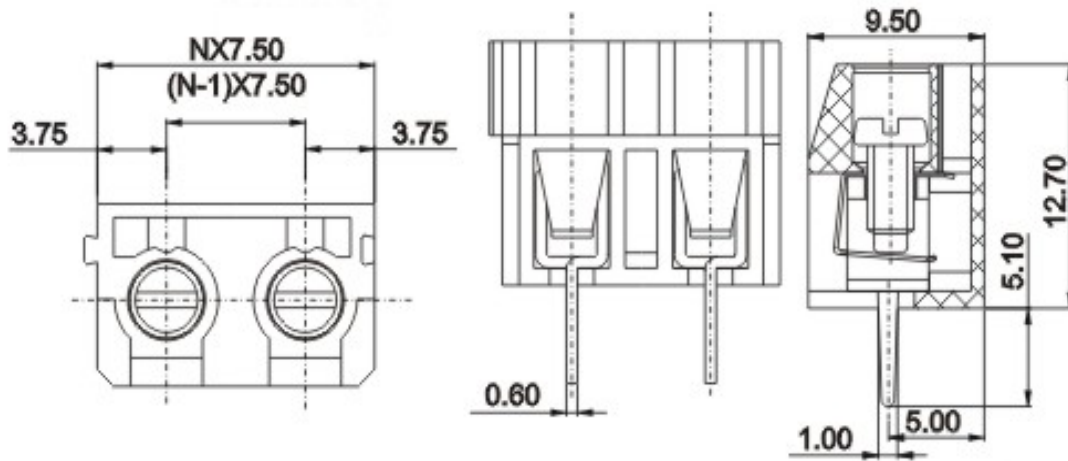

Drawing



P.C.B. Layout

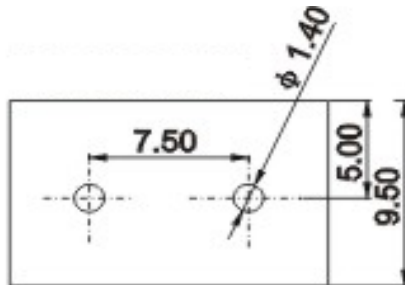

Specification

APPROVAL



Electrical

Standard
Rated voltage
Rated current
Wire range
Withstanding voltage

UL	IEC
300V	450V
15A	20A
22-14 AWG	2.5mm ²
AC2500V/1Min	

Mechanical

Ambient temperature
Strip length
Screw, Torque

-30°C ~ +120°C
5 ~ 6mm
M2.5, 0.4Nm (3.5Lb-In.)

Dimensions

Pitch
Poles

7.50mm
2P, 3P-24P

Material

Housing
Pin header
Screw
Wire guard

PBT (UL94V-0)
Brass, Tin plated
steel, Cr³⁺ Zn plated
Stainless steel



Certification



Wire Protector Terminal Block /
Pitch 7.50mm

Part No.: A12Q004

Customer:

DRW:	Bill	CHKD	Lord	MATL:	Jimmy	TOLERANCE	Sam	DATE	14.3.2009
APPD:	Louis			FINISH	Georg			Sheet No.	1 from 3

www.edcon-components.com

email: info@edcon-components.com

EDCON-COMPONENTS



Ordering Informations

Serie	-	No. of Pole	Body-Color	wire protector	Screw	-	Customer Request
A12Q004	-	XX	XX	X	X	-	X

XX = total	WH - white	1 - with wire protector	A - Slotted screw (standard)
	GN - green	2 - without wire protector	B - Cross-slotted screw
	GR - gray		
	BL - blue		



PG - Phoenix Green
OR - orange
LG - light gray
BK - black

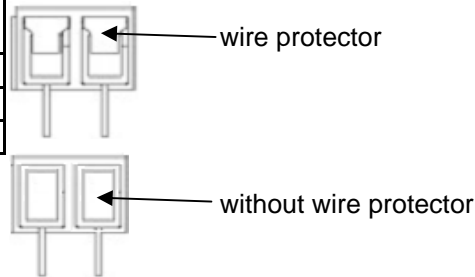

Certification



Wire Protector Terminal Block / Pitch 7.50mm	
Part No.:	A12Q004
Customer:	

DRW:	Bill	CHKD	Lord	MATL:	Jimmy	TOLERANCE	Sam	DATE	14.3.2009
APPD:	Louis			FINISH	Georg			Sheet No.	2 from 3

www.edcon-components.com

email: info@edcon-components.com



Soldering - Profil

Classification Reflow Profile (JEDEC J-STD-020C)

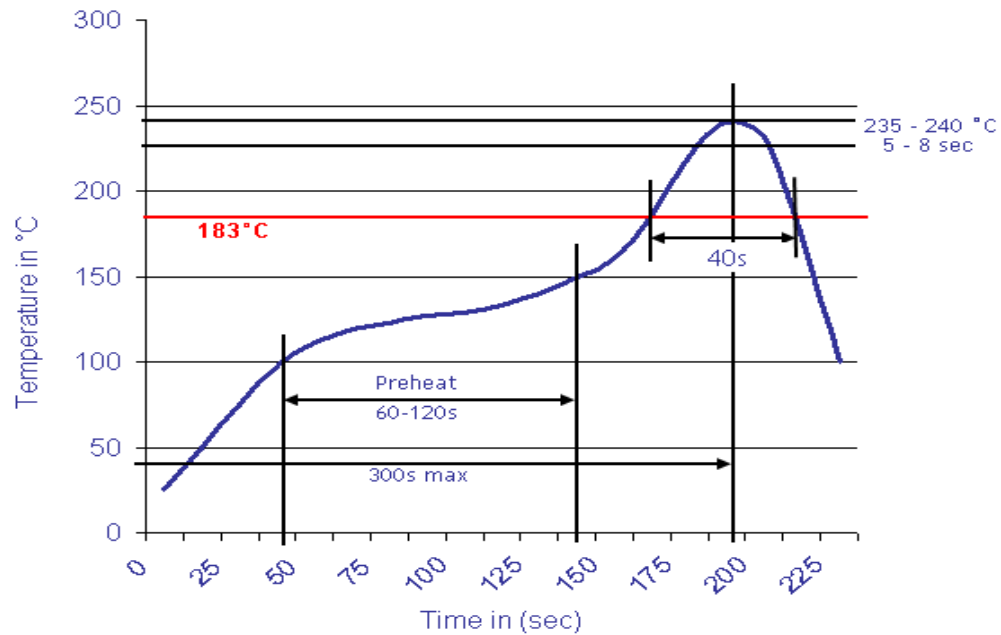

Wire Protector Terminal Block /
Pitch 7.50mm

Part No.: A12Q004

DRW:	Bill	CHKD	Lord	MATL:	Jimmy	TOLERANCE	Sam	DATE	14.3.2009	Customer:
APPD:	Louis			FINISH	Georg		Sheet No.	3 from 3		