

EDCON-COMPONENTS

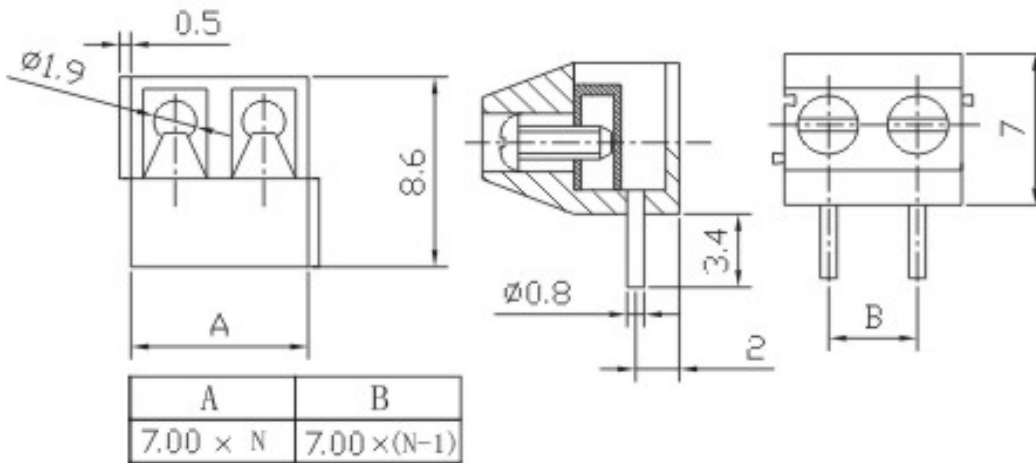

Drawing



P.C.B. Layout

Specification

Electrical

Rated voltage	300V
Rated current	7A
Wire range	24-18AWG / 1.0mm ²
Contact resistance	20mΩ
Withstanding voltage	AC 2000V/1Min
Insulation resistance	5000MΩ/DC1000V

Mechanical

Ambient temperature	-40°C ~ +105°C
Strip length	4,5 ~ 5mm
Screw, Torque	M2, 0.2Nm (1.7Lb-In.)

Dimensions

Pitch	7.00mm
Poles	2P + 3P

Material

Housing	PA66 (UL94V-0)
Pin header	Brass, Tin-plated
Screw	steel, Zinc-plated
Wire guard	Phosphor Bronze, Ni-plated



Wire Protector Terminal Block /
Pitch 7.00mm

Part No.: A12P002

Customer:

DRW:	Bill	CHKD	Lord	MATL:	Jimmy	TOLERANCE	Sam	DATE	15.3.2009
APPD:	Louis			FINISH	Georg			Sheet No.	1 from 3

www.edcon-components.com

email: info@edcon-components.com

EDCON-COMPONENTS



Ordering Informations

Serie	-	No. of Pole	Body-Color	wire protector	Screw	-	Customer Request
A12P002	-	XX	XX	X	X	-	X

XX = total	WH - white	1 - with wire protector	A - Slotted screw (standard)
	GN - green	2 - without wire protector	B - Cross-slotted screw
	GR - gray		
	LG - light gray		
	PG - Phoenix Green		
	OR - orange		
	BL - blue		
	BK - black		

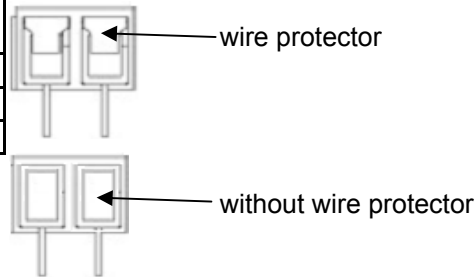

Wire Protector Terminal Block /
Pitch 7.00mm

Part No.: A12P002

Customer:

DRW:	Bill	CHKD	Lord	MATL:	Jimmy	TOLERANCE	Sam	DATE	15.3.2009
APPD:	Louis			FINISH	Georg			Sheet No.	2 from 3

EDCON-COMPONENTS



Soldering - Profil

Classification Reflow Profile (JEDEC J-STD-020C)

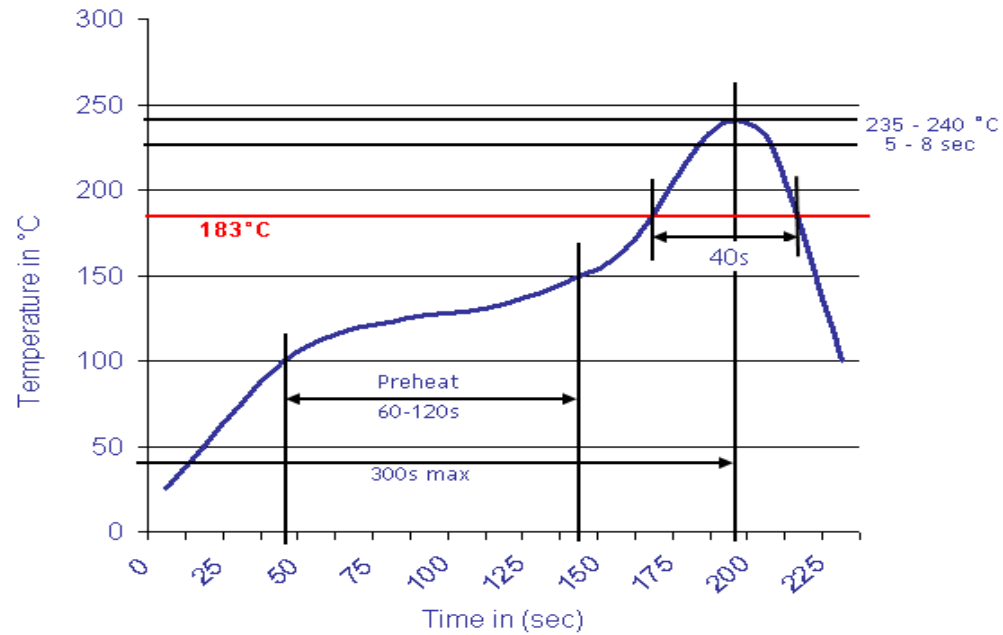

Wire Protector Terminal Block /
Pitch 7.00mm

Part No.: A12P002

DRW:	Bill	CHKD	Lord	MATL:	Jimmy	TOLERANCE	Sam	DATE	15.3.2009
APPD:	Louis			FINISH	Georg		Sheet No.	3 from 3	

Customer: