

EDCON-COMPONENTS

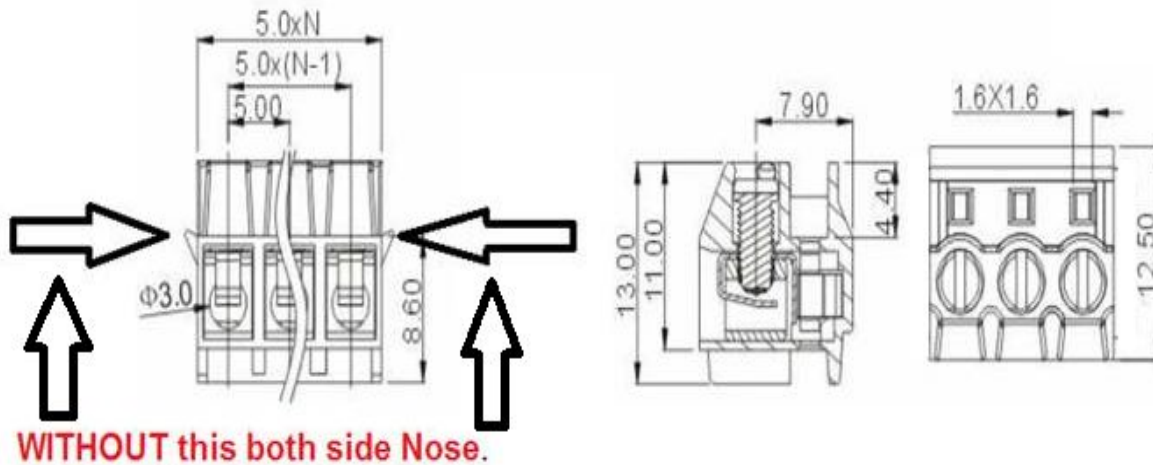

Drawing



P.C.B. Layout

Specification

Electrical

Standard	UL	IEC
Rated voltage	300V	250V
Rated current	10A	12A
Wire range	28-14 AWG	2.5mm ²
Withstanding voltage	AC2000V/1Min	

Mechanical

Ambient temperature	-40°C ~ +105°C
Strip length	5 ~ 6mm
Screw, Torque	M2.5, 0.4Nm (3.5Lb-In.)

Dimensions

Pitch	5.00mm
Poles	2P - 20P

Material

Housing	PA66 (UL94V-0)
Contact	Phosphor Bronze
Screw	steel, Cr ³⁺ Zn plated
Cage	Brass, Ni plated

Wire Protector Terminal Block / Pitch 5.00mm	
Part No.:	A12L081
Customer:	

DRW:	Bill	CHKD	Lord	MATL:	Jimmy	TOLERANCE	Sam	DATE	25.11.2022
APPD:	Louis			FINISH	Georg		Sheet No.		1 from 2

www.edcon-components.com

email: info@edcon-components.com

EDCON-COMPONENTS



Ordering Informations

Serie	-	No. of Pole	Body-Color	wire protector	Screw	-	Customer Request
A12L081	-	XX	XX	X	X	-	X

XX = total	WH - white	1 - with wire protector	A - Slotted screw (<i>standard</i>)
	GN - green	2 - without wire protector	B - Cross-slotted screw
	GR - gray		
	LG - light gray		
	PG - Phoenix Green		
	OR - orange		
	BL - blue		
	BK - black		

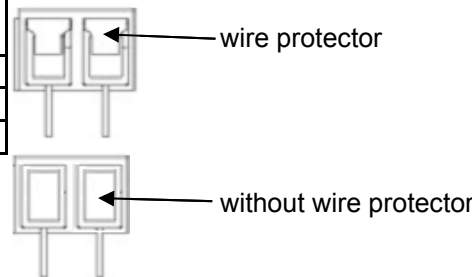

Wire Protector Terminal Block / Pitch 5.00mm	
Part No.:	A12L081
Customer:	

DRW:	Bill	CHKD	Lord	MATL:	Jimmy	TOLERANCE	Sam	DATE	25.11.2022
APPD:	Louis			FINISH	Georg			Sheet No.	2 from 2