

# EDCON-COMPONENTS

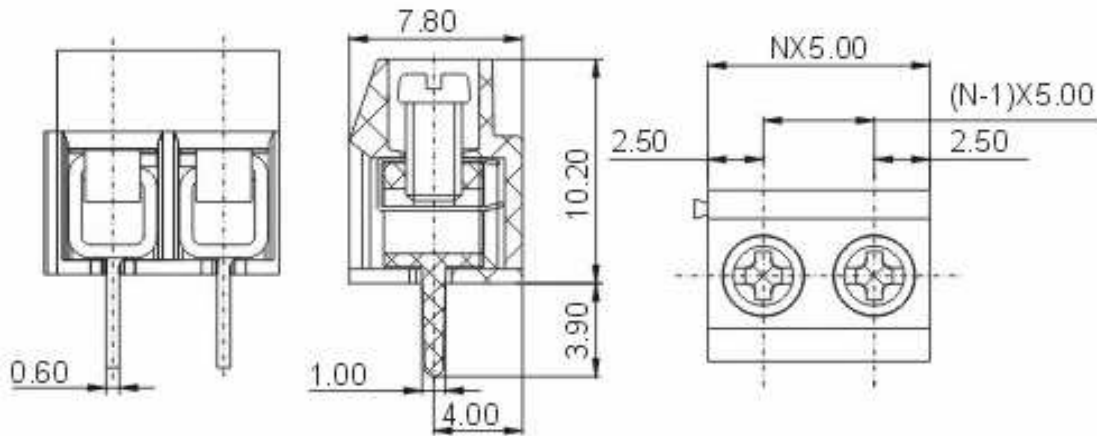

## Drawing



## P.C.B. Layout

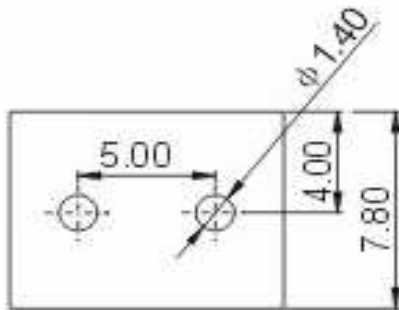

## Specification

### APPROVAL



### Electrical

Standard  
Rated voltage  
Rated current  
Wire range  
Withstanding voltage

UL	IEC
300V	450V
10A	18A
26-14 AWG	0.5-1.5mm <sup>2</sup>
AC2000V/1Min	

### Mechanical

Ambient temperature  
Strip length  
Screw, Torque

-40°C ~ +105°C  
6 ~ 7mm  
M2.5, 0.4Nm (3.5Lb-In.)

### Dimensions

Pitch  
Poles

5.00mm  
2P, 3P-24P

### Material

Housing  
Pin header  
Screw  
Wire guard

PA66 (UL94V-0)  
Brass, Tin plated  
steel, Cr<sup>3+</sup> Zn plated  
Stainless steel



### Certification



Wire Protector Terminal Block /  
Pitch 5.00mm

Part No.: A12L016

Customer:

DRW:	Bill	CHKD	Lord	MATL:	Jimmy	TOLERANCE	Sam	DATE	14.03.2009
APPD:	Louis			FINISH	Georg		Sheet No.		1 from 3

[www.edcon-components.com](http://www.edcon-components.com)

email: [info@edcon-components.com](mailto:info@edcon-components.com)

# EDCON-COMPONENTS



## Ordering Informations

Serie	-	No. of Pole	Body-Color	wire protector	Screw	-	Customer Request
A12L016	-	XX	XX	X	X	-	X

XX = total	WH - white	1 - with wire protector	A - Slotted screw (standard)
	GN - green	2 - without wire protector	B - Cross-slotted screw
	GR - gray		
	BL - blue		



PG - Phoenix Green
OR - orange
LG - light gray
BK - black



wire protector

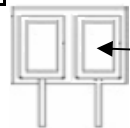

without wire protector



**Certification**



Wire Protector Terminal Block /  
Pitch 5.00mm

Part No.: A12L016

Customer:

DRW:	Bill	CHKD	Lord	MATL:	Jimmy	TOLERANCE	Sam	DATE	14.03.2009
APPD:	Louis			FINISH	Georg			Sheet No.	2 from 3

[www.edcon-components.com](http://www.edcon-components.com)

email: [info@edcon-components.com](mailto:info@edcon-components.com)



## Soldering - Profil

### Classification Reflow Profile (JEDEC J-STD-020C)

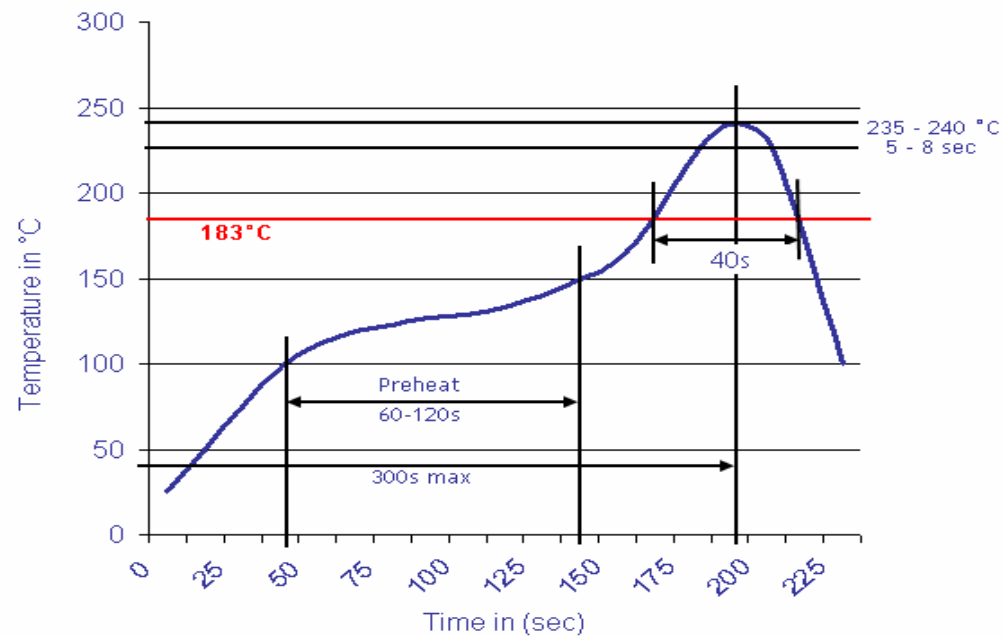

Wire Protector Terminal Block /  
Pitch 5.00mm

Part No.: A12L016

Customer:

DRW:	Bill	CHKD	Lord	MATL:	Jimmy	TOLERANCE	Sam	DATE	14.03.2009
APPD:	Louis			FINISH	Georg		Sheet No.	3 from 3	