

EDCON-COMPONENTS

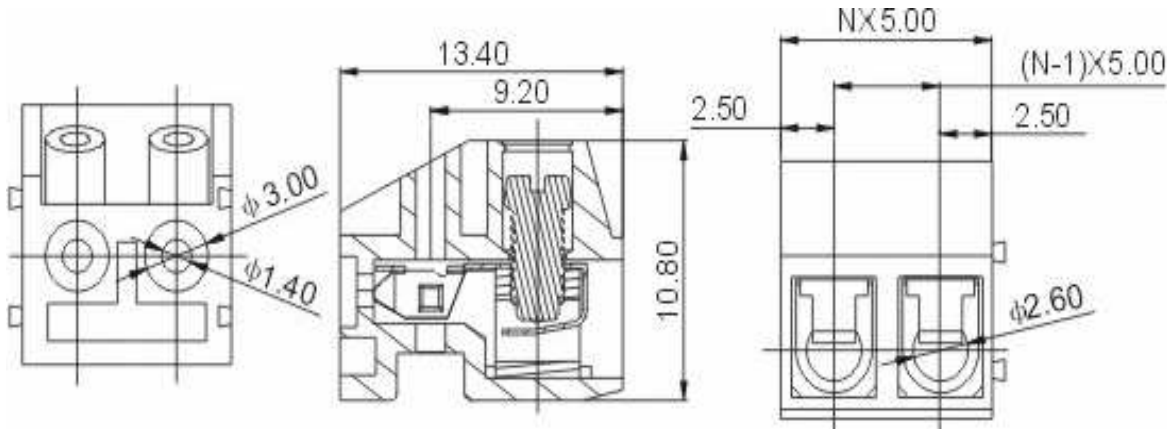

Drawing



P.C.B. Layout

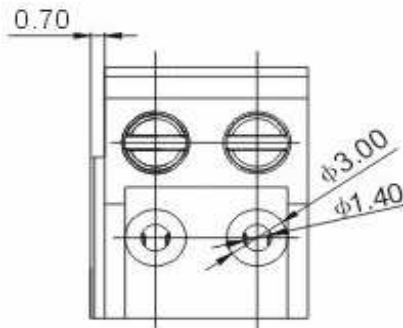

Specification

APPROVAL	cULus	CE
Electrical	UL	IEC
Standard	300V	250V
Rated voltage	10A	12A
Rated current	28-16 AWG	1.5mm ²
Wire range	AC2000V/1Min	
Withstanding voltage		
Mechanical		
Ambient temperature	-30°C ~ +120°C	
Strip length	5 ~ 6mm	
Screw, Torque	M2.5, 0.4Nm (3.5Lb-In.)	
Dimensions		
Pitch	5.00mm	
Poles	2P, 3P - 24P	
Material		
Housing	PBT (UL94V-0)	
Contact	Phosphor Bronze	
Screw	steel, Cr ³⁺ Zn plated	
Cage	Brass, Ni plated	



Certification



Wire Protector Terminal Block /
Pitch 5.00mm

Part No.: A12L013

Customer:

DRW:	Bill	CHKD	Lord	MATL:	Jimmy	TOLERANCE	Sam	DATE	14.03.2009
APPD:	Louis			FINISH	Georg		Sheet No.		1 from 3

www.edcon-components.com

email: info@edcon-components.com

EDCON-COMPONENTS



Ordering Informations

Serie	-	No. of Pole	Body-Color	wire protector	Screw	-	Customer Request
A12L013	-	XX	XX	X	X	-	X

XX = total	WH - white	1 - with wire protector	A - Slotted screw (standard)
	GN - green	2 - without wire protector	B - Cross-slotted screw
	GR - gray		
	BL - blue		



PG - Phoenix Green
OR - orange
LG - light gray
BK - black



wire protector

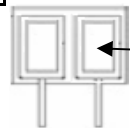

without wire protector



Certification



Wire Protector Terminal Block /
Pitch 5.00mm

Part No.: A12L013

Customer:

DRW:	Bill	CHKD	Lord	MATL:	Jimmy	TOLERANCE	Sam	DATE	14.03.2009
APPD:	Louis			FINISH	Georg		Sheet No.		2 from 3

www.edcon-components.com

email: info@edcon-components.com



Soldering - Profil

Classification Reflow Profile (JEDEC J-STD-020C)

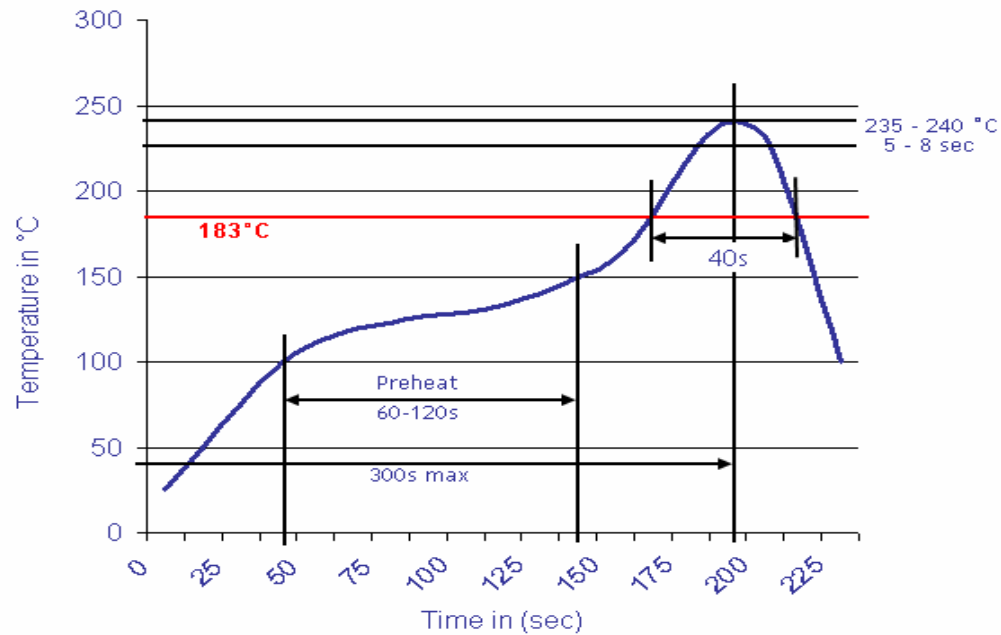

Wire Protector Terminal Block /
Pitch 5.00mm

Part No.: A12L013

Customer:

DRW:	Bill	CHKD	Lord	MATL:	Jimmy	TOLERANCE	Sam	DATE	14.03.2009
APPD:	Louis			FINISH	Georg			Sheet No.	3 from 3