

EDCON-COMPONENTS

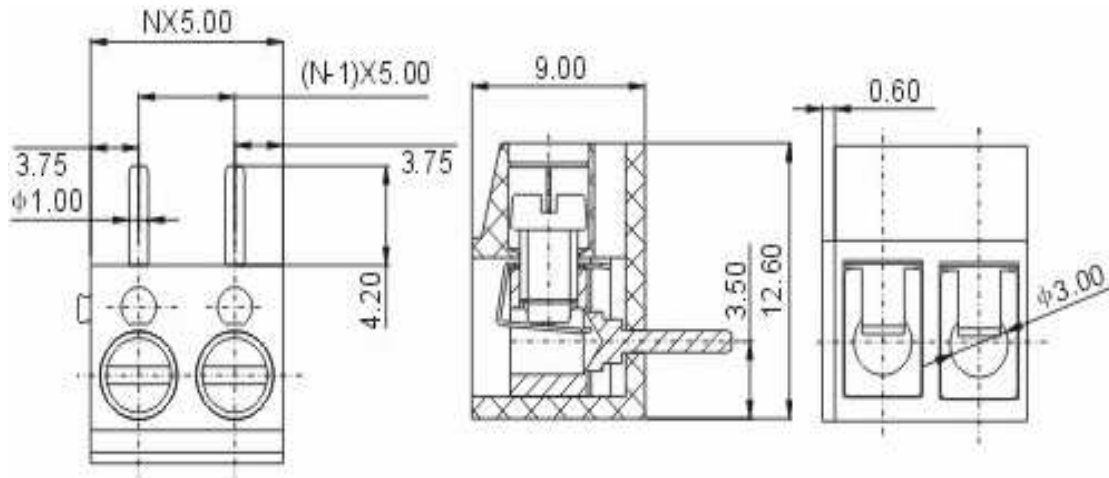

Drawing



P.C.B. Layout

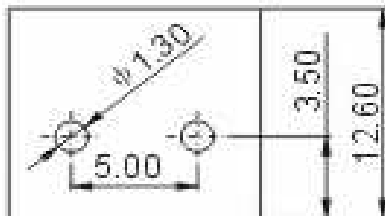

Specification

APPROVAL	UL	VDE
Electrical		
Standard	UL	IEC
Rated voltage	300V	250V
Rated current	10A	24A
Wire range	22-14 AWG	2.5mm ²
Withstanding voltage	AC2000V/1Min	
Mechanical		
Ambient temperature	-30°C ~ +120°C	
Strip length	5 ~ 6mm	
Screw, Torque	M3, 0.5Nm (4.4Lb-In.)	
Dimensions		
Pitch	5.00mm	
Poles	2P, 3P-24P	
Material		
Housing	PBT (UL94V-0)	
Pin header	Brass, Tin plated	
Screw	steel, Cr ³⁺ Zn plated	
Wire guard	Stainless steel	



Certification



Wire Protector Terminal Block /
Pitch 5.00mm

Part No.: A12L010

Customer:

DRW:	Bill	CHKD	Lord	MATL:	Jimmy	TOLERANCE	Sam	DATE	14.03.2009
APPD:	Louis			FINISH	Georg			Sheet No.	1 from 3

www.edcon-components.com

email: info@edcon-components.com

EDCON-COMPONENTS



Ordering Informations

Serie	-	No. of Pole	Body-Color	wire protector	Screw	-	Customer Request
A12L010	-	XX	XX	X	X	-	X

XX = total	WH - white	1 - with wire protector	A - Slotted screw (standard)
	GN - green	2 - without wire protector	B - Cross-slotted screw
	GR - gray		
	LG - light gray		



PG - Phoenix Green
OR - orange
BL - blue
BK - black



wire protector

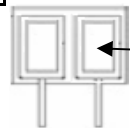

without wire protector



Certification



Wire Protector Terminal Block /
Pitch 5.00mm

Part No.: A12L010

Customer:

DRW:	Bill	CHKD	Lord	MATL:	Jimmy	TOLERANCE	Sam	DATE	14.03.2009
APPD:	Louis			FINISH	Georg		Sheet No.		2 from 3

www.edcon-components.com

email: info@edcon-components.com



Soldering - Profil

Classification Reflow Profile (JEDEC J-STD-020C)

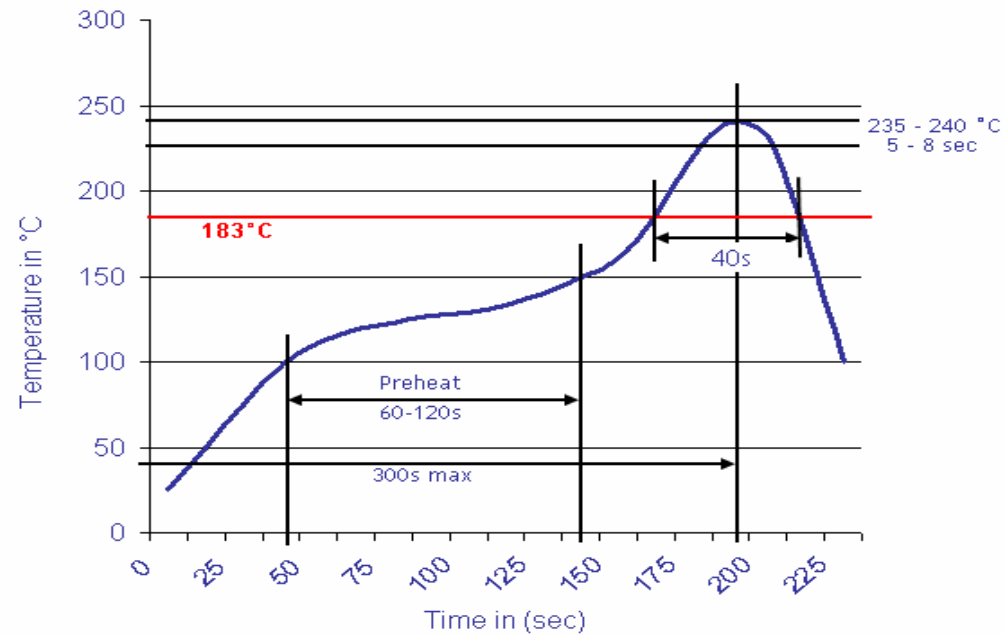

Wire Protector Terminal Block /
Pitch 5.00mm

Part No.: A12L010

Customer:

DRW:	Bill	CHKD	Lord	MATL:	Jimmy	TOLERANCE	Sam	DATE	14.03.2009
APPD:	Louis			FINISH	Georg		Sheet No.	3 from 3	