

EDCON-COMPONENTS

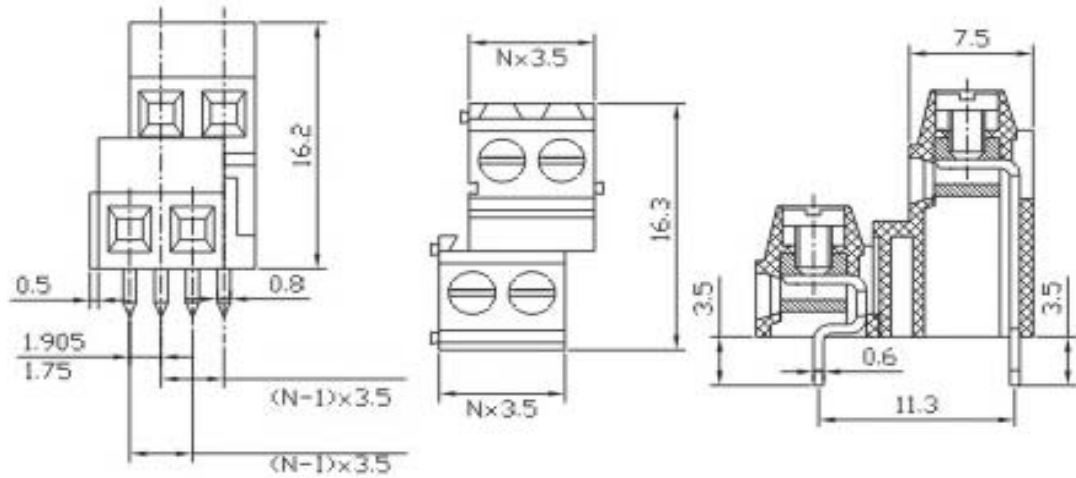

Drawing



P.C.B. Layout

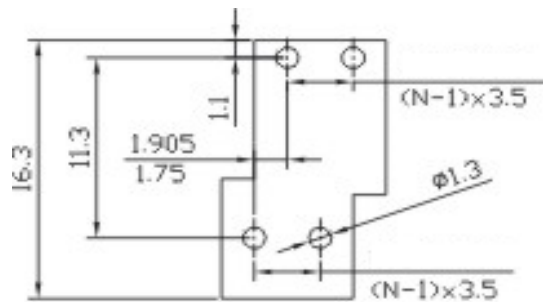

Specification

Electrical:

Rated voltage	300V
Rated current	10A
Wire range	26-16AWG / 1.5mm ²
Contact resistance	20m Ω
Withstanding voltage	AC 2000V/1Min
Insulation resistance	5000M Ω /DC1000V

Mechanical

Ambient temperature	-40°C ~ +105°C
Strip length	5 ~ 6mm
Torque	0.2Nm (1.7Lb.in)

Dimensions

Pitch	3.50mm
Poles	

Material

Housing	PA66, UL94V-0
Pin header	Brass, Tin-plated
Screw	M2, steel, Zinc-plated
Cage	Brass, Electroless nickel



Wire Protector Terminal Block /
Pitch 3.50mm

Part No.: A12G018

Customer:

DRW:	Bill	CHKD	Lord	MATL:	Jimmy	TOLERANCE	Sam	DATE	14.3.2009
APPD:	Louis			FINISH	Georg		Sheet No.		1 from 2

www.edcon-components.com

email: info@edcon-components.com

EDCON-COMPONENTS



Ordering Informations

Serie	-	No. of Pole	Body-Color	-	wire protector	-	Customer Request
A12G018	-	XX	XX	-	X	-	X

XX = total	WH - white
	GN - green
	GR - gray <i>(standard)</i>
	PG - Phoenix Green
	OR - orange <i>(standard)</i>
	BK - black
	BL - blue
	LG - light gray

1 - with wire protector
2 - without wire protector



Wire Protector Terminal Block /
Pitch 3.50mm

Part No.: A12G018

Customer:

DRW:	Bill	CHKD	Lord	MATL:	Jimmy	TOLERANCE	Sam	DATE	14.3.2009
APPD:	Louis			FINISH	Georg			Sheet No.	2 from 2

www.edcon-components.com

email: info@edcon-components.com