

# EDCON-COMPONENTS

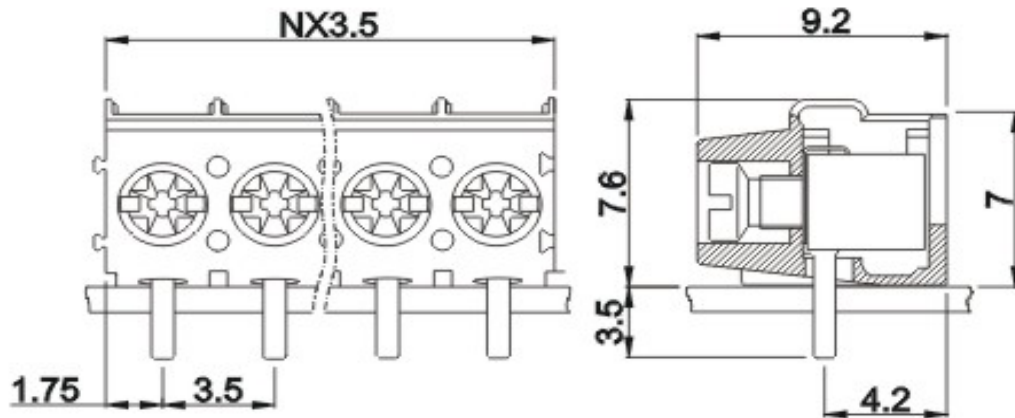

## Drawing



## P.C.B. Layout

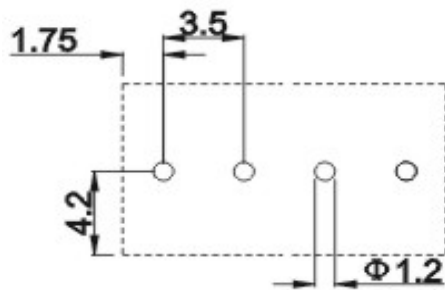

## Specification

### Electrical:

	UL	IEC
Standard	300V	200V
Rated voltage	10A	17.5A
Rated current	26-16AWG	1.5mm <sup>2</sup>
Wire range	AC1500V/1Min	
Withstanding voltage		

### Mechanical

Ambient temperature	-40°C ~ +105°C
Strip length	5mm
Torque	0.2Nm (1.7Lb-In.)

### Dimensions

Pitch	3.50mm
Poles	2P, 3P-24P

### Material

Housing	PA66, UL94V-0
Pin header	Brass, Tin plated
Screw	M2, steel, Cr <sup>3+</sup> Zn plated
Wire guard	Stainless steel



Wire Protector Terminal Block /  
Pitch 3.50mm

Part No.: A12G015

Customer:

DRW:	Bill	CHKD	Lord	MATL:	Jimmy	TOLERANCE	Sam	DATE	14.3.2009
APPD:	Louis			FINISH	Georg		Sheet No.	1 from 2	

[www.edcon-components.com](http://www.edcon-components.com)

email: [info@edcon-components.com](mailto:info@edcon-components.com)

Copyright by EDCON-COMPONENTS

# EDCON-COMPONENTS



## Ordering Informations

Serie	-	No. of Pole	Body-Color	-	wire protector	-	Customer Request
A12G015	-	XX	XX	-	X	-	X

XX = total	WH - white
	GN - green
	GR - gray (standard)
	PG - Phoenix Green
	OR - orange (standard)
	BK - black
	BL - blue
	LG - light gray

1 - with wire protector
2 - without wire protector



Wire Protector Terminal Block /  
Pitch 3.50mm

Part No.: A12G015

Customer:

DRW:	Bill	CHKD	Lord	MATL:	Jimmy	TOLERANCE	Sam	DATE	14.3.2009
APPD:	Louis			FINISH	Georg			Sheet No.	2 from 2

[www.edcon-components.com](http://www.edcon-components.com)

email: [info@edcon-components.com](mailto:info@edcon-components.com)